

23 February 2021

AEEC IPS – Telecon PP858 Document Status and Plan

MICHAEL OLIVE

Honeywell

PP858 Restructuring – Meeting 16 Discussion

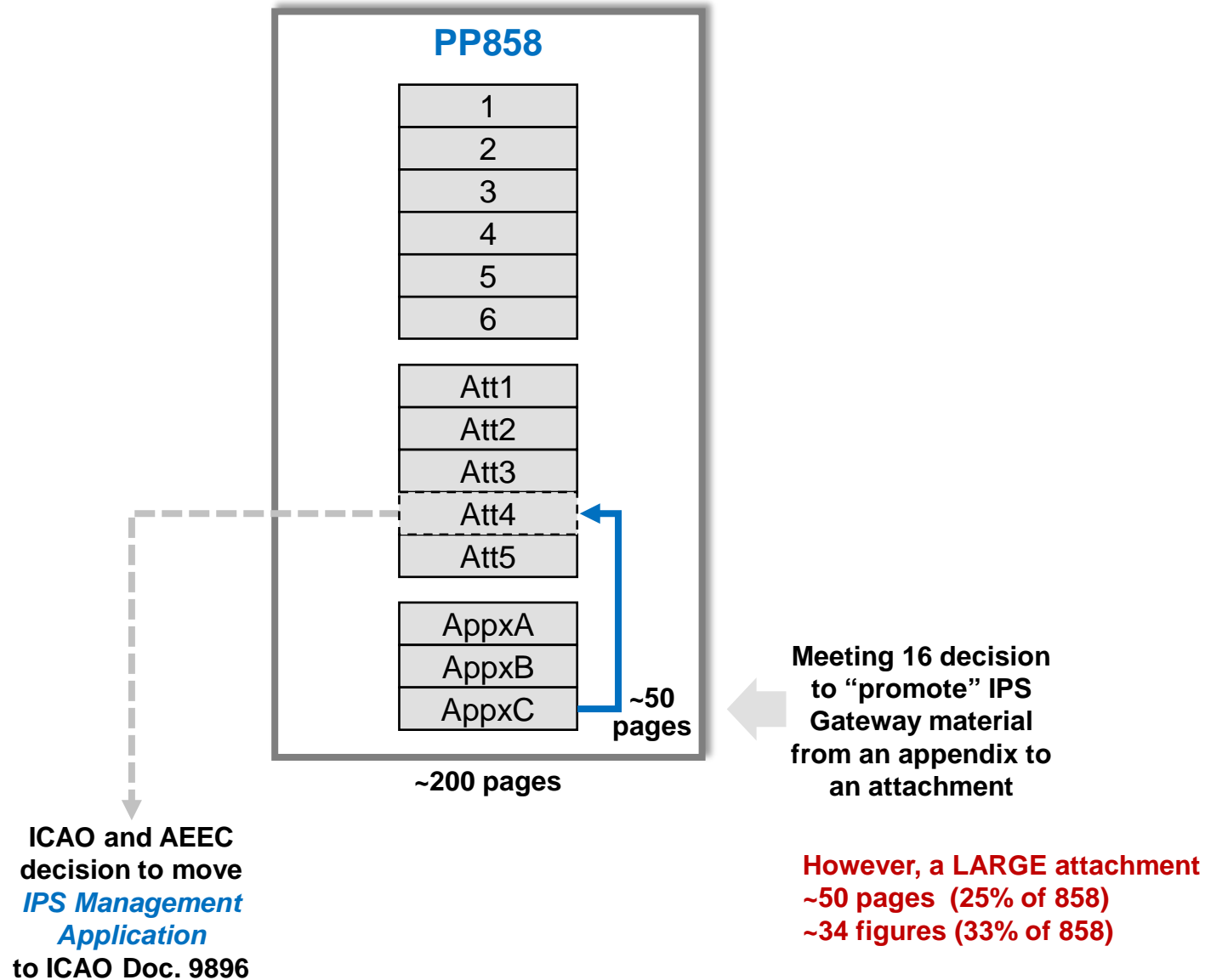

PP858 Restructuring - Post Meeting 16

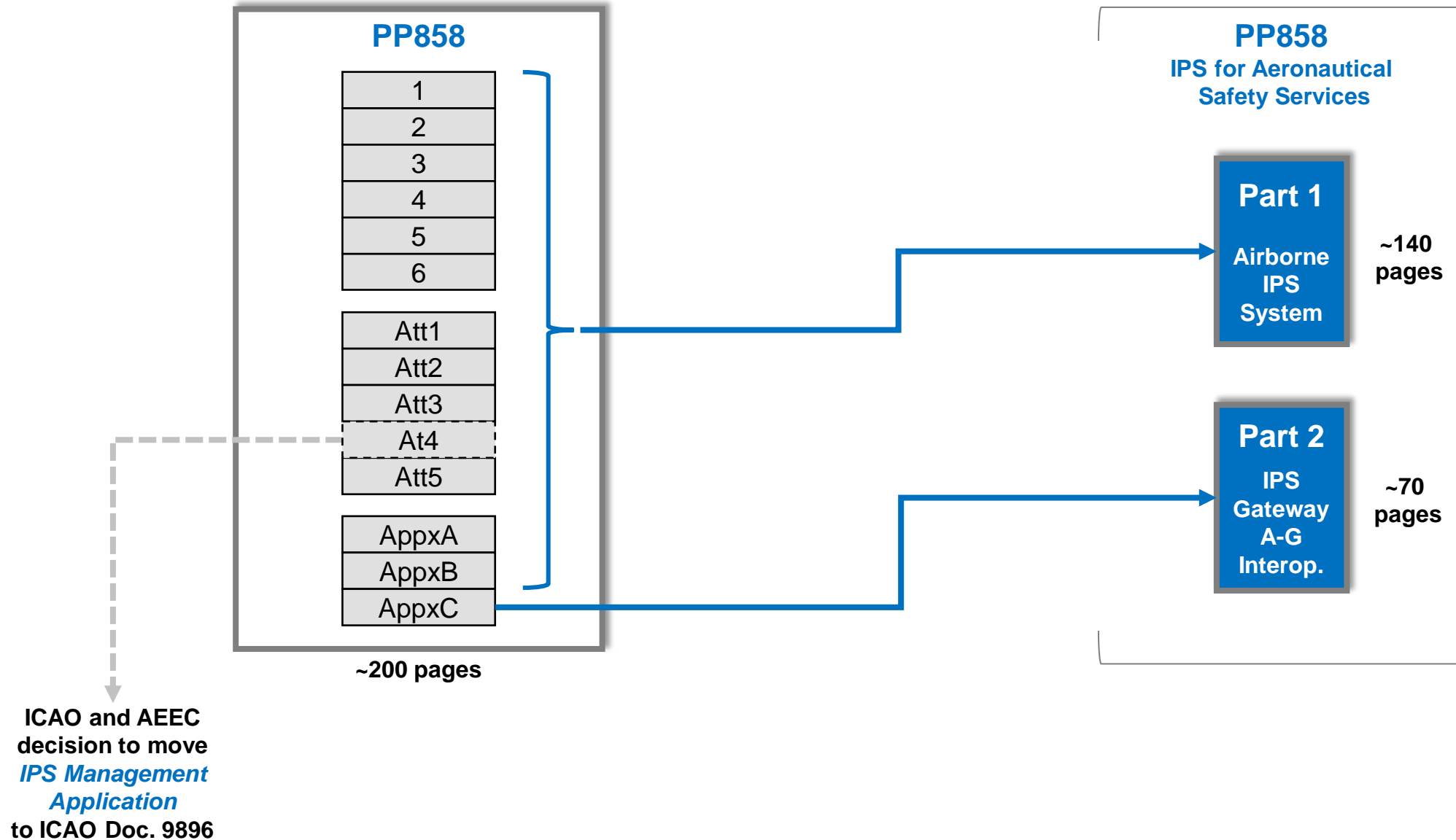

PP858 – Road to Adoption (Initial Document)

