

16-18 March 2021

# AEEC IPS – Meeting 17 PP858 Document Status and Plan

MICHAEL OLIVE

**Honeywell**

# PP858 Document Structure Evolution

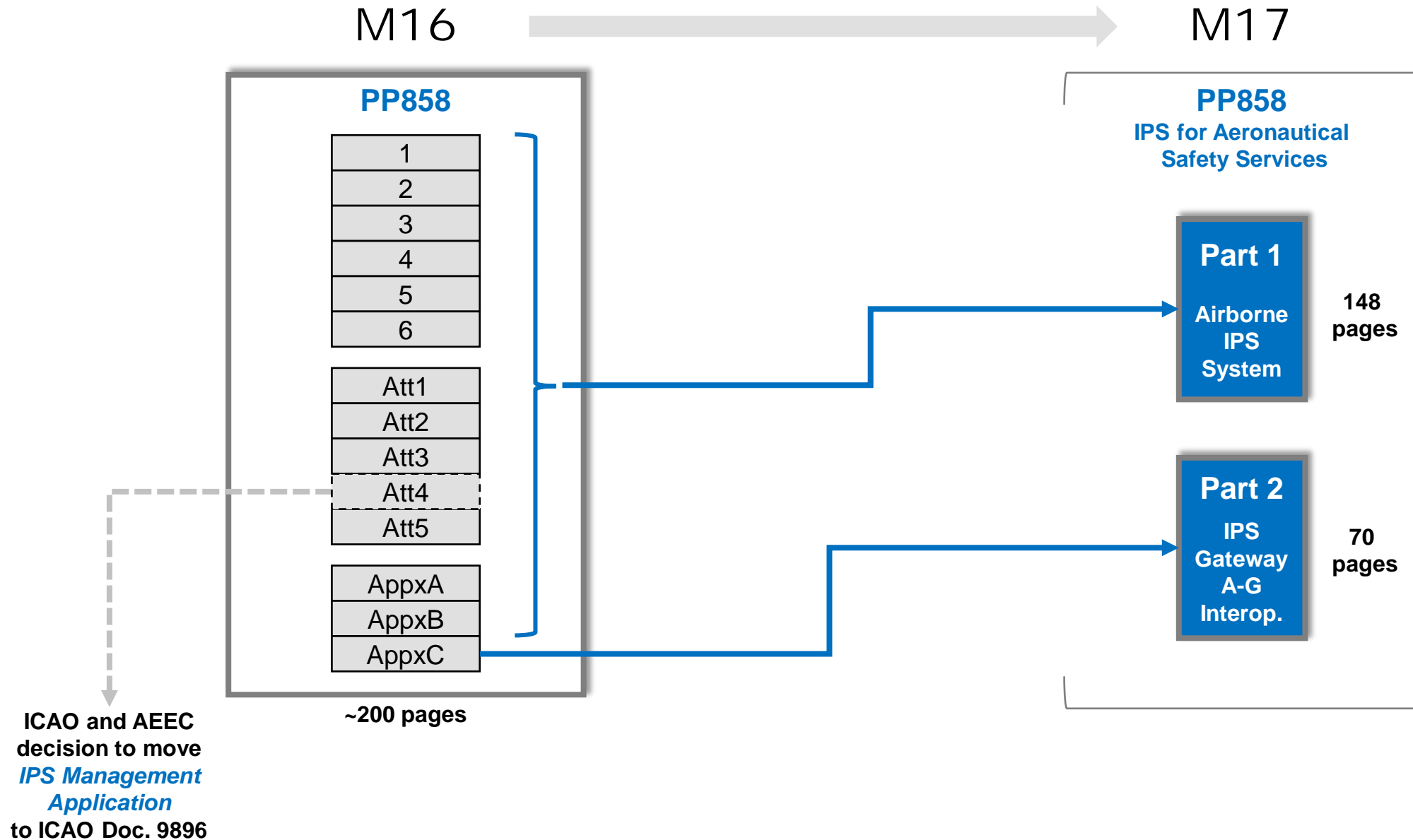

# ARINC Specification 858 Part 1 – Airborne IPS System

*Introductory and  
Context-setting  
Material*

1.0 Introduction

2.0 Overall IPS System Architecture

*Airborne IPS System Specification*

3.0 Airborne IPS System Architecture

4.0 Airborne IPS System Security

Attach 3 – ACARS to IPS DS Convergence Function

Attach 4 – IPS Security Event Log Format

*Airborne IPS System Guidance Material*

5.0 Implementation Options

6.0 Application Data Considerations

Appendix A – ATNPKT Examples

Appendix B – IPS Protocol Build-up

*Supporting  
Material*

Attach 1 – Acronyms

Attach 2 – Glossary

# ARINC Specification 858 Part 2 – IPS Gateway Air-Ground Interop.

*Introductory and  
Context-setting  
Material*

1.0 Introduction

2.0 Data Comm Environment Overview



*IPS Gateway*

3.0 IPS Gateway Function

4.0 IPS Gateway for ACARS

5.0 IPS Gateway for OSI

*Supporting  
Material*

Attach 1 – Acronyms

Attach 2 – Glossary

# PP858 Comment Status

|             | PP858 P1<br>d3-02 |         |            |        | PP858 P2<br>d1-02 |       |     |
|-------------|-------------------|---------|------------|--------|-------------------|-------|-----|
| Disposition | Boeing            | Collins | Frequentis | Thales | Collins           | TOTAL | %   |
| Accept      | 24                | 4       | 5          | 58     | 18                | 109   | 85% |
| Partial     | 2                 |         |            | 2      | 1                 | 5     |     |
| No Change   | 2                 |         | 1          | 1      | 1                 | 5     |     |
| Discuss     | 1                 | 3       | 5          | 8      | 4                 | 21    | 15% |
| TOTAL       | 29                | 7       | 11         | 69     | 24                | 140   |     |

# PP858 Comment Disposition Process

## 1. Responses to received comments coordinated with commenters, section authors, and/or SMEs

- For cases where the disposition was not straightforward

## 2. Initial disposition of comments provided to comment originators

- For review and feedback regarding how comments were handled

## 3. Changes integrated in the documents

- Editorial changes and suggestions for minor wording or figure changes → redlines accepted to reduce document clutter and streamline review during the meeting
- More substantive changes maintained as redline/strikeout for review during the meeting
- Comments marked as “Discuss” captured in the documents as comment balloons

## 4. Proposed actions during M17

- Review redlines; modify as required
- Disposition open comments

*Options* →

- **Resolve with real-time changes**
- **Agree that no changes are required**
- **Defer to Supplement 1**

# PP858 – Road to Adoption (Initial Document)

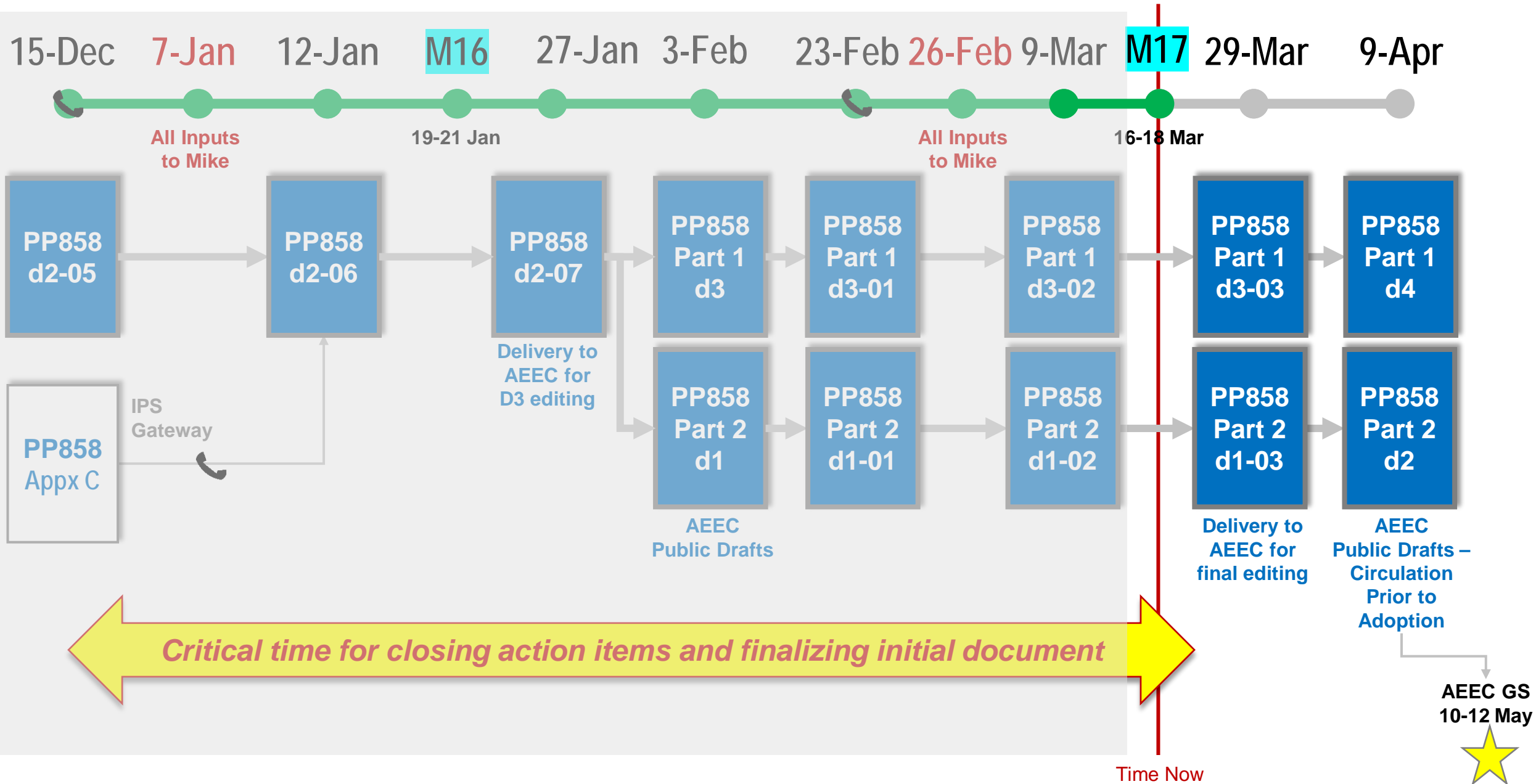

# ATN/IPS A/G Standardization Roadmap (rev. 2020-10-01b)

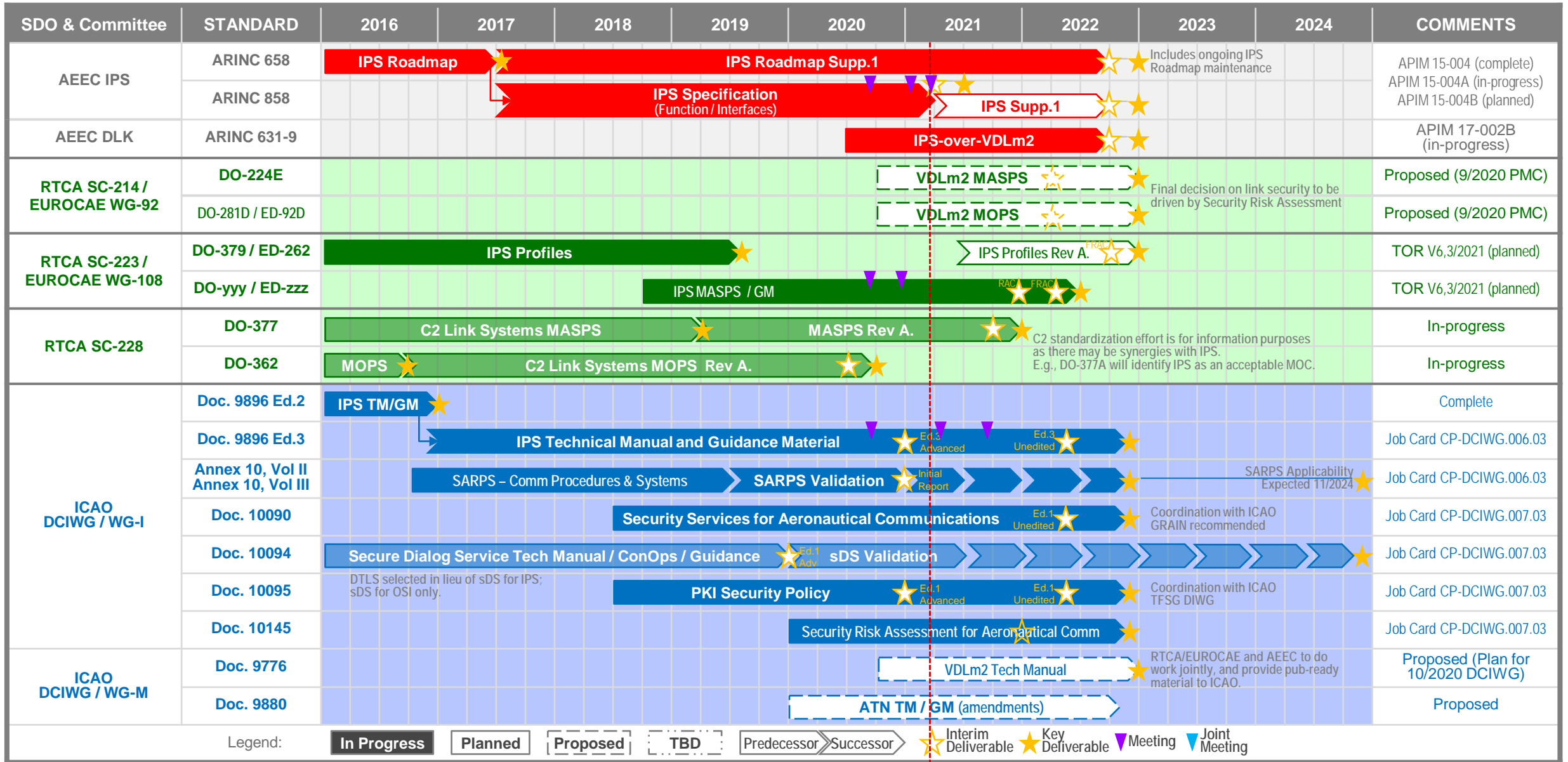

Legend:

In Progress

Planned

Proposed

TBD

Predecessor

Successor



Time Now



Post M17

# PP858 Comment Status - End of M17

| Disposition | PP858 P1<br>d3-02 |         |            |        | PP858 P2<br>d1-02 | TOTAL | %   |
|-------------|-------------------|---------|------------|--------|-------------------|-------|---|
|             | Boeing            | Collins | Frequentis | Thales | Collins           |       |   |
| Accept      | 21                | 4       | 9          | 64     | 19                | 117   | 95%  |
| Partial     | 5                 |         |            | 2      | 1                 | 8     |   |
| No Change   | 3                 |         | 1          | 3      | 1                 | 8     |   |
| Discuss     |                   |         |            |        | 1                 | 1     | 1%  |
| Defer (S1)  |                   | 3       | 1          |        | 2                 | 6     | 4%  |
| TOTAL       | 29                | 7       | 11         | 69     | 24                | 140   |   |

Captured in Supp1  
Action Item list

To be discussed/resolved during  
a Part 2 telecon on 24-March