

**STRAWMAN FOR ARINC PROJECT PAPER 680
TABLE OF CONTENTS**

Contents

1.0 INTRODUCTION	6
1.1 Purpose of this Document	6
1.2 Document Scope and Objectives	6
1.3 Document Organization	8
1.4 Requirements Documents	9
2.0 Autonomous Distress Tracking (ADT) Requirements Study.....	10
2.1 Requirements Study Introduction	10
2.1.2 Requirements Study Objectives.....	10
2.1.2 Requirements Study Structure.....	11
2.2 Autonomous Distress Tracking Requirements Overview	11
2.2.1 ICAO Requirements Flow Down.....	11
2.2.2 ICAO GADSS Related Requirements and Regulatory Status	13
2.2.3 Overview of Distress Tracking Requirements Sources	15
2.3 High Level Summary of Requirements Covered in Key Distress Requirements Sources.....	19
2.3.1 Annex 6 ADT Requirements	19
2.3.2 GADSS CONOPS ADT Requirements	20
2.3.3 ICAO ADT Guidance Material.....	22
2.3.4 ICAO Normal Tracking Requirements	23
2.3.5 EU Regulations for Aircraft Tracking and Aircraft in Distress Requirements.....	24
2.3.6 EUROCAE ED-237 MASPS for Criteria to Detect In-Flight Aircraft Distress Events to Trigger Transmission of Flight Information.....	26
2.4 Key Requirements Terms Discussion and Definitions.....	28
2.4.1 Key Terms Summary	28
2.4.2 Source documents and associated discussions	29
2.4.2.1 Autonomous Distress Tracking (ADT) and Autonomous Distress Tracking system	29
2.4.2.2 Autonomy	30
2.4.2.3 Distress.....	31
2.4.2.4 Nuisance alert	34
2.4.2.5 Resilience / Robustness to Failure	36
2.5 Integrated ADT Requirements for Architecture Study	39

**STRAWMAN FOR ARINC PROJECT PAPER 680
TABLE OF CONTENTS**

3.0 Autonomous Distress Tracking (ADT) Architecture Study	41
3.1 Architecture Study Introduction	41
3.1.1 Architecture Overview	41
3.1.2 An ADT Architectural Framework	42
3.2 Automatic Dependent Surveillance – Broadcast (ADS-B) Architecture Study	43
3.2.1 Description of Architecture	43
3.2.1.1 Operational Description – General Emergency Alerting	46
3.2.1.2 Operational Description – Potential Enhanced Alerting Features	47
3.2.2 ADS-B Architecture Mapped to the Architecture Frame Work	48
3.2.2.1 Key Architecture Assumptions and Dependencies	51
3.2.2.2 Key Airplane Infrastructure Support and Required Changes	51
3.2.2.3 Key Network Infrastructure Support and Required Changes	52
3.2.2.4 Key Ground Segment Support and Required Changes	52
3.2.3 Compliance with Requirements	52
3.2.4 Support for Related Services and Capabilities	53
3.3 ELT-DT Architecture Study	53
3.3.1 Description of ELT-DT Based Architecture	53
3.3.2 ELT-DT based Architecture Mapped to the Architecture Frame Work	61
3.3.3 Compliance with Requirements	65
3.3.4 Support for Related Services and Capabilities	65
3.4 Inmarsat Based SATCOM Architecture Study	66
3.4.1 Description of Architecture	66
3.4.2 Architecture Mapped to the Architecture Frame Work (action CA)	68
3.4.3 Compliance with Requirements ref appendix c (action CA)	69
3.4.4 Support for Related Services and Capabilities	69
3.5 ADT with Iridium Transceiver Architecture Study	71
3.5.1 Description of Architecture	71
3.5.2 Architecture Mapped to the Architecture Frame Work	75
3.5.3 Compliance with Requirements	77
3.5.4 Support for Related Services and Capabilities	77
3.6 Dissimilar Complementary Architecture Study	78
3.6.1 Description of Architecture (HG/VR)	78
3.6.2 Architecture Mapped to the Architecture Frame Work (BT)	84

**STRAWMAN FOR ARINC PROJECT PAPER 680
TABLE OF CONTENTS**

3.6.3 Compliance with Requirements (CA).....	84
3.6.4 Support for Related Services and Capabilities (VR / MB IOU)	84
3.7 Detection/Triggering Architecture.....	84
3.7.1 Description of Architecture.....	85
3.8 Airplane Integration Architecture.....	94
3.8.1 Requirements & Recommendations.....	94
3.8.1.1 ADT system equipment.....	97
3.8.1.2 Electrical interfaces and data bus.....	104
3.8.1.3 Electrical power	104
3.8.1.4 Installation aspects: Environmental Qualification	105
3.8.1.5 Zone installation aspects	105
3.8.1.6 Maintenance, system health monitoring and fault isolation	105
3.8.1.7 Particular risk analysis: fire	106
3.8.1.8 Software considerations	106
4.0 Summary and Conclusions.....	107
5.0 Acronyms	108
Appendix A ADT Requirements Summaries, Analyses and Discussion	110
A.1 ICAO Requirements.....	110
A.1.1 ICAO Annex 6	110
A.1.2 ICAO Annex 11	126
A.1.3 ICAO GADSS Concept of Operations (ConOps)	146
A.2 Regulatory Requirements	153
A.2.1 European Union (EU) Regulation	153
A.3 Requirements from Industry Documents, EUROCAE Requirements.....	157
Appendix B ADT Architectural Framework to Requirements Mapping.....	170

**STRAWMAN FOR ARINC PROJECT PAPER 680
TABLE OF CONTENTS**

Figure 1: Scope of ADT Report Requirements and Architecture Studies with Respect to ICAO GADSS Scope (ref GADSS CONOPS Ver 6).....	7
Figure 2: Functional Scope of ADT Report Requirements and Architecture Studies.....	8
Figure 3: Typical ICAO Requirements Flow-Down Process.....	12
Figure 4: Sources of Distress Tracking Requirements.....	16
Figure 5: Related or Relevant Requirement Sources.....	17
Figure 6: Relationships between Key ADT Requirements Sources.....	18
Figure 7: High Level Annex 6/GADSS ADT Related Requirements Timeline.....	19
Figure 8: Autonomous Distress Tracking Annex 6 Summary.....	20
Figure 9: Autonomous Distress Tracking GADSS CONOPS Summary (1 of 2).....	21
Figure 10: Autonomous Distress Tracking GADSS CONOPS Summary (2 of 2).....	22
Figure 11: Autonomous Distress Tracking ICAO Guidance Material Summary.....	23
Figure 12: Normal Tracking Requirement Sources Summary.....	24
Figure 13 GADSS CONOPS Version 6.0 Concept Scenarios (1 of 2).....	37
Figure 14 GADSS CONOPS Version 6.0 Concept Scenarios (2 of 2).....	38
Figure 15 SAI GAT Architecture Study Requirements Tables_REV_NEW.xls (embedded file).....	39
Figure 16: Illustration of Distress Tacking Data Flows to and from ICAO Data Repository.....	41
Figure 17 ADT Components and Functions for Study Architecture Framework.....	42
Figure 18 ADT Functional Block Definition for Study Architecture Framework.....	43
Figure 19 Space-Based ADS-B Network.....	44
Figure 20 ADS-B Architecture for Distress Tracking (Example).....	44
Figure 21 . Surveillance Status Field of Airborne Position Message.....	46
Figure 22 . Emergency State Field of the Emergency/Priority Status Message.....	47
Figure 23 . ADT Functional Block Diagram.....	49
Figure 24 . ADS-B Implementation Architecture.....	50
Figure 25 . ELT(DT) Performance Summary.....	58
Figure 26. Cospas-Sarsat Rescue System.....	59
Figure 27. GADSS Conops 6.0 ELT(DT) Swim Lane.....	60
Figure 28. ELT-DT Mapped to ADT Functional Blocks.....	61
Figure 29: Overall ADT architecture as published within ICAO Doc 10054.....	67
Figure 30: Inmarsat GADSS implementation.....	68
Figure 31: ADT SATCOM Iridium Architecture Option 1 (External Trigger Source).....	72
Figure 32: ADT SATCOM Iridium Architecture Option 2 (Internal Trigger Function).....	73
Figure 33: ADT SATCOM Iridium Architecture Option 3 (External and Internal Trigger Functions).....	74
Figure 34: ADT SATCOM Iridium Architecture Option 4 (External and Internal Trigger Functions, Internal Iridium Transceiver Unit).....	75
Figure 35: ADT functional architecture.....	86
Figure 36: The scope of work of this document: the Distress/Triggering architecture and its interfaces.....	87
Figure 37: Further detailing of the Distress/Triggering architecture and its interfaces; and the minimization of nuisance triggers by inhibition of the logic in certain flight phases.....	88
Figure 38: Distress Event Detection architecture.....	89
Figure 39: Triggering Criteria Logic architecture.....	90
Figure 40: ADT system functional architecture.....	96

**STRAWMAN FOR ARINC PROJECT PAPER 680
TABLE OF CONTENTS**

Figure 41: Possible ADT system architecture. A new computer unit/computer module is inserted to compute the distress event / triggering criteria logic.	99
Figure 42: Possible ADT system architecture. Note that this figure differs from Figure 2, in the aspect that the switch and the display blocks are directly connected to the transmission system.	100
Figure 43: Possible ADT system architecture.	101
Figure 44: Possible ADT system architecture. In this scheme, the distress event detection / triggering criteria logic computing is performed on the ground.	102
Figure 45: Possible ADT system architecture. Note that this figure only differs from Figure 5, in the aspect that both the airborne and ground transmission and reception systems are integrated.	103
Figure 46 Study Requirements Mapped to Study Architecture Framework	170
Figure 47 Study Architecture Framework Functions Mapped to Implementation Architectures.	170
Figure 48 Study Architecture Framework Applied to SATCOM System.	171
Figure 49 Study Architecture Framework Applied to ELT-DT Based System	171
Figure 50 Study Architecture Framework Applied to Ground Processing Functions	172

List of Tables

Table 1: GADSS Related ICAO Annex 6 Requirements Summary.	13
Table 2: Normal Tracking Regional and National Regulator Status.	14
Table 3: Distress Tracking Regional and National Regulator Status.	15
Table 4: Overview of the most common dissimilar complimentary architectures.	83
Table 5: Annex 6 AIRCRAFT TRACKING Requirements.	110
Table 6: Annex 6 LOCATION OF AN AEROPLANE IN DISTRESS Requirements.	116
Table 7: Annex 11 Requirements and Comparison with GADSS CONOPS.	126
Table 8: GADSS CONOPS Requirements Summary.	146
Table 9 Analysis/Discussion of EU 2015/2338.	154
Table 10 Analysis/Discussion of ED-237.	157

STRAWMAN FOR ARINC PROJECT PAPER 680

1.0 INTRODUCTION

1.1 Purpose of this Document

This report documents the requirements and architectural options to support an Autonomous Distress Tracking (ADT) System to meet requirements for locating aircraft in distress and after an accident that are being levied by the International Civil Aviation Organization (ICAO) and individual Civil Aviation Authorities (CAAs).

Commented [SG1]:

Commented [SG2]:

Commented [SG3]:

COMMENTARY

The difficulty in locating the crash sites of several commercial aircraft losses over the last decade has prompted significant international effort to provide means for a global aircraft tracking capability. Since 2015, ICAO has worked to amend ICAO Annex 6 standards to include requirements for tracking commercial planes during all flight phases, including functionality for autonomous identification and reporting of distress situations (Autonomous Distress Tracking). In addition, The European Commission has published Commission Regulation (EU) 2015/2338 with similar, but in some cases, differing, requirements.

Commented [SG4]:

Commented [SG5]:

Commented [AC06]: Generalize rather than specific accidents.

The ICAO and CAA requirements cover both aircraft-level and on-ground systems. This report also documents additional system-level requirements derived from the evaluation of ICAO, CAA and relevant industry documents and potential ADT system architectures.

Commented [SG7]: A simple sentence to clarify the parenthetical phrase.

Commented [SG8]: Proposal to bring in line with my previous comment.

Multiple potential ADT architectures are described, in the context of a common architectural framework and the requirements identified in the requirements study, covering the primary systems that have been proposed as candidates for providing these capabilities. Implementation recommendations from an airplane level perspective are also discussed.

1.2 Document Scope and Objectives

The ICAO Annex 6 requirements and the associated ICAO Global Aeronautical Distress and Safety System (GADSS) Concept of Operations (CONOPS) describe a package of capabilities to address enhancing the finding of downed aircraft or of an aircraft in distress. These capabilities cover aircraft tracking during routine operations (normal tracking), distress tracking, improved aircraft craft site localization (longer operational life underwater beacons and low frequency underwater beacons) and the timely recovery of flight data.

The scope of this document is documenting the system-level requirements for an Autonomous Distress Tracking (ADT) System and providing a survey of potential architectures to support these requirements. The broader ICAO Annex 6 and GADSS CONOPS scope and the focused scope of this study are shown in Figure 1.

STRAWMAN FOR ARINC PROJECT PAPER 680

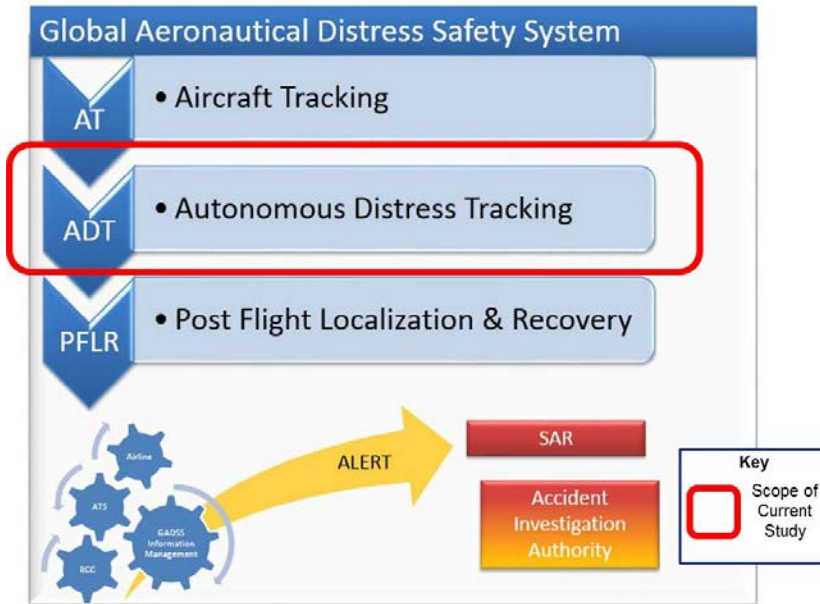

Figure 1: Scope of ADT Report Requirements and Architecture Studies with Respect to ICAO GADSS Scope (ref GADSS CONOPS Ver 6)

The primary purpose of the requirements survey and development and the architectural studies in this report are to provide a basis for developing standards to support effective implementation of the ICAO ADT recommendations in terms of understanding key requirements, functions and interfaces. To meet this purpose the objectives of this ARINC report are:

1. Capture all currently documented ICAO and regulatory system-level requirements for an ADT system (as a "snapshot" as of the release of this report).
2. Integrate these and derive a requirements set to use in evaluating a range of potential ADT architectures.

Note: *The derived requirements set are a means to provide a common baseline for developing and evaluating architecture and interfaces and are thus are a means to an end (that of developing effective ADT standards) and not themselves an end result.*

3. Perform a study of applicable ADT architectures to support the following characteristics or standards development work.

A secondary purpose for this report is to support industry's understanding of the requirements and options for ADTs.

Within the autonomous distress tracking scope of the report as described above, there is a further focusing of the document's scope to the distress tracking functionality on the aircraft, including the aircraft state monitoring, the distress and event detection and triggering criteria

STRAWMAN FOR ARINC PROJECT PAPER 680

functionality and the distress report transmission systems as illustrated in Figure 2. This figure also shows the scope of assumptions on the behavior/role of the flight crew for this report, non-adversarial but not necessarily cooperative (e.g. fully engaged in attempting to recover the aircraft)..

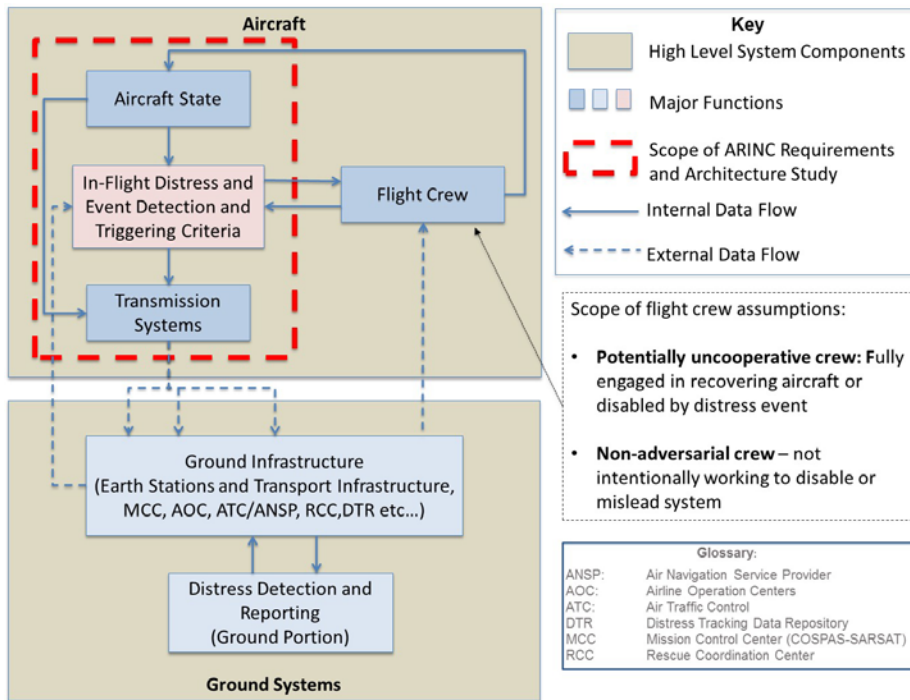

Figure 2: Functional Scope of ADT Report Requirements and Architecture Studies

1.3 Document Organization

Section (chapter) 2 of this report contains the requirements study including:

1. Requirements study scope and objectives (section 2.1.1)
2. An overview of the major autonomous distress tracking requirements sources (section 2.2)
3. An overview of the requirements in the major autonomous distress tracking requirements sources (section 2.3)
4. A cross-source discussion of key autonomous distress tracking requirements (section 2.4)
5. The derived requirements set developed to support the architecture study (section 2.5.)

STRAWMAN FOR ARINC PROJECT PAPER 680

6. Appendix A provides tables capturing requirements analysis details with by requirement cross references and discussions developed during the analysis process

Section 3 of this report provides an overview of architectures which could be used to meet some or all of the requirements of an ADT system as well as a discussion of additional issues which should be considered when developing an ADT system.

The architectures analyzed in section 3 include:

- 1.) The primary implementation options identified as potential ADT candidates:
 - Section 3.2: Automatic Dependent Surveillance – Broadcast (ADS-B) based systems
 - Section 3.3 Emergency Locator Transmitter – Distress Tracker (ELT-DT) based systems.
 - Section 3.4 and 3.5 Satellite Communications (SATCOM) based systems, INMARSAT and Iridium based systems respectively.
- 2.) Section 3.6 on Complimentary-Dissimilar Architectures - A survey of potential combinations of existing or proposed architectures that could support ADT requirements.
- 3.) Section 3.7 describes a notional or target architecture for the ADT detection and trigger capabilities.
- 4.) Section 3.8 discusses airplane implementation aspects of the ADT architecture and provides some recommendations to support effective integration onto an aircraft.

Section 4 provides a summary of findings and conclusions including identifying areas of commonality amongst the various architectures evaluated and proposals for areas of standardization.

Appendix B provides a mapping of the integrated requirements set in section 2 to the architecture framework described in section 3, as well as several examples of the architectural framework applied to different architectures.

1.4 Requirements Documents

These documents provide source requirements for the ADT system or relevant related requirements:

International Civil Aviation Organization (ICAO)

1. Annex 6 to the Convention on International Civil Aviation, Part 1, Tenth Edition (July 2016)
2. Annex 11, 14th Edition (2016), SARPS for Distress Reporting
3. Global Aeronautical Distress and Safety System (GADSS) CONOPS Ver 6.0 (7 June 2017)
4. Doc 10054 Manual on Location of Aircraft in Distress and Flight Recorder Data Recovery (draft)
5. White Paper, Distress Tracking Data Repository (DTR), Version 1 (12 January 2018)
6. Circular 347, Aircraft Tracking, Implementation Guidelines For Operators and Civil Aviation Authorities, 2017 Edition, (January 1, 2017) Normal Tracking Implementation Guidelines.

STRAWMAN FOR ARINC PROJECT PAPER 680

European Union (EU)

7. COMMISSION REGULATION (EU) 965/2012, 5 October 2012. Technical requirements and administrative procedures related to air operations
8. COMMISSION REGULATION (EU) 2015/2338 11 December 2015. Amends 965/2012 to add CAT.GEN.MPA.210 Location of an Aircraft in Distress

European Aviation Safety Agency (EASA)

9. Executive Director (ED) Decision 2016-012 Acceptable Means of Compliance (AMC) and Guidance Material (GM) to implementing rules on flight recorders, underwater locating devices and aircraft tracking systems (second set)) (12 September 2016)

European Organisation for Civil Aviation Equipment (EUROCAE)

10. ED-237 (February 2016) Minimum Aviation System Performance Specification (MASPS) for Criteria to Detect In-Flight Aircraft Distress Events to Trigger Transmission of Flight Information.

European Organisation for Civil Aviation Equipment (EUROCAE), RTCA, Inc

11. ED-62B / DO-204B (draft) Minimum Operational Performance Specification (MOPS) for Aircraft Emergency Locator Transmitter

United States Federal Aviation Administration (FAA)

12. Special Conditions (SC) and Means of Compliance (MoC) for Non Rechargeable Lithium Battery (NRLB) Installation (April 2017 Applicability)
13. Airframe level safety/certification requirements, see for example: Example of FAA Special Conditions: <<https://www.gpo.gov/fdsys/pkg/FR-2016-04-22/pdf/2016-09311.pdf>>
14. TSO-142B NON-RECHARGEABLE LITHIUM CELLS and BATTERIES (26 March 2018)
<[http://rgl.faa.gov/Regulatory_and_Guidance_Library/rgTSO.nsf/0/0300ac09856ec79a8625825d00523aa0/\\$FILE/TSO-C142b.pdf](http://rgl.faa.gov/Regulatory_and_Guidance_Library/rgTSO.nsf/0/0300ac09856ec79a8625825d00523aa0/$FILE/TSO-C142b.pdf)>
15. TSO-179B RECHARGEABLE LITHIUM CELLS and BATTERIES (26 March 2018)
<[http://rgl.faa.gov/Regulatory_and_Guidance_Library/rgTSO.nsf/067ff4fd73b2def078625825f00716b87/\\$FILE/TSO_C179b.pdf](http://rgl.faa.gov/Regulatory_and_Guidance_Library/rgTSO.nsf/067ff4fd73b2def078625825f00716b87/$FILE/TSO_C179b.pdf)>

RTCA Inc

16. RTCA/DO-227A, Minimum Operational Performance Standards for Non-Rechargeable Lithium Batteries (September 21, 2017)
17. RTCA DO-311A Minimum Operational Performance Standards for Rechargeable Lithium Batteries and Battery Systems (December 19, 2017)

2.0 Autonomous Distress Tracking (ADT) Requirements Study

2.1 Requirements Study Introduction

2.1.2 Requirements Study Objectives

As discussed in the document introduction, the primary purpose of the requirements survey and the derived development provided in this section is to provide a basis for developing

STRAWMAN FOR ARINC PROJECT PAPER 680

standards to support effective implementation of the ICAO ADT recommendations in terms of understanding key requirements, functions and interfaces. To meet this purpose the objectives of this section of the report are:

1. Capture all currently documented ICAO and regulatory system-level requirements for an ADT system (as a “snapshot” as of the release of this report).
2. Integrate these and derive a requirements set to use in evaluating a range of potential ADT architectures.

Note: *The derived requirements set are a means to provide a common baseline for developing and evaluating architecture and interfaces and are thus are a means to an end (that of developing effective ADT standards) and not themselves an end result.*

2.1.2 Requirements Study Structure

The major sections of Section (chapter) 2 of are as follows:

1. An overview of the major autonomous distress tracking requirements sources, including discussion of requirements flow-downs and organizational responsibilities, the major requirements sources from each organization, the relationships between the requirements sources and the timing for requirements releases (section 2.2)
2. An overview of the lower level requirements in the major autonomous distress tracking requirements sources with a particular focus on the ICAO requirements, including those for the related area of normal tracking (section 2.3)
3. A cross-source discussion of key autonomous distress tracking requirements (section 2.4)
4. The derived requirements set developed to support the architecture study (section 2.5.)
5. Appendix A provides tables capturing requirements analysis details with by requirement cross references and discussions developed during the analysis process

2.2 Autonomous Distress Tracking Requirements Overview

2.2.1 ICAO Requirements Flow Down

A “typical” requirements development and implementation flow is shown in Figure 3.

STRAWMAN FOR ARINC PROJECT PAPER 680

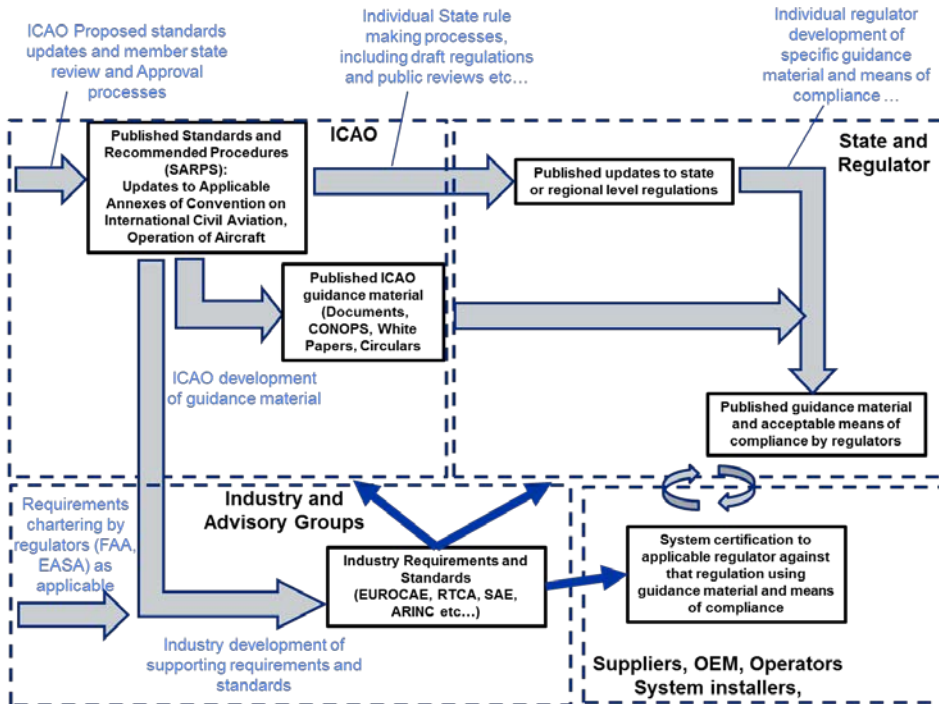

Figure 3: Typical ICAO Requirements Flow-Down Process

The flow starts with a precipitating set of events or some identified need for new or improved capabilities, this would on the left hand side of Figure 3. These would typically be addressed by ICAO led multinational/cross-industry teams developing updates to the ICAO civil aviation Standards and Recommended Procedures (SARPS).

During this same timeframe, major regulators (e.g. ESAS and the FAA) may charter industry groups under EUROCAE or RTCA to develop detailed functional and performance requirements to support the new capability.

ICAO teams would also be developing further guidance material to support the SARPS.

Both the ICAO SARPS and the guidance material would be then be picked up for evaluation and potential implementation by national and regional airspace law makers and regulators. These law makers and regulators would implement the ICAO SARPS according to their regional or national needs, in some cases picking up the ICAO SARPS and guidance material recommendations verbatim but in other cases adding or modifying as required to meet their needs. It is not uncommon for a larger regulator, such as the FAA, to forego implementing some ICAO SARPS based on the local capabilities and needs, but in general, most regulators will implement the SARPS in a manner consistent with ICAO recommendations.

STRAWMAN FOR ARINC PROJECT PAPER 680

Once the regulatory requirements are available, or even earlier if the demand is sufficient and the expected requirements fairly straightforward and well defined, industry will start to develop systems to provide the required capabilities.

2.2.2 ICAO GADSS Related Requirements and Regulatory Status

ICAO Annex 6 to the Convention on International Civil Aviation, Operation of Aircraft, Part 1, International Commercial Air Transport — Aeroplanes, Tenth Edition published in July 2016 provides the SARPS for autonomous distress tracking. Amendment 42, published 10 July 2017, provides an update with the current normal tracking SARPS.

Table 1 summarizes the major capabilities called out by ICAO Annex 6 that provide the basis for the Aeronautical Distress and Safety System. Of these, in addition to autonomous distress tracking, this report will touch on some aspects of the normal tracking requirements due to their potentially close relationship in terms of operator capabilities to distress tracking operator capabilities. The timely recovery of flight data requirements will be addressed in a follow-on report. The LF-ULD requirements are localization focused and are not addressed further in this report.

Table 1: GADSS Related ICAO Annex 6 Requirements Summary.

GADSS Function	ICAO Applicability	Requirements	Notes
Low Frequency Underwater Locator Device (LF-ULD) (Introduced in previous amendment)	Jan 2018 (forward fit and retrofit)	Attaches to airframe, 8.8 kHz Acoustic Beacon with 12 NM propagation range	EASA 2019 mandate has largest airline impact. For most regulators there is no alternate means of compliance
Normal Tracking	Nov 2018 (forward fit and retrofit)	Uses current connectivity Position reports every 15 minutes Optional abnormal event tracking capability	
Autonomous Distress Tracking (ADT)	2021 (forward fit)	Position reports once per minute, within 6NM of crash location, independent of aircraft power, not isolatable, can be remotely activated.	Multiple capabilities potentially support
Timely Recovery of Flight Data	2021 (new type designs)	In work performance based requirements, TBD duration,	Primary options are flight data streaming

STRAWMAN FOR ARINC PROJECT PAPER 680

GADSS Function	ICAO Applicability	Requirements	Notes
		assurance, TBD set of FDR and CVR data	or deployable flight data recorder

Table 2 summarizes the normal tracking regulation status. With the ICAO implementation date in 2018, a significant group of regulators is moving forward with regional and national regulations for this capability, a key component of the GADSS concept of operations and a significant step, especially in terms of operator flight following capabilities towards the flight tracking capability required for distress tracking.

Table 2: Normal Tracking Regional and National Regulator Status.

Organization/ Regulator	Normal Tracking Requirements			
	Applicability Date	Forward Fit Required?	Retrofit Required?	Type of Mandate
ICAO	Nov 8, 2018	✓	✓	Requirement for all aircraft flying in oceanic airspace to be tracked automatically with minimum 15 minute interval
EASA	2019	✓	✓	Requirement for all aircraft to be tracked from takeoff to landing automatically with minimum 15 minute interval – in 2021 minimum 3 minute interval if no ADT capability
CAAC	Dec 1, 2016	✓	✓	Advisory Circular consistent with ICAO Circular
India	May 5, 2014 (manual acceptable) 2016 (automatic required)	?	?	AIR SAFETY CIRCULAR 04 OF 2014 Operators should use all suitable means to track all its aircraft engaged in the carriage of passengers/cargo from departure (Chocks-off) to arrival (Chocks-on).
Malaysia	Mar 8, 2015	✓	✓	Malaysian Airlines required to implement 15 minute tracking

STRAWMAN FOR ARINC PROJECT PAPER 680

Organization/ Regulator	Normal Tracking Requirements			
	Applicability Date	Forward Fit Required?	Retrofit Required?	Type of Mandate
CAAS	July 1, 2016 (manual acceptable)			From July 1, 2016 airlines required to track aircraft manually or automatically.
	Nov 8, 2018 (automatic required)	✓	✓	From Nov 8, 2018, only automatic tracking will be permitted.

Table 3 summarizes the current state of autonomous distress tracking regulator status. At this point, with the ICAO applicability date in 2021, only the European Union (EU) has applicable regulations in place. It is expected that as the ICAO 2021 implementation date draws closer that many additional states and regions will implement autonomous distress tracking regulations as well. In the case of the LF-ULD, the year prior to the ICAO implementation date saw a steady stream of regulators releasing rules requiring LF-ULD implementation per the ICAO SARPs.

Table 3: Distress Tracking Regional and National Regulator Status.

Organization/ Regulator	Autonomous Distress Tracking Requirements			
	Applicability Date	Forward Fit Required?	Retrofit Required?	Type of Mandate
ICAO	Jan. 2021	✓		Means to track aircraft position to end-of-flight
EU/EASA	Jan. 2021	✓		(within 6 NM)

2.2.3 Overview of Distress Tracking Requirements Sources

As shown in Figure 4, the major sources of distress tracking requirements are the ICAO annex 6 SARPs, the Annex 11 SARPs on distress reporting. These ICAO SARPs have a growing body of supporting guidance material, including the GADSS CONOPS, the mature draft document 10054, manual on the Location of Aircraft in Distress and Flight Data recovery, and the white paper on the implementation of a distress tracking data repository (DTR).

STRAWMAN FOR ARINC PROJECT PAPER 680

A major supporting industry document is the EUROCAE ED-237, a Minimum Aviation System Performance Specification (MASPS) on criteria to detect distress events to be used in triggering the transmission of distress tracking or flight data recovery information.

The EU regulation directly addressing distress tracking is CR 2015/2338 CAT GEN MPA.210, the associated executive decision, ED 2016-012, providing acceptable means of compliance and guidance material explicitly does not address distress tracking, deferring the development and release of this material to follow the release of the ICAO document 10054.

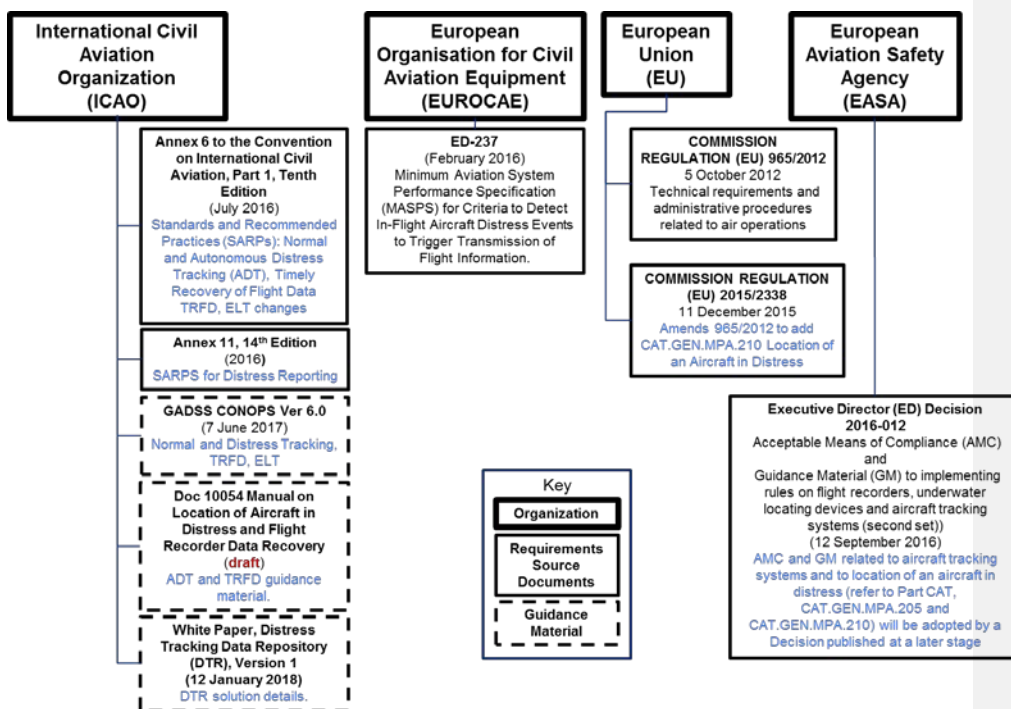

Figure 4: Sources of Distress Tracking Requirements

In addition to the primary sources of requirement for distress tracking, there are number of secondary, supporting or related sources of requirements to be aware of or taken into consideration, these are shown in Figure 5.

A major industry development that has occurred in parallel to the requirements and capabilities for distress tracking being developed, is the way that Lithium battery equipped systems are specified and certified. With the new requirements that have emerged from the increased understanding of the risks of high power density Lithium batteries that have emerged from multiple major failures of Lithium battery equipped systems in recent years, new requirements are in place that probably effectively

STRAWMAN FOR ARINC PROJECT PAPER 680

preclude the certification of systems that several years ago would have been acceptable. With Lithium batteries as a significant means to achieving resilience to power system failures in distress conditions, these are new requirements, shown under the FAA and RTCA in Figure 5 are potentially critical path requirements for ADT systems.

A major potential ADT compliant system capability is the in development Distress Tracking Emergency Locator Transmitter (or Emergency Locator Transmitter - Distress Tracker – ELT-DT). The Emergency Locator Transmitter (ELT) industry and related safety/investigative/regulatory experts have been working an update to the ELT to support pre-crash distress tracking capabilities under EUROCAE/RTCA with an update of the Minimum Operational Performance Specification (MOPS) for the ELT; ED-62B/DO-204B. When published (expected to take place in 2018) this will represent the most comprehensive set of requirements available for an ADT compliant architecture.

Finally, the ICAO Annex 6 SARPS for normal tracking and the associated guidance material Circular 347, lay out the requirements and implementation guidance for the underlying normal tracking capability that provides the bulk of the tracking capability in the GADSS CONOPS and is itself a very major step forward in aircraft tracking capabilities.

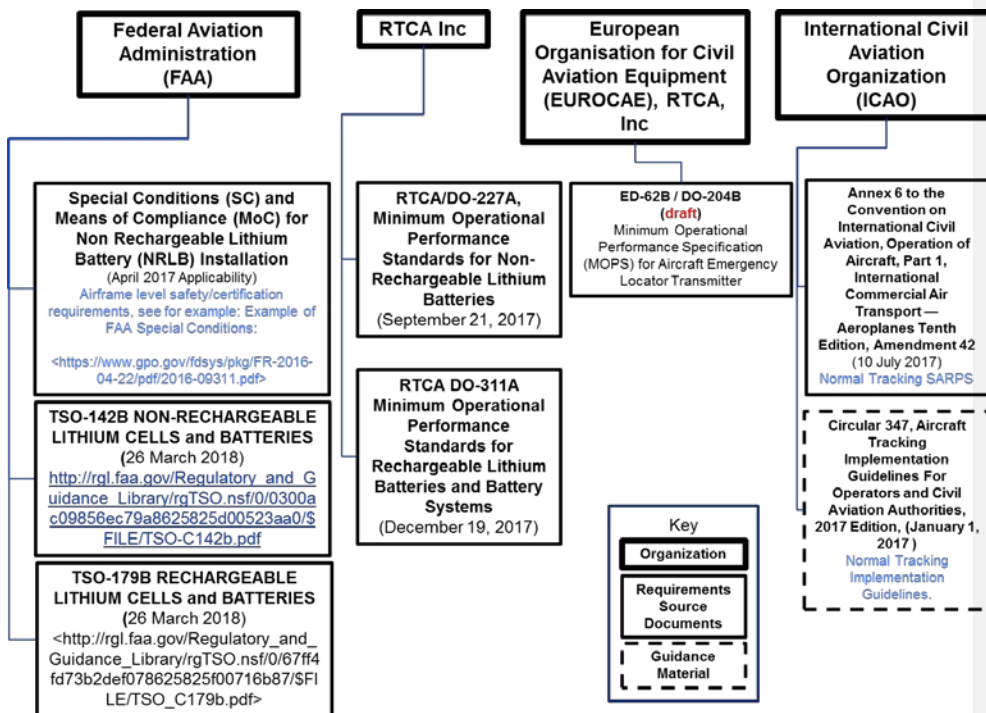

Figure 5: Related or Relevant Requirement Sources

STRAWMAN FOR ARINC PROJECT PAPER 680

Figure 6 illustrates the relationships between the major ADT requirements sources;

- The core ICAO Annex 6 SARPS reference the ED-237 distress detection criteria.
- The GADSS CONOPS takes the Annex 6 capabilities and integrates these into a Global Distress and Safety System (GADSS). A key proposed component of the GADSS is the central distress data repository which is described, in terms of requirements and processes in the DTR white paper.
- The draft Document 10054 manual, refers directly to the Annex 6 requirements and provides guidance material on key aspects of these requirements.
- The EU Commission regulation generally follows ICAO Requirements in terms of applicability, implementation date and equipage options (with respect to ELTs) but uses the location of an end of flight requirement as opposed to a 1 minute tracking requirement.
- The ED 2016-012 explicitly does not include AMC or GM for distress tracking, these will be issued following the release of document 10054.

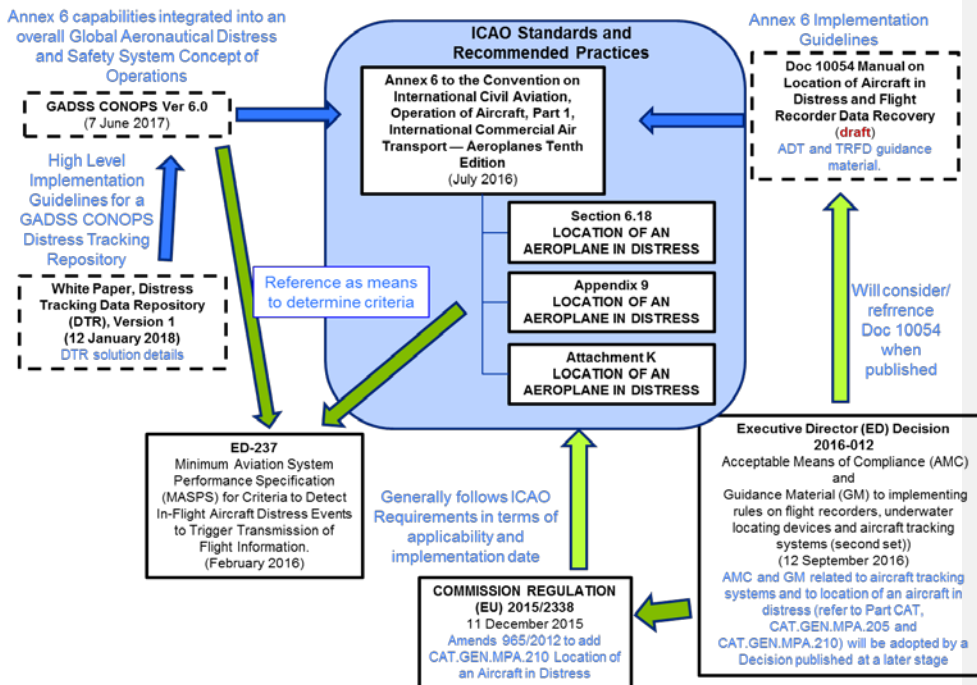

Figure 6: Relationships between Key ADT Requirements Sources

Figure 7 shows a timeline with key document and requirements release dates or applicability dates.

A key aspects shown in this figure are the limited implementation time available between the planned availability of the EASA AMC and GM and the January 2021 new production implementation date. This

STRAWMAN FOR ARINC PROJECT PAPER 680

18 month period is in contrast to typical industry flow times for procurement, development, qualification and certification of 30 months, and are probably actually worse due to the need to certify associated ground segments. The availability of significant industry work and systems in this area may be a key enabler for success under this very challenging time line.

Another key aspect of this timeline is the relatively recent maturation of major Lithium battery requirements updates – this in part reflects an industry that is still coming up the learning curve of how to use Lithium batteries in ways that will meet the current requirements.

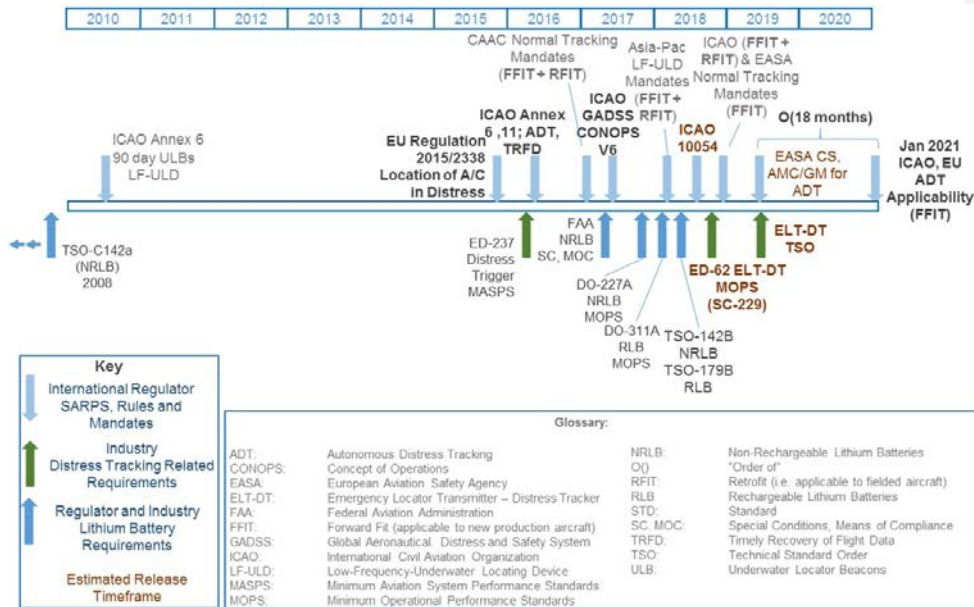

Figure 7: High Level Annex 6/GADSS ADT Related Requirements Timeline

2.3 High Level Summary of Requirements Covered in Key Distress Requirements Sources

2.3.1 Annex 6 ADT Requirements

Figure 8 summarizes the Annex 6 distress tracking requirements. These are a concise set of high level performance and size and date applicability requirements in section 6.18 including the key requirements of distress tracking, implementation date, new production aircraft applicability and medium and larger aircraft applicability as well as operator responsibility:

6.18.1 All aeroplanes of a maximum certificated take-off mass of over 27 000 kg for which the individual certificate of airworthiness is first issued on or after 1 January 2021, shall autonomously transmit information from which a position can be determined by the operator at least once every minute, when in distress, in accordance with Appendix 9.

STRAWMAN FOR ARINC PROJECT PAPER 680

6.18.3 The operator shall make position information of a flight in distress available to the appropriate organizations, as

Appendix nine provides further development of these requirements, especially in the area of detailing autonomous aspects and organizations to be notified. Attachment K provides supplemental/background information and allowable equipment (ADT/Fixed ELT) combinations. The related section 6.17.3 on Emergency Locator Transmitters (ELT) also addresses equipment and with a note that there is no requirement for an automatic ELT when an ADT is present.

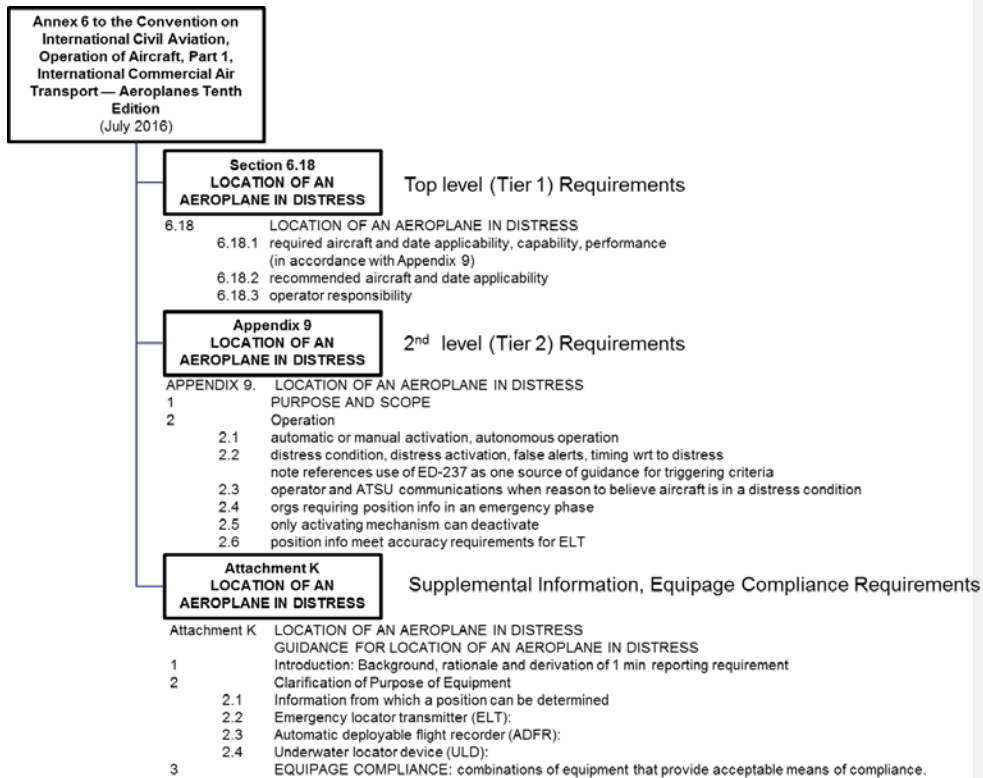

Figure 8: Autonomous Distress Tracking Annex 6 Summary

2.3.2 GADSS CONOPS ADT Requirements

Figure 9 and Figure 10 summarize the GADSS CONOPS sections and requirements. The CONOPS provides an end-to-end system and process perspective. It develops the Distress Tracking Data Repository (DTR) concept as a key potential integration function for the GADSS system of systems and demonstrates in sequence diagram outlined scenarios how information to and from the DTR will flow. The DTR approach, as laid out in the CONOPS is potentially a potent enabler for much more timely and targeted distress information flows on a world wide scale

STRAWMAN FOR ARINC PROJECT PAPER 680

and potentially a very straight forward way to integrate the data from multiple distinct systems operating on thousands of aircraft.

Global Aeronautical Distress and Safety Systems (GADSS) Concept of Operation (CONOPS) Ver 6.0
(7 June 2017)

- 3.2 Autonomous Distress Tracking Function
 - 3.2.1 Intent (6 NM radius)
 - 3.2.2 On board system performance: position, automatically, 1/min when in distress.
 - 3.2.3 Autonomy
 - 3.2.4 Operator notification of distress, ability to deliver tracking info to SAR
 - 3.2.5 Distress detection and triggering, distress tracking, manual activation
 - Note ED-237 as guidance
 - 3.2.8 Distress recovery and deactivation
 - 3.2.9 Aircraft operator activation is possible
 - 3.2.10 State of operator approval criteria that could be considered
- 3.3 Post Flight Localization and Recovery Function
 - 3.3.1 1 NM or better position for SAR from ELT or beacon for SAR onsite guidance
 - 3.3.2 Post flight localization and Recovery Function specifies multiple types of equipment
 - Emergency Locator Transmitters
 - 3.3.3 Primary purpose of ELT is to locate survivors
 - Underwater Locating Devices
 - 3.3.4 Underwater beacons
 - Flight Recorder Data Recovery
 - 3.3.5 Timely recovery of flight recorder data
 - 3.3.6 Need and annex 6 provisions for timely recovery of flight recorder data
 - 3.3.7 Potential for long recovery times or non-recovery cases for flight recorder data
- 3.4 Information sharing and Processes for the Notification of a Distress Condition
 - 3.4.1 RCC to be alerted in case of distress condition, alerting sequences per Annex 11
 - 3.4.2 Appendix A examples
 - 3.4.2(2) RCC will have access to aircraft position info
 - 3.4.3 Position info available to RCC, ATS and operator via distress tracking data repository, data requirements
 - 3.4.4 Operator responsibility to submit info to repository
 - 3.4.5 Normal tracking info retained by operator and may be requested by RCC and sent to repository
 - 3.4.6 Distress information sharing requirements, global coverage and interoperability, maintenance of information accuracy and completeness

Figure 9: Autonomous Distress Tracking GADSS CONOPS Summary (1 of 2)

STRAWMAN FOR ARINC PROJECT PAPER 680

Global Aeronautical Distress and Safety Systems (GADSS) Concept of Operation (CONOPS) Ver 6.0 (7 June 2017)	
3.5	Point of contact repository services
3.5.1	Operator with potential distress communicates to ATS
3.5.2	Point of Contact (PoC) repository with ATS contact info
3.5.3	ATS need to contact operators, PoC repository with operator info
3.5.4	GADSS info management ensures up-to-date and accurate PoC repositories
3.6	Frequency Spectrum Considerations
3.6.1	Operated in correct bands, licensed by appropriate authorities, protected aeronautical safety or distress spectrum for ADT
4	GADSS Operation .
4.1	General .
4.2	Procedures for declaring an emergency phase
4.3	Procedures for the emergency phase RCC Actions during Emergency Phases ATS and RCC relationship with Aircraft Operators ATS information to the aircraft operator (ICAO Annex 11, 5.5)
4.4	Procedures for cancellation of an emergency phase
5	GADSS Implementation
5.1	ICAO annex provisions with applicability 2018 - 2021
5.2	GADSS Implementation Work Programme
6	Concept Scenarios
Appendix A	Information sharing and Processes for the Notification of a Distress Condition
Appendix B	Improvement Areas in Current Operating Environment
B.1	Aircraft Systems
B.2	Air Traffic Services (ATS)
B.3	The Search and Rescue (SAR) System
B.4	Information Management
Appendix C	Concept Scenario
Appendix D	Terms and abbreviations .

Figure 10: Autonomous Distress Tracking GADSS CONOPS Summary (2 of 2)

2.3.3 ICAO ADT Guidance Material

Figure 11 summarizes the contents and focus for two key ICAO guidance documents, Document 10054 and the White paper on the DTR.

Document 10054 addresses the requirements in Annex 6 and does not assume the DTR, it provides clarification on important aspects such as operational requirements in the case of the loss of aircraft power. It, along with the GADSS CONOPS, identifies an ongoing requirement for a homing beacon (e.g. the 121 MHz beacons) that search and rescue teams use to localize a downed aircraft in broken or jungle type terrain. This beacon requirement may strongly imply that a fixed ELT type functionality is still a significant requirement.

The DTR white paper describes requirements for the implementation of a DTR, including performance requirements, key stakeholders and security requirements.

STRAWMAN FOR ARINC PROJECT PAPER 680

<p style="text-align: center;"> ICAO Document 10054 Manual on Location of Aircraft in Distress and Flight Recorder Data Recovery (Final Draft March 2018) </p>	<p style="text-align: center;"> White Paper, Distress Tracking Data Repository (DTR), Version 1 (12 January 2018) </p>
<p>Chapter 1. Introduction</p> <p>1.1 Background</p> <p>1.2 Objectives and Scope</p> <p>1.3 Global Aeronautical Distress Safety System</p> <p>Chapter 2. Guidance for location of aircraft in distress</p> <p>2.1 Introduction</p> <p>2.2 Applicability and intent of the provisions</p> <p>2.3 Aeroplane in a distress condition</p> <p>2.4 ADT System overview</p> <p>2.5 General Requirements</p> <p>2.6 Operator Processes</p> <p>2.7 ADT Information Management</p> <p>2.8 ATSU Processes</p> <p>2.9 RCC Processes</p> <p>Appendix 1 to Chapter 2 Operator ADT sub-system Performance metrics</p>	<p>EXECUTIVE SUMMARY</p> <p>DEFINITIONS</p> <p>REFERENCE DOCUMENTS</p> <p>1.0 BACKGROUND</p> <p>2.0 HIGH LEVEL OBJECTIVES OF THE DOCUMENT</p> <p>3.0 OPERATIONAL FRAMEWORK FOR THE USE OF THE DTR</p> <p>4.0 DTR PERFORMANCE</p> <p>4.1 Database capacity</p> <p>4.2 Maximum response time</p> <p>4.3 Database security</p> <p>4.4 Denial of service protection</p> <p>4.5 Virus protection</p> <p>4.6 Password encryption</p> <p>4.7 Intrusion detection</p> <p>5.0 REQUIRED DATA FOR THE DTR</p> <p>5.1 SWIM compliance for information exchanges</p> <p>5.2 DTR data source – reliability of data/source</p> <p>5.3 DTR access restrictions</p> <p>6.0 DTR STAKEHOLDERS</p> <p>6.1 DTR administrator</p> <p>6.2 Criteria for being a contributor</p> <p>6.3 Contributor accreditation</p> <p>6.4 DTR data users</p> <p>6.5 User (entity) accreditation</p>

Figure 11: Autonomous Distress Tracking ICAO Guidance Material Summary

2.3.4 ICAO Normal Tracking Requirements

Figure 11 summarizes key normal tracking requirements from Annex 6, the GADSS CONOPS and from Circular 347. These are not distress tracking requirements but represent the underlying tracking capability and associated operator processes that provide a complimentary and in the case of operator processes, an underlying infrastructure for distress tracking capabilities.

STRAWMAN FOR ARINC PROJECT PAPER 680

Annex 6 to the Convention
on International Civil
Aviation, Operation of
Aircraft, Part 1, International
Commercial Air Transport
— Aeroplanes Tenth
Edition, Amendment 42
(10 July 2017)

3.5 AIRCRAFT TRACKING

- 3.5.1 The operator shall establish an aircraft tracking capability to track aeroplanes throughout its area of operations
 - 3.5.2 Recommendation.— operator should establish tracking throughout area of operations using automated reporting at 15 minute intervals, aircraft size applicability ATS capability does not support 15 minute or better interval
 - 3.5.3 The operator shall track the position of an aeroplane through automated reporting at least every 15 minutes for the portion(s) of the in-flight operation(s) that is planned in an oceanic area(s) aircraft size applicability, ATS capability does not support 15 minute or better interval
 - 3.5.4 The State of the Operator may use a risk assessment based approach to determining tracking requirements.
 - 3.5.5 The operator shall establish procedures, approved by the State of the Operator, for the retention of aircraft tracking data
- Note.— Refer to 4.2.1.3.1 for operator responsibilities when using third parties for the conduct of aircraft tracking under 3.5.

Global Aeronautical
Distress and Safety
Systems (GADSS) Concept
of Operation (CONOPS) Ver
6.0
(7 June 2017)

- 3.1 Aircraft Tracking Function
 - 3.1.1 using current technologies to support SAR - 4D position at 15 minute intervals
 - 3.1.2 requirements for operators
 - 3.1.3 not required if ATS surveillance at 15 min or better interval
 - 3.1.4 ANSP need to make surveillance capability info available
 - 3.1.5 higher rates for abnormal operations can be supported
 - 3.1.6 for operator receipt of tracking data directly, communication with ANSP and SAR required for missed reports.
- Aircraft Tracking Service Providers
 - 3.1.7 responsibility with operator, can be provided by 3rd party
 - 3.1.8 aircraft tracking information recording requirement
 - 3.1.9 during emergency phase make log available

Circular 347,
Aircraft Tracking
Implementation Guidelines
For Operators and Civil
Aviation Authorities,
2017 Edition,
(January 1, 2017)

- 1. Introduction
 - 2. Aircraft tracking requirements
 - 3. Implementation Planning
 - 4. Operator aircraft tracking policy, process and procedures
 - 5. Preflight planning, flight commencement and in-flight considerations
 - 6. Operator monitoring – policy, process and procedures
 - 7. Operator monitoring of aircraft experiencing an abnormal operation or event
 - 8. Operator missed reports notification to ATS unit
- Appendix A Operator 4D/15 tracking process flowchart
Appendix B Aircraft tracking risk management flowchart
Appendix C Missed 4D/15 position report form for operator

Figure 12: Normal Tracking Requirement Sources Summary

2.3.5 EU Regulations for Aircraft Tracking and Aircraft in Distress Requirements

The EU COMMISSION REGULATION (EU) 2015/2338 of 11 December 2015 amended Commission Regulation 965/2012 to add CAT.GEN.MPA.205 Aircraft tracking system — Aeroplanes and CAT.GEN.MPA.210 Location of an Aircraft in Distress.

These in many key ways follow the ICAO Annex 6 requirements with an exception being the use of the “to accurately determine, following an accident where the aeroplane is severely damaged, the location of the point of end of flight” requirement in place of the transmitting information at once per minute requirement used in ICAO. This location of the point of end of flight provides a broader range of solutions, including the use of automatically deployable beacons or ELTs.

Some key excerpts from these sections:

Intent and description of autonomy

“4) It is necessary to take into consideration the disappearance of flight MH370 on 8 March 2014 and the recommendations made by the multidisciplinary meeting of the ICAO on global tracking of 12 and 13 May 2014. The position of public transport aircraft should be known at all times, even in a remote location, in order to facilitate the location of the aircraft in case of an abnormal behaviour, an emergency or an accident. Whenever possible, the aircraft tracking means should be robust to loss of normal electrical power on board and should not offer any control to disable it during the flight. Therefore, Regulation (EU) No 965/2012 should be amended in order to include

STRAWMAN FOR ARINC PROJECT PAPER 680

additional requirements related to means to track aircraft on a global basis, including over oceans and remote areas.”

Definitions:

‘(8a) “aircraft tracking” means a ground based process that maintains and updates, at standardised intervals, a record of the four dimensional position of individual aircraft in flight;

(8b) “aircraft tracking system” means a system that relies on aircraft tracking in order to identify abnormal flight behaviour and provide alert;’.

Normal Tracking Requirements

“(c) The following point CAT.GEN.MPA.205 is inserted:

‘CAT.GEN.MPA.205 Aircraft tracking system — Aeroplanes

- (a) By 16 December 2018 at the latest, the operator shall establish and maintain, as part of the system for exercising operational control over the flights, an aircraft tracking system, which includes the flights eligible to (b) when performed with the following aeroplanes:
- (1) aeroplanes with an MCTOM of more than 27 000 kg, with an MOPSC of more than 19, and first issued with an individual CofA before 16 December 2018, which are equipped with a capability to provide a position additional to the secondary surveillance radar transponder;
 - (2) all aeroplanes with an MCTOM of more than 27 000 kg, with an MOPSC of more than 19, and first issued with an individual CofA on or after 16 December 2018; and
 - (3) all aeroplanes with an MCTOM of more than 45 500 kg and first issued with an individual CofA on or after 16 December 2018.
- (b) Flights shall be tracked by the operator from take-off to landing, except when the planned route and the planned diversion routes are fully included in airspace blocks where:
- (1) ATS surveillance service is normally provided which is supported by ATC surveillance systems locating the aircraft at time intervals with adequate duration; and
 - (2) the operator has provided to competent air navigation service providers necessary contact information.’.”

We interpret this requirement as meaning that medium/large aircraft delivered before Dec. 16, 2018 (>27,000kg) which have ADS-C/SATCOM installed shall implement normal tracking unless they are operating in airspace fully covered by a suitable surveillance capability and that large aircraft delivered after Dec. 16, 2018 (>45,500kg) MUST have ADS-C/SATCOM installed and an suitable network service unless they are operating in airspace fully covered by a suitable surveillance capability.

Distress Tracking Requirements

“(c) The following point CAT.GEN.MPA.210 is inserted:

‘CAT.GEN.MPA.210 Location of an aircraft in distress — Aeroplanes

The following aeroplanes shall be equipped with robust and automatic means to accurately determine, following an accident where the aeroplane is severely damaged, the location of the point of end of flight:

- (1) all aeroplanes with an MCTOM of more than 27 000 kg, with an MOPSC of more than 19 and first issued with an individual CofA on or after 1 January 2021; and

STRAWMAN FOR ARINC PROJECT PAPER 680

- (2) all aeroplanes with an MCTOM of more than 45 500 kg and first issued with an individual CofA on or after 1 January 2021.”

This generally follows the ICAO implementation with the broadening of the potential implementation means to include those that accurately determine the point of the end of flight.

ELT Equipage Requirements

“(h) CAT.IDE.A.280 is amended as follows:

- (i) point (a) is replaced by the following:

‘(a) with an MOPSC of more than 19 shall be equipped with at least:

- (1) two ELTs, one of which shall be automatic, or one ELT and one aircraft localisation means meeting the requirement of CAT.GEN.MPA.210, in the case of aeroplanes first issued with an individual CofA after 1 July 2008; or
- (2) one automatic ELT or two ELTs of any type or one aircraft localisation means meeting the requirement of CAT.GEN.MPA.210, in the case of aeroplanes first issued with an individual CofA on or before 1 July 2008.’.

- (ii) point (b) is replaced by the following:

‘(b) Aeroplanes with an MOPSC of 19 or less shall be equipped with at least: (1) one automatic ELT or one aircraft localisation means meeting the requirement of CAT.GEN.MPA.210, in the case of aeroplanes first issued with an individual CofA after 1 July 2008; or (2) one ELT of any type or one aircraft localisation means meeting the requirement of CAT.GEN. MPA.210, in the case of aeroplanes first issued with an individual CofA on or before 1 July 2008.’.

Our interpretation of these requirements is that:

For aircraft delivered AFTER July 1, 2008: If the aircraft meets the .210 distress tracking requirement, an automatic-fixed ELT does NOT need to be installed (or can be removed).

For aircraft delivered BEFORE July 1, 2008: If the aircraft meets the .210 distress tracking requirement, an ELT is not required to be installed.

2.3.6 EUROCAE ED-237 MASPS for Criteria to Detect In-Flight Aircraft Distress Events to Trigger Transmission of Flight Information

These MASPS were published February 2016. These are performance based requirements and allow for alternative means of meeting objectives

“... Although specific test procedures are cited, it is recognised that other methods may be used. Alternate procedures may be used if it can be demonstrated that they provide at least equivalent performance.”

These requirements have two primary objectives:

“The overall objective of this specification is to make sure that the criteria used to trigger in-flight transmission maximises the probability of in-flight detection of an upcoming catastrophic event and minimises the probability of nuisance activation ”

An “In-flight distress event is a situation which, if left uncorrected, is likely to result in an accident.”

The key performance requirements are found in CHAPTER 3 IN-FLIGHT DISTRESS EVENT DETECTION AND TRIGGERING CRITERIA PERFORMANCE

STRAWMAN FOR ARINC PROJECT PAPER 680

Some highlights of the requirements in chapter 3:

- 1.) Compliance one means of assuring logic performs satisfactorily, provides a minimum set of scenarios to be detected.
- 2.) Logic may be inhibited based on flight phase to limit nuisance triggers (inhibition does not cancel an active trigger)
- 3.) Persistence time or minimum occurrence duration should be part of logic – key way to balance ability to detect while limiting nuisance trigger
- 4.) Distress Condition Scenarios:
 - “Scenario 1: Unusual attitude. The conditions may include, but are not limited to, excessive values of roll, pitch and yaw and their corresponding rates of change
 - Scenario 2: Unusual speed. The conditions may include, but are not limited to, excessive vertical speed, stall condition, low airspeed, overspeed or other speed conditions.
 - Scenario 3: Collision with terrain. The conditions may include, but are not limited to, high rate of closure to terrain or inappropriate altitude for the current position.
 - Scenario 4: Total loss of thrust/propulsion on all engines. The parametric data used to define this condition may be engine performance parameters or other parameters that result from loss of thrust.”
- 5.) “transmission cancellation notification” ; aircraft exists distress condition, system returns to normal state
- 6.) Nuisance triggers – system credibility issue and potential to overload search and rescue systems
 - “the overall in-flight event detection and triggering system should meet a nuisance rate objective of no more than 2 nuisance triggers per 100 000 Flight Hours. ”
 - “The portion of the overall nuisance rate attributable to the triggering logic and causing a false alert to SAR providers, shall be no more than 1 nuisance trigger per 100 000 Flight Hours. ”
 - Consideration of sources of nuisance triggers – hardware failures, design defects, maintenance actions etc.
- 7.) Interface with triggered system: distinct trigger and cancellation indications

Discussion – the nuisance trigger requirement is one of the more critical requirements in this document - the 10^{-5} probability is a very high standard. It was noted by OEMs that auto-pilot software ex.: CAT3 auto-land, and end of runway detection etc. has the same strict requirements. Alternate views expressed were - those are very predictable set of circumstances, and this distress detection trigger logic requires detection of rare and non-normal conditions. This will be one of the most challenging aspects for the technical implementation of ADTs as well as for certification and operational usage.

Highlights or key points from Chapter 4 PROCEDURES FOR PERFORMANCE REQUIREMENT VERIFICATION include:

- 1.) Event Detection Rate Verification:
 - “One means to verify the event detection rate is to run the logic on an appropriate database of flight data from real accidents and incidents. Official investigation authorities have provided a

STRAWMAN FOR ARINC PROJECT PAPER 680

database of 68 datasets from real commercial air transport aeroplane accidents and incidents which is available upon request at the following address "accident.database@bea-fr.org". See Appendix 1 for details. For some events in the database, all the parameters necessary for in-flight triggering may not be available.

NOTE: Event detection rate verification using only the datasets provided by the investigation agencies is incomplete. If those are the only accident datasets used, additional analytical verification is required to ensure that all scenarios defined in Chapter 3 are captured.

For the database used in the verification, the detection rate shall be **100%**, except when justified."

2.) Nuisance Trigger Rate Verification: potentially a data base of representative data or analytical approach.

3.) Cancellation cases and Erroneous Cancellations Rate Verification:

2.4 Key Requirements Terms Discussion and Definitions

While the previous sections generally presented and summarized the requirements in one document at a time, this section takes the approach of analyzing key requirements terms across multiple sources to develop an integrated understanding of the key requirements..

2.4.1 Key Terms Summary

Autonomous Distress Tracking (ADT) - is the capability that enables the aeronautical safety system to identify and track an aircraft in distress.

Note: this capability is described under 'Location of an Aeroplane in Distress' in ICAO Annex 6 Part 1; and in EU 2015/2338 amending EU 965/2012, CAT.GEN.MPA.210.

Autonomous Distress Tracking system - identifies the aircraft's distress condition and autonomously transmits information from which the aircraft position can be determined at least once every minute. ADT system shall be resilient to failures of the aircraft's electrical power, navigation, communication systems, as well as to human-machine interface errors.

Autonomy - is the ADT system's ability to perform its function independently, as long as practical, during the distress condition.

Distress - is a condition in which the aircraft behavior, if left uncorrected, is likely to result in an accident.

Notes:

- This condition is determined by the ADT system with airborne system real-time analysis and / or ground processes.

- ADT distress notification may be used to determine the start of the Distress Phase (a.k.a. DETRESFA), as defined in ICAO Annexes 11 and 12.

Nuisance alert - an alert generated by a system that is functioning as designed but which is inappropriate or unnecessary for the particular condition.

STRAWMAN FOR ARINC PROJECT PAPER 680

Resilience / robustness to failure - it is a measure of the sensitivity to failures, malfunctions, human errors and violations. The more resilient the system is, the less susceptible it is to failures.

Note: ADT system should be resilient to failures.

2.4.2 Source documents and associated discussions

2.4.2.1 Autonomous Distress Tracking (ADT) and Autonomous Distress Tracking system

Sources:

- ICAO GADSS CONOPS – v. 6.0 (section 1.2 – definitions)

"The capability using transmission of information from which a position of an aircraft in distress can be determined at least once every minute and which is resilient to failures of the aircraft's electrical power, navigation and communication systems.

Note: this capability is described under 'Location of an Aeroplane in Distress' in ICAO Annex 6 Part 1"

- ICAO Annex 6 (section 6.18.1 – Location of an Aeroplane in Distress)

"All aeroplanes of a maximum certificated take-off mass of over 27 000 kg for which the individual certificate of airworthiness is first issued on or after 1 January 2021, shall autonomously transmit information from which a position can be determined by the operator at least once every minute, when in distress, in accordance with Appendix 9."

- EUROCAE ED-237 (section 1.2.1.1 – background)

"The intent of this ADT System is to use on-board systems that can detect an emergency situation and broadcast position, or distinctive distress signals from which the position can be derived, on protected frequencies and, depending on its application on each aircraft, to be automatically activated or manually activated at any time."

- EU 2015/2338 amending EU 965/2012 (CAT.GEN.MPA.210 Location of an aircraft in distress — Aeroplanes)

"The following aeroplanes shall be equipped with robust and automatic means to accurately determine, following an accident where the aeroplane is severely damaged, the location of the point of end of flight:

(1) all aeroplanes with an MCTOM of more than 27 000 kg, with an MOPSC of more than 19 and first issued with an individual CofA on or after 1 January 2021; and

(2) all aeroplanes with an MCTOM of more than 45 500 kg and first issued with an individual CofA on or after 1 January 2021."

Discussions:

STRAWMAN FOR ARINC PROJECT PAPER 680

- Only ICAO CONOPS document provides a concise definition for ADT.
- ICAO Annex 6 and EU 2015/2338 does not explicitly address ADT, but "location of an aircraft in distress". These documents that use the "location of an aircraft in distress" expression emphasize that the aircraft is to be found within 6 NM.
- Both ICAO documents and ED-237 mention transmission of information from which a position of an aircraft can be determined. EU regulation does not explicitly mention it. However, it is implied on the concept, otherwise, how could the aircraft be found if nothing is transmitted?
- Both ICAO documents state that position of the aircraft can be determined at least once a minute. ED-237 and EU regulation do not mention the rate in which the position of the aircraft can be determined. However EU regulation mentions the 6 NM concept, which Attachment K of ICAO Annex 6 explains that it is associated with the aircraft position that is known one minute prior to the accident. Therefore, implicitly, the EU regulation also addresses the 1 minute rate.
- ICAO documents imply that it is not necessary to transmit the aircraft position, but a signal from which aircraft position can be derived.
- How much resilient/robust (resilience is mentioned in ICAO CONOPS and robustness in EU regulation) to failures this capability should be? ICAO GADSS, v. 6.0, adds some clarification by indicating that the necessary resilience is as "practically possible" to failures of the aircrafts' electrical power, navigation and communication systems as well as to human factors. (Refer to the correspondent term in this glossary)
- Autonomous transmission (all sources). Autonomous detection and triggering, as well? What is autonomy? (Refer to the correspondent term in this glossary)
- Aircraft in distress (all sources, explicitly or implicitly). What is distress? (Refer to the correspondent term in this glossary)
- On the 08/08 meeting, it was determined that it is better to have two separate definitions: ADT and ADT system. ADT explains the associated capability, while ADT system describes the corresponding system.

2.4.2.2 Autonomy

Sources:

- ICAO GADSS CONOPS – v. 6.0

(section 3.2.3 – autonomous distress tracking function)

"The ADT function uses on board systems to broadcast aircraft position (latitude and longitude), or distinctive distress signals from which the aircraft position and time can be derived. The aircraft position information will be transmitted, without the need for flight crew action, at least once every minute, when an aircraft is in a distress condition. An aircraft is in a distress condition when it is in a state that, if the aircraft behaviour event is left uncorrected, may result in an accident."

(section 3.2.3 – autonomous distress tracking function)

"In terms of the autonomy, the ADT function will transmit as long as practically possible during the distress condition. "As practically possible" refers to a means to achieve resilience to failures of

STRAWMAN FOR ARINC PROJECT PAPER 680

the aircrafts' electrical power, navigation and communication systems as well as to human factors. The onboard component of the ADT function will be designed such that, in the event of aircraft electrical power loss, it will continue transmitting for the expected duration of the remaining flight."

- EUROCAE ED-237 (section 1.2.1.1 – background)

"The intent of this ADT System is to use on-board systems that can detect an emergency situation and broadcast position, or distinctive distress signals from which the position can be derived, on protected frequencies and, depending on its application on each aircraft, to be automatically activated or manually activated at any time."

- EU 2015/2338 amending EU 965/2012(CAT.GEN.MPA.210 – location of an aircraft in distress - aeroplanes)

"The following aeroplanes shall be equipped with robust and automatic means to accurately determine, following an accident where the aeroplane is severely damaged, the location of the point of end of flight:

(1) all aeroplanes with an MCTOM of more than 27 000 kg, with an MOPSC of more than 19 and first issued with an individual CofA on or after 1 January 2021; and

(2) all aeroplanes with an MCTOM of more than 45 500 kg and first issued with an individual CofA on or after 1 January 2021."

- FAA AC 25.1302-1 (section 5.6 – system behavior)

"(...) (S)ystems designed to operate autonomously, in the sense that they require very limited or no human interaction, are referred to as "automatic systems." Such systems are switched "on" or "off" or run automatically, and are not covered by § 25.1302(c). Examples include Full Authority Digital Engine Controls (FADEC) and yaw dampers. Specific detailed guidance for automatic systems can be found in relevant paragraphs of part 25."

Discussions:

- There are two meanings to the term "autonomy". In the first meaning, autonomy refers to the amount of time a certain equipment is expected to function. In this meaning, autonomy is closely related to the term "resilience/robustness to failure".

- In the second meaning, autonomy refers to independence, system self-control, system design that requires limited or no human interaction.

- Both meanings permeate the ADT functionality.

- in team discussions, it was introduced a definition that would emphasize the independence aspect, as well as the resilience aspect.

2.4.2.3 Distress

Sources:

- ICAO GADSS CONOPS – v. 6.0 (section 1.2 – definitions)

- ICAO Annex 11 (chapter 1 – definitions)

- ICAO Annex 12 (chapter 1 – definitions)

STRAWMAN FOR ARINC PROJECT PAPER 680

"Distress phase: A situation wherein there is reasonable certainty that an aircraft and its occupants are threatened by grave and imminent danger or require immediate assistance."

- ICAO GADSS CONOPS – v. 6.0

(section 3.2.5 – high level objectives of the GADSS)

"The GADSS is designed to address three specific issues;

- a) the late notification of SAR services when aircraft are in distress (as defined in ICAO Annex 11),
- b) missing or inaccurate end of flight aircraft position information i.e. the location of wreckage and
- c) lengthy and costly retrieval of flight data for accident investigation."

(section 3.2.5 – autonomous distress tracking function)

"To identify a distress condition, the aircraft state will be analysed in real-time by aircraft systems or ground processes and the use of event detection and triggering criteria logic will initiate the notification of the alert to assist locating the aircraft in distress."

(section 3.2.5.1 – autonomous distress tracking function)

"The triggering criteria may include analysis of unusual attitudes, unusual altitudes, unusual speeds, potential collision with terrain, total loss of thrust/propulsion on all engines, Mode A squawk codes, etc. The triggers will be defined making sure that the criteria used maximises the probability of detection of an upcoming catastrophic event."

(section 3.2.5.2 – autonomous distress tracking function)

"Note: Further guidance regarding in - flight event detection and triggering criteria may be found in the EUROCAE ED - 237 Minimum Aviation Performance Specification (MASPS) for Criteria to Detect In - Flight Aircraft Distress Events to Trigger Transmission of Flight Information."

- ICAO Annex 11 (section 5.2 – notification of rescue coordination centres)

"5.2.1 Without prejudice to any other circumstances that may render such notification advisable, air traffic services units shall, except as prescribed in 5.5.1, notify rescue coordination centres immediately an aircraft is considered to be in a state of emergency in accordance with the following:

(...)

c) Distress phase when:

- 1) following the alert phase, further unsuccessful attempts to establish communication with the aircraft and more widespread unsuccessful inquiries point to the probability that the aircraft is in distress, or when

STRAWMAN FOR ARINC PROJECT PAPER 680

2) the fuel on board is considered to be exhausted, or to be insufficient to enable the aircraft to reach safety, or when

3) information is received which indicates that the operating efficiency of the aircraft has been impaired to the extent that a forced landing is likely, or when

4) information is received or it is reasonably certain that the aircraft is about to make or has made a forced landing, except when there is reasonable certainty that the aircraft and its occupants are not threatened by grave and imminent danger and do not require immediate assistance."

- ICAO Annex 6, (Appendix 9, item 2.2: operation)

"An aircraft is in a distress condition when it is in a state that, if the aircraft behaviour event is left uncorrected, can result in an accident."

- EUROCAE ED-237

(section 1.8.1 – definition of terms)

"In-flight distress event: A situation which, if left uncorrected, is likely to result in an accident."

(section 3.2.1 – scenarios)

"The scenarios listed below were developed based on analyses which included reviews of previous events and represent the minimum set which should be detected by the logic. They are identified by conditions which, if left uncorrected, are likely to result in an accident. Manufacturers may include additional scenarios or combine scenarios, provided that they do not impair the overall efficiency and/or reliability of the triggering logic.

Each condition is defined by parametric data thresholds which may differ depending on the type of aircraft and its mission (as for example military training phase, aerial work, Search And Rescue civil, passenger transport).

Scenario 1: Unusual attitude. The conditions may include, but are not limited to, excessive values of roll, pitch and yaw and their corresponding rates of change

Scenario 2: Unusual speed. The conditions may include, but are not limited to, excessive vertical speed, stall condition, low airspeed, overspeed or other speed conditions.

Scenario 3: Collision with terrain. The conditions may include, but are not limited to, high rate of closure to terrain or inappropriate altitude for the current position.

Scenario 4: Total loss of thrust/propulsion on all engines. The parametric data used to define this condition may be engine performance parameters or other parameters that result from loss of thrust."

Discussions:

- There is a "distress phase", which is referenced in ICAO Annex 11 and 12, plus the GADSS CONOPS. This is one of the three emergency phases (uncertainty, alert and distress) defined in the Search and Rescue operating procedures.

STRAWMAN FOR ARINC PROJECT PAPER 680

- The distress phase is a period of time, in which the Rescue Coordination Centre (RCC) and Air Traffic Control (ATC) have to follow a number of procedures (ICAO Annex 11 and 12).
- Criteria are provided in item 5.2.1 of ICAO Annex 11 for the RCC and the ATC to determine the start of the distress phase. This initial time is mainly defined from the point of view of the RCC and the ATC.
- On the other hand, the ICAO GADSS CONOPS, the Annex 6 and EUROCAE ED-237 mention a distress condition, which roughly corresponds to the initial time of the distress phase. However, this distress condition is defined mainly from the point of view of the Aircraft Distress Tracking functionality, which includes both airborne system and ground processes.
- Therefore, although all these documents refer to term "distress", the tools that are used to determine the distress condition are different. Real-time analysis of the aircraft state may be implemented by an airborne system, while the RCC may use the lapse of time in which there is no communication with the aircraft to determine the distress condition.
- For the work that is being performed in this committee, in which the focus is in the Autonomous Distress Tracking functionality, the term "distress" should be defined from this capability point of view and not the RCC's and ATC's perspective only.
- Distress logic and triggering criteria are not part of the Distress condition definition. They are functional requirements to accomplish the ADT functionality.

2.4.2.4 Nuisance alert

Sources:

- ICAO GADSS CONOPS – v. 6.0

(section 1.2 – definitions)

"**False alert.** An alert received from any source, including communications equipment intended for alerting, when no distress situation actually exists, and a notification of the alert should not have resulted."

(section 3.2.10 - autonomous distress tracking function)

"The ADT function will be approved by the State of the Operator, considering high - level performance criteria such as:

(...)

g) Minimisation of False Alerts."

- ICAO Appendix 6 (appendix 9, section 2.2 - operation)

"An aircraft is in a distress condition when it is in a state that, if the aircraft behaviour event is left uncorrected, can result in an accident. Autonomous transmission of position information shall be active when an aircraft is in a distress condition. This will provide a high probability of locating an accident site to within a 6 NM radius. The operator shall be alerted when an aircraft is in a distress condition with an acceptable low rate of false alerts. In case of a triggered transmission

STRAWMAN FOR ARINC PROJECT PAPER 680

system, initial transmission of position information shall commence immediately or no later than five seconds after the detection of the activation event."

- EUROCAE ED-237

(section 1.8.1 - definition of terms)

"Nuisance trigger: any trigger that is erroneously generated by the on-board triggering system when there is no potential for an accident."

(section 3.1 - introduction)

"In order to minimize nuisance triggers and optimize triggering logic, the logic may be inhibited or may be limited in its ability to detect distress events during the following flight phases: take-off, initial climb, final approach, landing and go-around."

(section 3.2 - triggering criteria)

"The set of triggering criteria should maximize the detection of scenarios, while limiting nuisance triggering. Excessive nuisance triggers have the potential to reduce confidence in the system as well as saturate SAR resources."

(section 3.2.2 - persistence time)

"The persistence time is the duration for which the condition(s) is true before a triggering signal is generated. The persistence time for each of the criteria should be balanced to trigger a transmission, as soon as practicable, that captures the greatest number of accidents possible while limiting the number of nuisance triggers."

(section 3.2.4 - nuisance trigger)

As defined above, a nuisance trigger is any trigger that is erroneously generated by the triggering logic when there is no potential for an accident. Keeping the rate of nuisance trigger activations low is paramount to maintaining user confidence in the overall system and to avoid saturating SAR resources. Based on input from SAR service providers regarding additional nuisance alerts due to the introduction of the in-flight activation logic, the overall in-flight event detection and triggering system should meet a nuisance rate objective of no more than 2 nuisance triggers per 100 000 Flight Hours.

Many factors could lead to a nuisance trigger activation, such as, but not limited to:

- Triggering logic,
- Erroneous input (e.g. hardware failure, corrupt data),
- Development errors or triggering system hardware failure,
- Maintenance action,
- Ground and/or flight test.

STRAWMAN FOR ARINC PROJECT PAPER 680

Addressing the reliability of hardware and the design implementation are beyond the scope of this document. The portion of the overall nuisance rate attributable to the triggering logic and causing a false alert to SAR providers, shall be no more than 1 nuisance trigger per 100 000 Flight Hours. To meet this objective, the triggering logic should implement accurate criteria specific to the target aircraft and be verified for correct operation against a database of exemplar flight data (see Chapter 4) to reduce the nuisance trigger rate. The rate may be reduced further if the triggering logic takes into account:

- The use of appropriate limit values and/or persistence times for each of the criteria to ensure the non-transient nature of an event (see § 3.2.2),
- The effect of sensor failures on the triggering logic,
- The effects of maintenance or functional check flight activities on the triggering logic."

- FAA AC 25.1322-1 (appendix 5 – definitions)

"Nuisance alert - an alert generated by a system that is functioning as designed but which is inappropriate or unnecessary for the particular condition."

Discussions:

- There is a concern about nuisance triggers and a possible high rate of false alerts.
- ED-237, particularly, lay out objectives to be met and suggest design techniques to ensure appropriate compliance with the objectives.
- ED-237 defines nuisance trigger emphasizing that the nuisance is erroneously generated. This may create some confusion. As AC 25.1322-1 points out, the nuisance is generated because the system is functioning as designed (maybe the design needs to be reviewed, but this is another matter) and not because there is an error in it (suppose that a false alert is generated by the failure of an electronic component – this cannot be interpreted as a nuisance failure). The AC 25.1322-1 definition seems to be more accurate than ED-237's. Besides, this definition should be independent from the ADT concept.

2.4.2.5 Resilience / Robustness to Failure

Sources:

- ICAO GADSS CONOPS – v. 6.0

(section 1.2 – definitions)

"Autonomous Distress Tracking (ADT). The capability using transmission of information from which a position of an aircraft in distress can be determined at least once every minute and which is resilient to failures of the aircraft's electrical power, navigation and communication systems.

Note: this capability is described under 'Location of an Aeroplane in Distress' in ICAO Annex 6 Part 1."

(section 3.2.3 – autonomous distress tracking function)

"In terms of the autonomy, the ADT function will transmit as long as practically possible during the distress condition. "As practically possible" refers to a means to achieve resilience to failures of the aircrafts' electrical power, navigation and communication systems as well as to human

STRAWMAN FOR ARINC PROJECT PAPER 680

factors. The onboard component of the ADT function will be designed such that, in the event of aircraft electrical power loss, it will continue transmitting for the expected duration of the remaining flight."

(appendix C – concept scenario)

Figure 13 GADSS CONOPS Version 6.0 Concept Scenarios (1 of 2)

The following table provides a basic analysis of the expected level of resilience in the GADSS system (the number of independent opportunities to ensure the location of end of flight is known) for each of the scenarios outlined above and is based on the defined GADSS functionality. The matrix considers four basic over-arching states:

Aircraft indication and communication systems <i>operating normally with cooperative crew</i>	A
Aircraft indication and communication systems <i>operating normally with non-cooperative crew</i>	B
Aircraft indication and communication systems <i>not operating normally with cooperative crew</i>	C
Aircraft indication and communication systems <i>not operating normally with non-cooperative crew</i>	D

It should be noted that AT is mandated to provide a 4D position every 15 minute which, on its own, will not allow identification of the end of flight location to a level of accuracy required. Likewise, voice communications on its own will rarely allow an accurate end of flight location to be determined.

Scenario Reference		PRE-END OF FLIGHT			POST – END OF FLIGHT (Focus: Rescue and Recovery)		POST – END OF FLIGHT (Focus: Recovery)	
		VOICE COMMS	AT / Surveillance	ADT automatically activated	ELT (LEGACY)	FRDR	FDR/CVR ULD	AIRFRAME ULD
1.1 – Loss of control in-flight (LOC-I) with recovery	A	Limitations ¹	YES	YES	N/A	TBD	N/A	N/A
1.2 - Engine failure in flight	A	YES	YES	NO	N/A	TBD	N/A	N/A
1.3 - Failure of communication system, failure to report position or operational status	C	NO	YES	NO	N/A	TBD	N/A	N/A
1.4 - System Component Failure (non-powerplant)	C	Limitations ¹	YES	NO	N/A	TBD	N/A	N/A
1.5 - Fuel related (FUEL)	A	YES	YES	YES	N/A	TBD	N/A	N/A
2.1 - Loss of control in-flight (LOC-I), no recovery	A	Limitations ¹	YES	YES	NO	YES	YES	YES
2.2 - Mid-Air Collision (MAC)	A	NO	YES	NO	YES	TBD	Limitations ²	Limitations ²
2.3 - In-flight break-up	A	NO	YES	NO	YES	TBD	Limitations ²	Limitations ²
2.4 - Powerplant system/component failure or malfunction (SCF-PP)	A	YES	YES	YES ³	YES ³	TBD	YES	YES

STRAWMAN FOR ARINC PROJECT PAPER 680

¹ The crew would have limited time to communicate and depending on geographical location may have been outside voice communication coverage.

² Limited to surviving the initial impact and landing in water

³ Subject to manual activation

Version: 6.0	Title: GADSS – Concept of Operations
Date: 07/06/2017	

Scenario Reference		PRE-END OF FLIGHT			POST – END OF FLIGHT (Focus: Rescue and Recovery)		POST – END OF FLIGHT (Focus: Recovery)	
		VOICE COMMS	AT / Surveillance	ADT automatically activated	ELT (LEGACY)	FRDR	FDR/CVR ULD	AIRFRAME ULD
2.5- Fire (F)	A	YES	YES	YES ³	YES ³	YES	Limitations ²	Limitations ²
2.6 – Controlled Flight into Terrain (CFIT)	B	YES	YES	TBD	YES ⁴	TBD	N/A	N/A
2.7 - Aircraft comm. system Failure	B/D	NO	NO	YES	YES ⁴	NO	YES ⁵	YES ⁵

The analysis of the concept should be conducted in a consistent manner to allow objective comparison of alternative solutions. The 'swim-lane' methodology is one approach that may be appropriate for this ConOps and is used below for illustrative purposes.

Figure 14 GADSS CONOPS Version 6.0 Concept Scenarios (2 of 2)

- ICAO Appendix 6 (appendix 9, section 2 – operation)

"The system used for the autonomous transmission of position information shall be capable of transmitting that information in the event of aircraft electrical power loss, at least for the expected duration of the entire flight."

- EU 2015/2338 (CAT.GEN.MPA.210 – location of an aircraft in distress - aeroplanes)

"The following aeroplanes shall be equipped with robust and automatic means to accurately determine, following an accident where the aeroplane is severely damaged, the location of the point of end of flight:

(1) all aeroplanes with an MCTOM of more than 27 000 kg, with an MOPSC of more than 19 and first issued with an individual CofA on or after 1 January 2021; and

(2) all aeroplanes with an MCTOM of more than 45 500 kg and first issued with an individual CofA on or after 1 January 2021."

Discussions:

STRAWMAN FOR ARINC PROJECT PAPER 680

- The ICAO GADSS CONOPS indicates that the ADT functionality is to be resilient to failures of the aircraft's electrical power, navigation, communication systems and human factors errors, as well.
- However, there is no definition for resilience / robustness to failure in the GADSS family documents. Therefore, a new definition should be crafted.
- Resilience is characteristic that assures a certain intended performance, despite system's failures, faults and malfunctions, and user's errors and violations. It is a measure of the system's susceptibility to failure (update from the 08/08 meeting).
- This characteristic may be achieved through certain mechanisms (e.g.: operational procedure) or techniques (e.g.: system design).
- This resilience is referred as being "as practical as possible". This idea is further expanded in the Appendix C table of the ICAO GADSS CONOPS document, where the level of resilience for certain scenarios is presented. As it can be observed, resilience is translated into system independence (which is a system design technique) to ensure that the location of the end of flight is always known.

2.5 Integrated ADT Requirements for Architecture Study

Figure 15 is an embedded excel file with the derived requirements set developed during the requirements analysis phase for use as a basis for the architectural study. The contents of this file are:

Tab 1: "ADT Minimum Requirements": these are the "shall" requirements. The table includes an identifier code, the requirements source and reference within that source, the textual requirement and any associated notes, a notional (non-binding) allocation to the high functional blocks and architecture components as described in appendix B and editor notes on the derivation or intent of the requirement.

Tab 2: "ADT Recommendations": "These are the "should" requirements. The structure of this table follows that of the "ADT Minimum Requirements" table.

Tab 3: "Scenario Table" holistic distress triggering scenarios to cover a range of distress conditions, in the requirements tabs (ADT Minimum Requirements and ADT Recommendations tabs) this table is referred to as "table XXXX". The canonical ED-237 scenarios are also presented for cross reference in this tab.

Tab 4: Auxiliary Figures: reference figures from GADSS CONOPS and ARINC GAT Architectural framework

Tab 5: ICAO CONOPS Fig. E: GADSS CONOPS Entity/information flow figure for reference



Figure 15 SAI GAT Architecture Study Requirements Tables_REV_NEW.xls (embedded file)

Some significant aspects of these requirements include

STRAWMAN FOR ARINC PROJECT PAPER 680

- 1.) Airborne Systems Reliability (Req 0.1)
- 2.) Position and time accuracy (Req 2.3, 2.5)
- 3.) Ground Inputs (Opt 1.6)
- 4.) End-to-End Availability, Integrity and Continuity (OPT 0.4, OPT 0.5. OPT 0.6)
- 5.) The scenario set.

3.0 Autonomous Distress Tracking (ADT) Architecture Study

3.1 Architecture Study Introduction

3.1.1 Architecture Overview

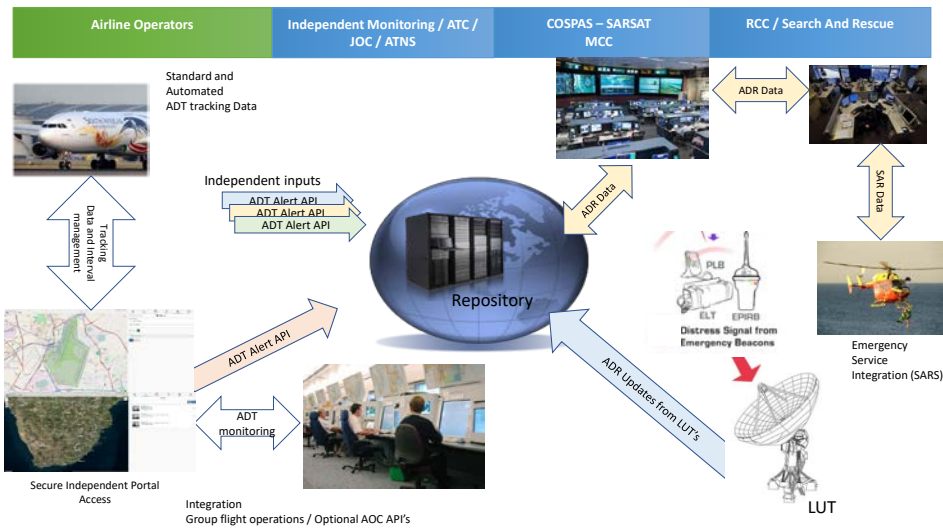

Figure 16: Illustration of Distress Tacking Data Flows to and from ICAO Data Repository

3.1.2 An ADT Architectural Framework

ADT Parts & Functions



Figure 17 ADT Components and Functions for Study Architecture Framework

ADT Parts & Functions

ADT Functional Block Diagram

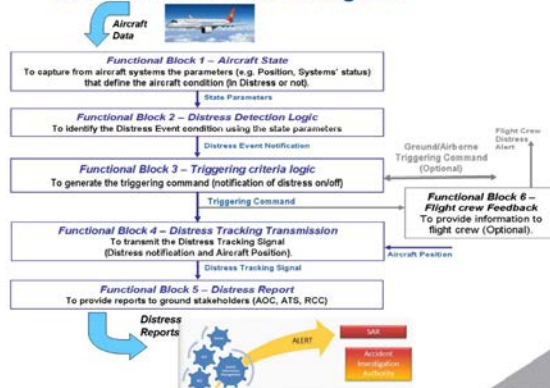

STRAWMAN FOR ARINC PROJECT PAPER 680

Figure 18 ADT Functional Block Definition for Study Architecture Framework

3.2 Automatic Dependent Surveillance – Broadcast (ADS-B) Architecture Study

3.2.1 Description of Architecture

Automatic Dependent Surveillance – Broadcast (ADS-B) Out (aka Extended Squitter) is a surveillance function which has been installed on all commercial air transport airplanes since the 2004 timeframe. ADS-B transmits aircraft data, including aircraft identification, horizontal position, altitude, velocity, and other parameters. Since the release of the RTCA DO-260 ADS-B Minimum Operational Performance Standards (MOPS) in 2000, there have been two revisions to the MOPS: DO-260A (in 2003) and DO-260B (in 2009). Some Air Navigation Service Providers (ANSPs) (e.g. NavCanada, AirServices Australia and certain ANSPs in Southeast Asia) have implemented ground ATC systems to track aircraft that meet any version of DO-260. The U.S. Federal Aviation Administration (FAA) has mandated that all aircraft (forward-fit and retrofit) be equipped with DO-260B compliant ADS-B Out functionality by Jan. 1, 2020. The European Union has mandated that air transport aircraft (forward-fit and retrofit) be equipped with DO-260B compliant ADS-B Out functionality by June 7, 2020.

Note: Europe is considering moving the retrofit date for DO-260B ADS-B Out from 2020 to 2025. However, many air transport aircraft delivered after 2004 already have DO-260 ADS-B out capability.

Other regions of the world have already mandated, or are in the process of mandating, ADS-B Out. Therefore, it is expected that a significant number of air transport aircraft worldwide will have ADS-B Out functionality installed by 2020.

From an air transport aircraft installation perspective, the ADS-B Out function resides in the same Line Replaceable Unit (LRU) (e.g. a standalone Air Traffic Control (ATC) transponder, an Integrated Surveillance System Processor Unit (ISSPU), a T2CAS unit, or a T3CAS unit), that contains the ATC transponder function. Each airplane has (2) ADS-B Out systems installed with one system being selected and active at any given time while the other ADS-B Out system is in standby mode (aka hot-spare). Each ADS-B Out system receives specific aircraft data parameters from other aircraft systems and alternately transmits the data in ADS-B Out registers in 1090 MHz Extended Squitter (ES) messages via the top and bottom ATC antennas (i.e. the ADS-B messages are transmitted out the top antenna, and then the bottom antenna). Air Traffic Services (aka Air Navigation Service Providers (ANSPs) which have ground-based ADS-B receiving stations (e.g. the FAA's network of ADS-B stations) receive the transmitted ADS-B data and provide the data to ATS automation for use in aircraft separation services.

In addition, *Aireon* has developed a Space-Based ADS-B receive capability which will provide worldwide ADS-B aircraft tracking services that can be interfaced to any Service Provider (e.g. ANSP/ATS Unit, FlightAware, or SITAonair). Figure 19 provides a general overview of *Aireon's* Space-Based ADS-B Network, which serves as a reference architecture for any given Space-Based ADS-B Network.

STRAWMAN FOR ARINC PROJECT PAPER 680

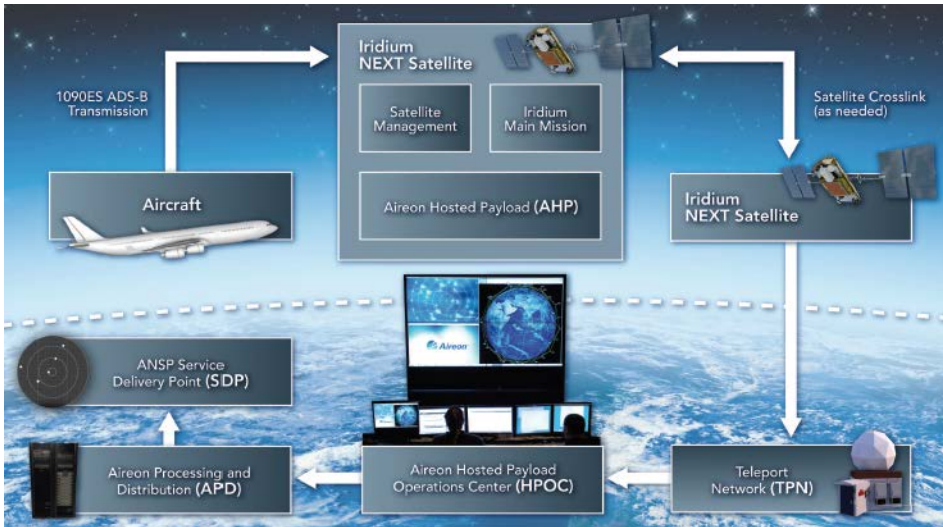

Figure 19 Space-Based ADS-B Network

Figure 20 provides an end-to-end architecture overview of the ADS-B Architecture for Distress Tracking.

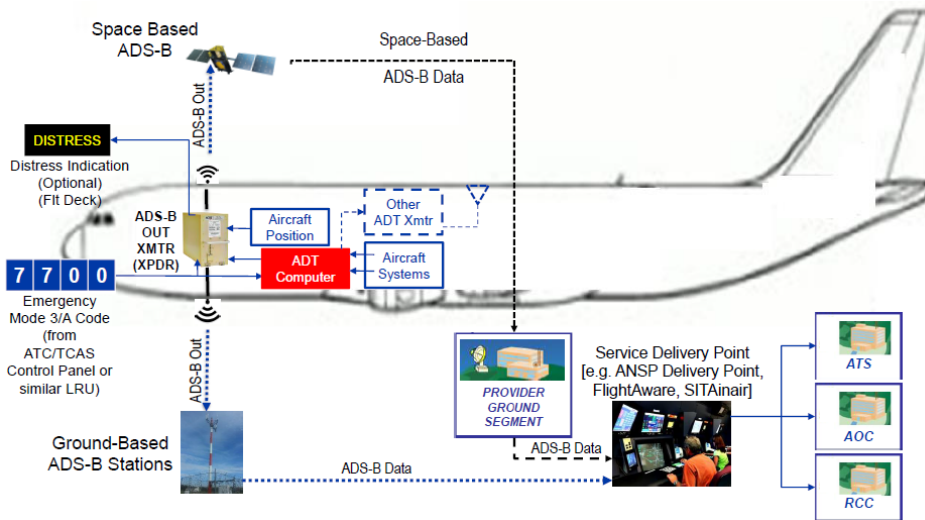

Figure 20 ADS-B Architecture for Distress Tracking (Example)

STRAWMAN FOR ARINC PROJECT PAPER 680

In this architecture, the ATC Transponder (shown as ADS-B OUT XMTR (XPDR) in Figure 20) is the Distress Tracking transmitter. The XPDR receives position data from an onboard position source(s). The position source will most likely be the Global Navigation Satellite System (GNSS) receiver (which is typically housed within a Multi-Mode Receiver (MMR) on many air transport aircraft). The GNSS provides worldwide, high accuracy, and high integrity horizontal position (latitude and longitude) data which is already provided to the XPDR to support the ADS-B Out function. The position data is transmitted in an ADS-B message (Airborne Position BDS register 05H) every 500 msec, alternating transmissions between the top ATC antenna and the bottom ATC antenna. Therefore, the ADS-B position data is transmitted from the top antenna once per second and from the bottom antenna once per second. In addition, the XPDR receives uncorrected barometric altitude data from an onboard air data source(s). The altitude data is transmitted in the same Airborne Position message (BDS register 05H) as the position data, and therefore, the altitude data is also transmitted from the top and bottom antennas once per second.

In the example architecture shown in Figure 20, the ADT Computer function contains the Distress Detection Logic and the Triggering Criteria Logic for determining whether an onboard distress event is occurring and whether a distress event has been cancelled. Alternatively, the ADT Computer function could be incorporated into the XPDR, but this is left to the implementer to decide whether this is feasible. For the purposes of this architecture study, the ADT Computer will be shown as a separate LRU.

STRAWMAN FOR ARINC PROJECT PAPER 680

3.2.1.1 Operational Description – General Emergency Alerting

When a distress event is active, a signal would be sent from the ADT Computer to the XPDR to indicate that a distress event is currently active. Current XPDRs would need to add logic to receive the distress event from the ADT Computer and set ADS-B messages as described below. The XPDR would register and transmit the distress event by encoding the following in EXISTING ADS-B messages (DO-260/260A/260B):

- 1) “Permanent Alert” in the Surveillance Status field of the “Airborne Position” message (BDS register 05H). This message is transmitted every 500 msec, alternating between the top ATC antenna and the bottom ATC antenna. Therefore, the distress event in the Emergency State field is transmitted from the top antenna every 1.0 second and from the bottom antenna every 1.0 second. Figure X shows the Surveillance Status field coding (bits 7-6) within the Airborne Position message (BDS register 05H). When the distress event is no longer active, the field will be set according to Figure 21.

Coding (Bits 7-6)		Meaning *
(Binary)	(Decimal)	
00	0	No Condition Information
01	1	Permanent Alert (Emergency Condition)
10	2	Temporary Alert (Change in Mode A code)
11	3	Special Position Identification (SPI)

* Note: Code 1 takes precedence over Codes 2 and 3. Code 2 takes precedence over Code 3.

Figure 21 . Surveillance Status Field of Airborne Position Message

- 2) “**General Emergency**” in the Emergency State field of the “Emergency/Priority Status” message (BDS register 61H – Subtype 1). This message is transmitted every 1.0 second, alternating between the top ATC antenna and the bottom ATC antenna. Therefore, the distress event in the Emergency State field is transmitted from the top antenna every 2.0 seconds and from the bottom antenna every 2.0 seconds. . . Figure 22 shows the Emergency State field coding (bits 11-9) within the Emergency/Priority Status message (BDS register 61H – Subtype 1).

Coding (Bits 11-9)		Meaning
(Binary)	(Decimal)	
000	0	No Emergency
001	1	General Emergency
010	2	Lifeguard/Medical Emergency
011	3	Minimum Fuel
100	4	No Communications
101	5	Unlawful Interference
110	6	Downed Aircraft*
111	7	Reserved

* Note: ‘6’ means “Downed Aircraft” in DO-260A/B. The value of ‘6’ is “Reserved” in DO-260.

STRAWMAN FOR ARINC PROJECT PAPER 680

Figure 22 . Emergency State Field of the Emergency/Priority Status Message

(BDS 61H Subtype 1)

These “Permanent Alert” and “General Emergency” codes are received by all ADS-B receivers within range (from terrestrial and Space-Based systems) and can signify a distress condition to ATS, AOCs, and RCCs that are subscribed to the ADS-B data from these systems. In fact, the FAA’s ATC automation systems already process the data within the Figure 10 Emergency State field (bits 9 through 11) in the Emergency/Priority Status message and will provide an ATC emergency alert if the field is set to General Emergency (001).

Several companies such as FlightAware and SITAonair will be connected to ADS-B sensor networks of their own, as well as to Space-Based ADS-B, and distribute the data with applications that are configurable to alert AOCs and/or RCCs to several common distress conditions (e.g. emergency Mode 3/A codes, sudden changes in altitude or speed, etc.). Additionally, Aireon will provide, upon customer requests, a service called Aircraft Locating and Emergency Response Tracking (ALERT) for contingency conditions. However, this service by itself is not designed to support ADT.

A Manual Distress Trigger capability in the flight deck could also allow the flight crew to manually activate a distress event. The XPDR is already connected to a flight deck control head (e.g. an ATC/TCAS control panel or similar LRU) where the Mode 3/A code (aka “squawk code”) is selected by the flight crew. When the Mode 3/A code is set to the General Emergency code (7700), then the XPDR transmits the Emergency State field in the Emergency/Priority Status message (BDS register 61H, subtype 1) with an encoding of “1” (001) which represents a General Emergency.

In addition, the XPDR could also provide an input to an optional Flight Deck “DISTRESS” indicator (e.g. annunciator light or crew alerting message) to alert the flight crew when a distress signal (Emergency State Field = “1” (001)) is being transmitted by the XPDR. However, this type of indication is dependent upon the aircraft implementation, and should take into account human factors considerations and the overall flight deck philosophy for that aircraft platform.

Note that with the ADS-B architecture, there is no “uplink” function that would enable the ground to initiate an airborne distress signal.

3.2.1.2 Operational Description – Potential Enhanced Alerting Features

It is important to emphasize that the ADS-B Out messages in Figure X and Figure 10 are EXISTING messages that are currently transmitted by all DO-260/DO-260A/DO-260B compliant XPDRs. Current XPDRs would need to add logic to receive the distress event from the ADT Computer and set the ADS-B messages accordingly.

These existing messages provide a simple, basic Emergency Alert from the aircraft. To send additional, lower-level ADT alert information would require additional ADS-B Out data fields or data messages be assigned, and would require changes to the existing DO-260B industry standard. The Figure 10 Emergency/Priority Status field is limited by the use of Subtype code 1. In order to transmit more detailed information regarding ADT Computer-sourced

STRAWMAN FOR ARINC PROJECT PAPER 680

information, a new subtype code(s) could be assigned. Per DO-260B, there are 5 unassigned Subtypes available (3 through 7). One (or more) new message matrices could be defined to precisely identify the reason for the ADT distress transmission.

Coding (Bits 11-9)		Meaning
(Binary)	(Decimal)	
000	0	No ADT Activation
001	1	Automatic ADT Activation
010	2	Manual ADT Activation
011	3	See below*
100	4	See below*
101	5	See below*
110	6	ADT Condition Cancelled/Cleared
111	7	Reserved

Figure 11 . Examples of Potential New Subtype Codes to Support Enhanced ADT Alerting Features

*Messages such as Unusual Attitude, Unusual Altitude, Unusual Airspeed, Impact Imminent, Loss of Primary Electrical Power, EGPWC Warning, etc. could be used here. The possibilities are limited by the functionality of the ADT Computer. If there are multiple causes for the ADT activation, the ADT Computer could cycle the coding bits from, for instance 'Automatic ADT Activation / Unusual Attitude / Automatic ADT Activation / Unusual Attitude' and so on. When the alert condition is corrected, bits 110 'ADT Condition Cancelled/Cleared' is transmitted. Note also that the Permanent Alert state in BDS Register 05H and the General Emergency state in Register 61H Subtype 1 would also need to be cleared.

Defining the transmission to be of ADT origin and providing the actuation type and cause could provide investigators with immediate knowledge for the reason of the aircraft emergency. This type of information may be useful to the AOC, RCC, or SAR, and would also be beneficial in the event that the FDR could not be recovered.

3.2.2 ADS-B Architecture Mapped to the Architecture Frame Work

Figure 23 is the ADT Functional Block Diagram. It explains each of the ADT system's functions and their interconnections.

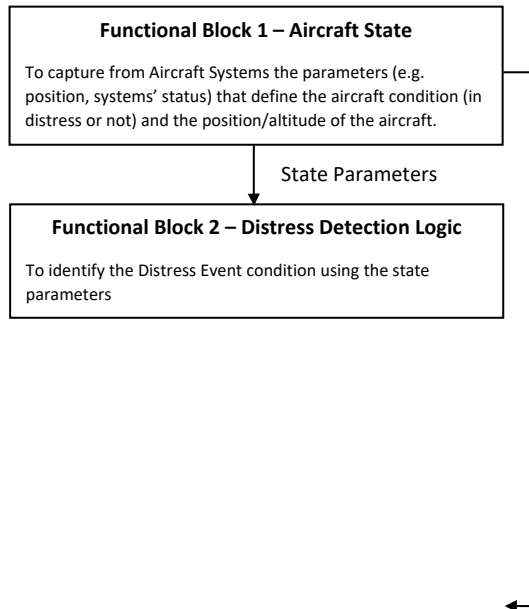

STRAWMAN FOR ARINC PROJECT PAPER 680

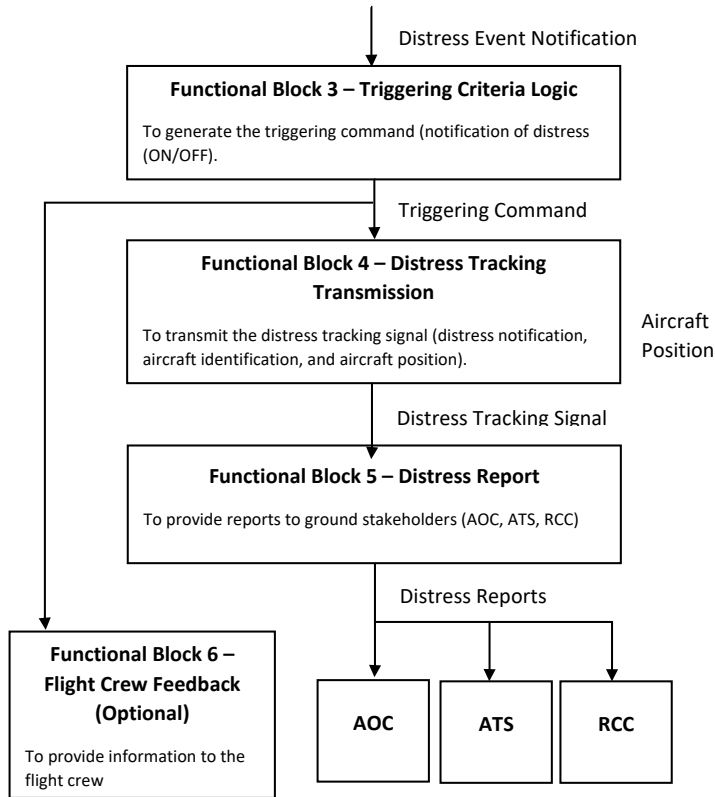

Figure 23 . ADT Functional Block Diagram

Figure 24 is the ADS-B Implementation Architecture that maps to each of the ADT system functional blocks (Functional Blocks 1 through 6) of the ADT Functional Block Diagram (Figure 23).

STRAWMAN FOR ARINC PROJECT PAPER 680

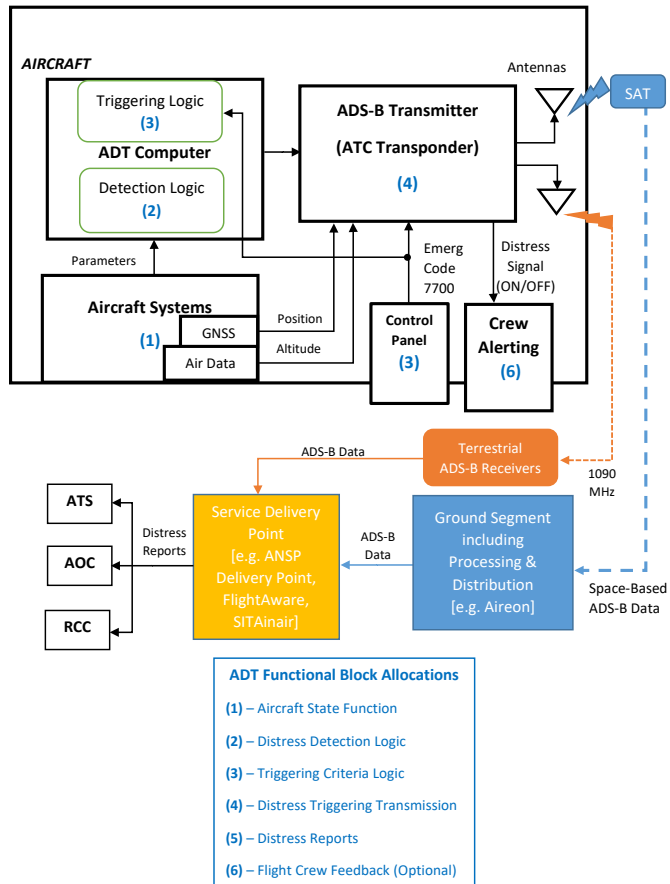

Figure 24. ADS-B Implementation Architecture

The ADT Triggering Logic (3) will generate a trigger event based on either:

- An automatic trigger based on the Detection Logic (2) being satisfied, or
- A manual trigger as set by the flight crew setting a XPDR Mode A code of '7700'

The ATC Transponder will transmit a distress signal via both top and bottom ATC antennas, along with the aircraft's identification, horizontal position, and altitude. This data, which is contained within ADS-B Out messages, can be received by any ADS-B receiver (including terrestrial ADS-B receivers as well as Space-Based ADS-B Receivers).

STRAWMAN FOR ARINC PROJECT PAPER 680

3.2.2.1 Key Architecture Assumptions and Dependencies

The ADS-B architecture has the following specific dependencies:

1. The aircraft ATC Transponders must be capable of transmitting ADS-B messages that meet the minimum operational performance standards (MOPS) of RTCA DO-260, DO-260A, or DO-260B.
2. In order to provide full-time, global ADS-B coverage, the Iridium Next satellites that carry the Aireon Hosted Payload and Main Mission L-Band antenna must be deployed. The current schedule for completing deployment of these satellites is July 2018.
3. The Aireon Ground-Based Network must be completed to the extent that high-integrity ADS-B data can be distributed to users of the data (e.g. FlightAware). The current schedule for completing the Aireon network that supports this level of functionality is July 2018.
4. FlightAware must be able to consume the Aireon ADS-B data and make it available to users of the data. FlightAware is currently receiving Aireon ADS-B data and performing beta testing. FlightAware is scheduled to provide Normal Tracking services by July 2018 and will provide ADT services by December 2018.
5. SITAonair currently provides Normal tracking using SATCOM and ACARS position reports. SITAonair plans on receiving Space-Based ADS-B data from FlightAware for use in Normal tracking services by July 2018 and for ADT services by December 2018.

3.2.2.2 Key Airplane Infrastructure Support and Required Changes

Key Airplane Infrastructure Support

The aircraft must be capable of transmitting ADS-B messages that meet the requirements of RTCA DO-260, DO-260A, or DO-260B MOPS. In addition, the ATC transponder must have the ability to receive specific data parameters from qualified systems. Horizontal position (latitude and longitude), along with position accuracy and integrity parameters, must be supplied by a qualified position source (e.g. GNSS). In addition, data containing aircraft identification (Flight ID) and altitude data (uncorrected barometric altitude) must be received and transmitted by the ATC transponder. All air transport aircraft delivered after approximately 2004 meet the above requirements. For aircraft that were delivered prior to 2004, there are aircraft service bulletins available to provide this functionality. Many operators have already purchased service bulletins and implemented the necessary aircraft changes in order to meet regulatory ADS-B mandates.

Required Changes

The aircraft must be updated as follows:

STRAWMAN FOR ARINC PROJECT PAPER 680

- Add an ADT Computer that provides the Detection and Triggering logic as outlined in Figure 23 and Figure 24.

Note: Alternatively, the Detection and Triggering logic could be added to the ATC Transponder LRU.

- Add wiring to connect the ADT Computer to the required aircraft systems to receive necessary data parameters
- Add wiring to connect the ADT Computer to the ATC Transponder so that a "Trigger ON/OFF" can be sent from the ADT Computer to the ATC Transponder.

3.2.2.3 Key Network Infrastructure Support and Required Changes

Discussion of key network support and changes required to support architecture.

- Aireon Network - Mike
- FlightAware - Mark
- SITAonair - Paul

3.2.2.4 Key Ground Segment Support and Required Changes

Discussion of key ground segment support and changes required to support architecture.

- Aireon Network - Mike
- FlightAware - Mark
- SITAonair - Paul

3.2.3 Compliance with Requirements

MORE WORK REQUIRED IN THIS SECTION

Evaluate the architectures support for the minimum and optional requirements described in Appendix B (minimum requirement set spreadsheet) and for the GADSS CONOPS (Ver 6.0) State of the Operator Approval Criteria Recommendations (section 3.2.10) using the matrices in Appendix C.

The ADS-B Architecture currently meets a significant number of the minimum requirements. Specifically, the following requirement categories are already met by the architecture:

- Location accuracy (within 6 NM)
- Reliability and integrity
- Manual distress activation input from the flightcrew
- Aircraft distress state to the flightcrew
- Aircraft position, identification, and time within required accuracies

STRAWMAN FOR ARINC PROJECT PAPER 680

The ADS-B Architecture's Space-based ADS-B capability, including the distribution of the ADS-B data to service points for use by end-users, will be available by December 2018 in order to validate end-to-end system performance.

Identify and provide textual/graphic descriptions and discussions of any major shortcomings and if and how they are expected to be addressed.

Provide textual/graphic descriptions and discussions of any additional capabilities or opportunities for improved distress capabilities and services not addressed in the requirements.

Identify and discuss requirements that potentially impose a significant cost or impact for the architecture and discuss where changes in requirements or alternative could potentially provide similar capabilities at a significantly reduced cost or impact.

Identify and discuss requirements where there is potential opportunity for the architecture to significantly exceed or improve on the required levels with minor impact and cost.

3.2.4 Support for Related Services and Capabilities

MORE WORK REQUIRED IN THIS SECTION

Provide textual/graphic descriptions and discussions of any additional capabilities or opportunities for improved distress capabilities and services not addressed in the requirements. In particular address support for

1. Normal tracking
2. Abnormal and potential distress tracking
3. Implications for timely recovery of flight data
4. Post Flight Localization and Recovery

3.3 ELT-DT Architecture Study

3.3.1 Description of ELT-DT Based Architecture

2.1.1.1 Introduction to Emergency Locator Transmitters

An Emergency Locator Transmitter (ELT) is defined as transmitter equipment which broadcasts distinctive signals on designated frequencies which are used to locate an aircraft and survivors after a crash.

An ELT may take any of the following forms:

- Automatic Fixed (ELT (AF)) - This type of ELT is intended to be permanently attached to the aircraft before and after a crash, to automatically activate upon a crash, and is designed to aid SAR teams in locating a crash site.
- Automatic Portable (ELT (AP)) - This type of ELT is intended to be rigidly attached to the aircraft before a crash, automatically activates upon a

STRAWMAN FOR ARINC PROJECT PAPER 680

crash, but is readily removable from the aircraft after a crash. If the ELT does not employ an integral antenna, the aircraft-mounted (external) antenna may be disconnected and an auxiliary antenna (stored on the ELT case) connected in its place. The ELT can be tethered to a survivor or a life raft. This type of ELT is intended to aid SAR teams in locating the crash site and/or survivor(s).

- Automatic Deployable (ELT (AD)) - This type of ELT is intended to be rigidly attached to the aircraft before a crash and automatically deploy when a crash occurs. This type of ELT also operates while floating in water and is intended to aid SAR teams in locating the crash site. The ELT(AD) may be either a stand-alone beacon or may be a part of an Automatic Deployable Flight Recorder.
- Survival (ELT (S)) - This type of ELT is intended to be removed from the aircraft after a crash and activated by survivors or automatically with the deployment of other survival equipment. There are two categories of ELT(S) Category A which is buoyant and designed to operate when floating in water and Category B which is not designed to operate when floating in water. This type of ELT is intended to aid SAR teams in locating survivor(s).
- Distress Tracking (ELT (DT)) - This type of ELT is designed to be activated prior to a crash upon detection of a distress condition by logic such as that defined by EUROCAE MASPS ED-237. This type of ELT is intended to provide information prior to the crash to aid in locating the crash site and may not be required to survive the impact.

The usage of ELTs are outlined in the ICAO Standard and Practices:

- In ICAO Annex 6, Part IIA, a Recommendation is made that all airplanes operated on extended flights over water and when operated on flights over designated land areas shall be equipped with an automatic ELT. There is an identical Recommendation in respect of certain Classes of helicopter when conducting overwater operations.
- ICAO Annex 10, Volume V requires that ELTs carried in compliance with the Standards of Annex 6, Parts I, II and III shall operate on both 406 MHz and 121.5 MHz. Although the SAR satellite systems are no longer able to use 121.5 MHz signals, this frequency is considered necessary to allow homing.
- All ELTs capable of transmitting on 406 MHz must be coded in accordance with ICAO Annex 10 and registered with the national agency responsible for initiating Search and Rescue or another nominated agency.

National regulations incorporate the certification of ELT's through the Technical Standard Order (TSO) process.

- TSO-c126b and ETSO-c126b define the requirements of ELTs for both USA and EU certifications respectively.
- The TSO and ETSO reference the standards RTCA DO-204a and EUROCAE ED-62a respectively; *MINIMUM OPERATIONAL*

STRAWMAN FOR ARINC PROJECT PAPER 680

PERFORMANCE SPECIFICATION FOR AIRCRAFT EMERGENCY LOCATOR TRANSMITTERS 406 MHz AND 121.5 MHz (OPTIONAL 243 MHz).

- These MOPS are current being revised and updated by RTCA SC-229 and EUROCAE WG-98 with expected publication by mid-year 2018.

All ELTs operate on the International Cospas-Sarsat System which is described in the next section. An ELT must be independently certified and approved for use on the Cospas-Sarsat system. This Type Certification requires testing at an approved test lab and then a subsequent review conducted by the technical officers of the Cospas-Sarsat organization. The Type Approval is required by the TSO and ETSO. The applicable standards are published by Cospas Sarsat and are updated annually:

- *C/S T.001 - SPECIFICATION FOR COSPAS-SARSAT 406 MHz DISTRESS BEACONS*
- *C/S T.007 - COSPAS-SARSAT 406 MHz DISTRESS BEACONS TYPE APPROVAL STANDARD*
- *C/S T.018 - SPECIFICATION FOR SECOND-GENERATION COSPAS-SARSAT 406-MHz DISTRESS BEACONS*
- *C/S T.021 - COSPAS-SARSAT SECOND GENERATION 406-MHz DISTRESS BEACON TYPE APPROVAL STANDARD*

3.3.1.2 COSPAS-SARSAT SYSTEM OVERVIEW

The International Cospas-Sarsat Program is a treaty-based, nonprofit, intergovernmental humanitarian cooperative of more than 40 nations and agencies dedicated to detecting and locating 406 MHz radio beacons activated from aircraft, vessels and by persons (e.g., hikers, skiers, remote workers) in distress, and forwarding this alert information to search-and-rescue (SAR) authorities that can take action for rescues.

The system utilizes a network of satellites that provide coverage anywhere on Earth. Distress alerts are detected, located and forwarded to over 200 countries and territories at no cost to the receiving government agencies. Cospas-Sarsat was conceived and initiated by the founding Party States of Canada, France, the United States, and the former Soviet Union in 1979.

406 MHz Distress Beacons: The family of 406 MHz Distress Beacons capable of being detected by the Cospas-Sarsat System include:

- Emergency Locator Transmitters (ELTs) for aviation use,
- Emergency Position Indicating Radio Beacons (EPIRBs) for maritime use
- Personal Locator Beacons (PLBs) .
- Some beacon models also can receive "return link messages" sent to them over the navigation channels of the Galileo satellite system.

STRAWMAN FOR ARINC PROJECT PAPER 680

- The first generation of beacons (FGB) currently in use are detected through the Doppler shift of the narrowband beacon frequency (406MHz) by the orbiting satellites.
- The second generation of beacons (SGB) being developed will be detected by the time delay of arrival of signals from a number of satellites and will use spread spectrum modulation.

Space Segment: The Cospas-Sarsat system Space Segment consists of :

- The distress-alert instruments are attached as secondary payloads to satellites that are being launched primarily for meteorological or navigation purposes.
- SAR signal repeaters (SARR) and SAR signal processors (SARP) aboard satellites;
- Satellites in polar low-altitude Earth orbit called LEOSARs;
- Satellites in geostationary Earth orbit called GEOSARs; and
- Satellites in medium-altitude Earth orbit called MEOSARs.

Ground Segment : The system consists of a Ground Segment that includes:

- Distress radio-beacons to be activated in a life-threatening emergency;
- Several satellite downlink receiving and signal processing ground stations called LUTs (local user terminals);
- The independent calculation of the location is made from measurements of the Doppler-effect-induced frequency differences and/or distance-dependent time-of-arrival seen in the distress signal at the LUT receiver.
- In addition, the inclusion of GNSS or Navigation Interface position data in the beacon message can be used to directly locate the distress signal.
- Mission control centers (MCC) that exchange, route and distribute the distress alert data (particularly beacon location data) provided by the LUTs.
- Rescue Coordination Centers (RCC) which receive the alert data and prosecute the rescue.

Data Distribution System: Cospas-Sarsat provides a robust Data Distribution System for distress alerts and consists of:

- A network of more than 30 mission control centres, operated by governments, and distributed world-wide;
- Built in redundancy of data distribution regions to collect, store, sort data.
- Communication links to global SAR authorities, which are tested on a monthly basis.

Further information on Cospas-Sarsat, the system and beacons can be found at <http://www.cospas-sarsat.int> .

3.3.1.3 The ELT in Autonomous Distress Tracking

STRAWMAN FOR ARINC PROJECT PAPER 680

Emergency beacons, and in particular ELTs, are specified and developed to operate when stationary or moving very slowly (walking, drifting). The use of an ELT operation in flight requires careful consideration of the transmission and message characteristics necessary to track an aircraft in flight.

The Distress Tracking ELT, ELT(DT), is a specific type of ELT designed to be activated prior to a crash and to function in compliance with the ICAO GADSS requirements for the Location of an aircraft in distress, aimed at establishing, to a reasonable extent, the location of an accident site within a 6 NM radius.

The ELT (DT) shall be armed/disarmed upon reception of the corresponding signal from the automatic triggering system. Once armed, it shall have the means to automatically activate the transmitter upon command from the automatic triggering system and radiate a signal through an antenna. ELT(DT) shall stop transmitting an alert signal and shall start transmit a cancellation signal only when the cancellation command is originating from the same mechanism that activated it

The key characteristics of the ELT(DT) are shown in Figure 25 and are centered around faster transmissions, GNSS position in the message, and crash survivability.

- The ELT(DT) may be activated automatically upon detection of a distress condition while in flight , activated manually, or activated from the ground (for example via the Galileo Return Link Service.
- The first transmission occurs within the first 5 seconds after activation.
- Subsequent transmissions occur every 5 seconds for the first 30 seconds of operation and then every 30 seconds thereafter.
- The ELT(DT) must operate at least 20 hours at the minimum specified operating temperature.
- The ELT (DT) requires the inclusion of a GNSS capability.
- The ELT(DT) is not required to have a homing signal (121.5 MHz) for on-site crash location.
- A regular ELT(DT) not expected to survive a crash, however, ..
- For an ELT(DT) specifically designed to survive a crash
 - The Beacon Hex ID is always that of an ELT(DT), that is it doesn't change after a crash
 - The device needs some sort of crash sensor as it is meant to change the Triggering Event Bits in the Rotating Field to indicate G-switch activation
 - The device is required to restart the transmission sequence after a crash (i.e. repeat the 6 bursts in the first 30 seconds)
 - The total required minimum duration of 406 MHz continuous operation is 24 hours (that is pre-crash added to post crash, so if the ELT(DT) was on for 5 hours before the crash it only has to do 19 hours post-crash)
- A combined ELT(DT) and ELT(AF) will meet the requirements of both devices independently.

STRAWMAN FOR ARINC PROJECT PAPER 680

Parameter	1 st Gen T.001 ELT	1 st Gen T.001 ELT(DT)	2 nd Gen T.018 ELT	2 nd T.018 ELT(DT)
406 Repetition Period	50 secs	5 secs for first 30 secs then 30 secs	5 secs for first 30 secs, then 30 secs for 30 min then 120 secs	5 secs for first 30 secs then 30 secs
Time to first transmission	Greater than 50 sec	Less than 5 sec	Less than 3 sec	Less than 3 sec
Bit Rate	400 bps +/- 1%	400 bps +/- 0.1%	300 bps +/- 1%	300 bps +/- 1%
Cancellation Message	No	Yes	Yes	Yes
Medium Term Stability Spec	Yes	No	No	No
Output Power (EIRP)	32 to 43 dBm	34 to 45 dBm	33 to 45 dBm	33 to 45 dBm
Transmission Scheme	Narrowband	Narrowband	Spread Spectrum	Spread Spectrum
Modulation Scheme	B-phase L	B-phase L	OQPSK	OQPSK
Modulation Rise and Fall Times	150 +/- 100 us	100 +/- 50 us	Less than 15 us	Less than 15 us
Thermal Shock	30°C	50°C	50°C	50°C
Operating Lifetime	24 Hours	20 Hours	24 Hours	20 Hours
Internal Navigation Receiver	Optional	Mandatory	Optional	Mandatory
First transmission with position	10 minutes	5 seconds	2 minutes	3 seconds
Position Updates	Between every 15 to 60 minutes	Before every burst (every 5 or 30 sec)	Before every burst for first 30 minutes then between 15 to 60 min	Before every burst (every 5 or 30 sec)
Position	2D (lat & long)	3D (lat, long & height)	3D (lat, long & height)	3D (lat, long & height)
Coded Digital Message	Various	Special ELT(DT)	Standard	Special ELT(DT)
Digital Message Length	144 Bits	144 Bits	300 Bits	300 Bits
Error Correction	BCH – 2 Bits max	BCH – 2 Bits max	BCH – 6 Bits max	BCH – 6 Bits max
Homming Signal (FAA/EASA)	Required	Not required	Required	Not required

Figure 25 . ELT(DT) Performance Summary

3.3.1.4 ELT(DT) End to End Architecture – Anatomy of a Rescue

The structure of the Cospas-Sarsat System have been presented and the unique performance characteristics of an ELT(DT) have been outlined. The same C/S Space Segment, Ground Segment, and SAR Routing are utilized with an ELT(DT) as with any other type of beacon. The inclusion of the GADSS Conops 6.0 Swim Lane for an ELT(DT) completes the scenario with data management, agency alerting, and coordination of the rescue.

For illustration, Figure 26 shows a pictorial of a rescue based on the MEOSAR satellite and ground segment. Figure 27 shows the Swim Lane for an ELT(DT) .

- An Alert is triggered and the ELT(DT) transmits the emergency message to the satellites on 406MHz.
- The message is then downlinked via an L-band transmission to the local user terminals, or in this case the MEOLUT.
- The ELT(DT) message is demodulated and decoded and then forwarded automatically to the appropriate MCC.
- The MCC routes the alert to the ATSU.
- The MCC then routes the alert to the RCC.
- The RCC validates the alert and prepares to deploy assets.
- The flow of the swim lane shows the subsequent flow of communication and actions between the RCC, the ATSU, and the Airline Operator.
- The process proceeds until the rescue is prosecuted or cancelled.

STRAWMAN FOR ARINC PROJECT PAPER 680

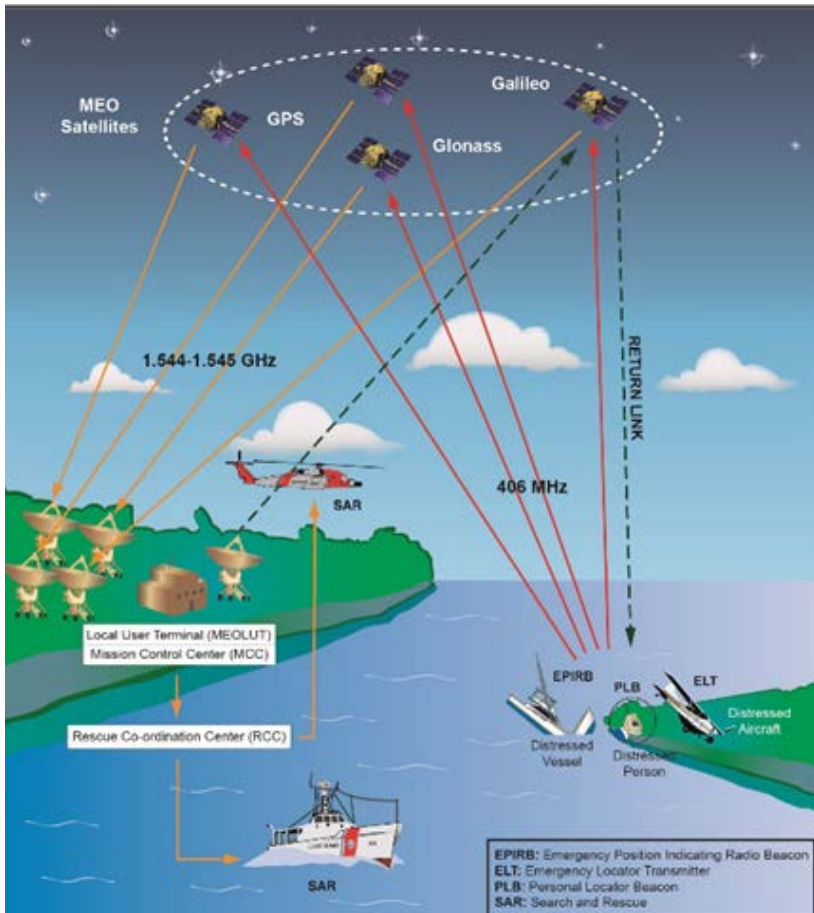

Figure 26. Cospas-Sarsat Rescue System

STRAWMAN FOR ARINC PROJECT PAPER 680

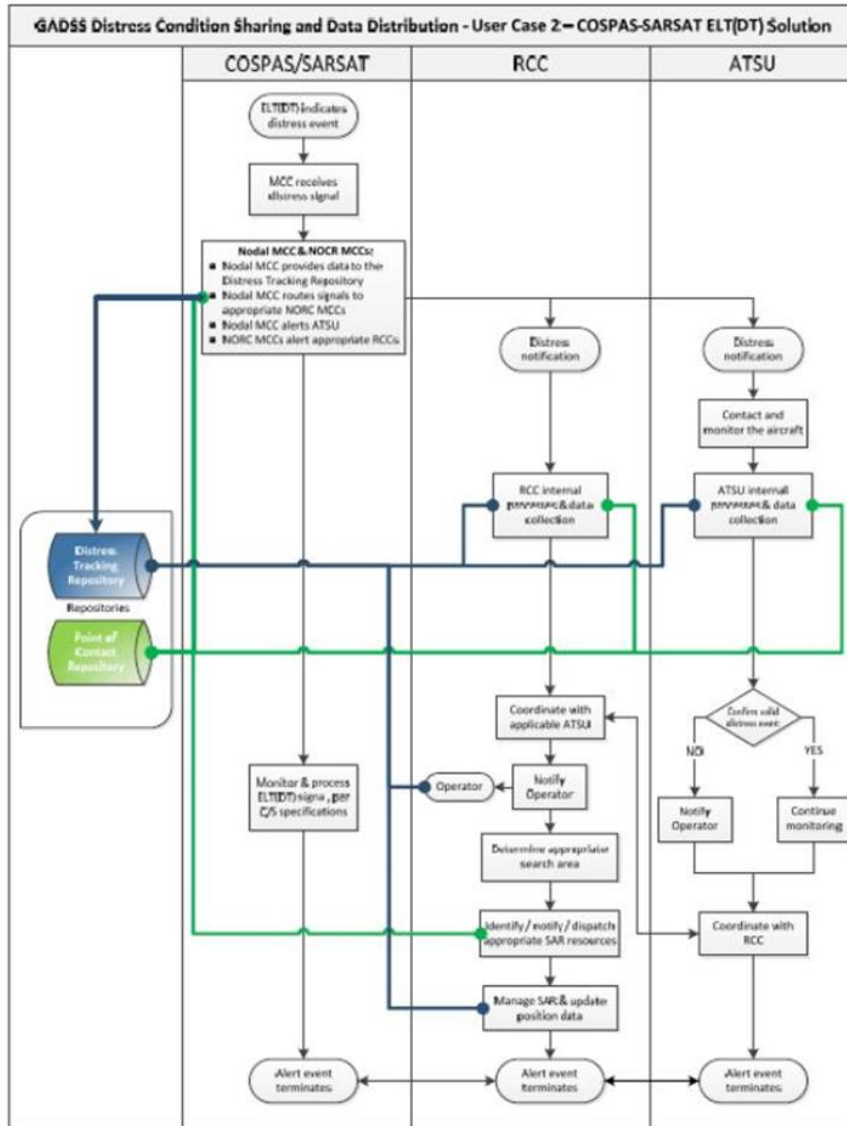

Figure 27. GADSS Conops 6.0 ELT(DT) Swim Lane

3.3.2 ELT-DT based Architecture Mapped to the Architecture Frame Work

Key components and capabilities of the ELT(DT) architecture are mapped to the architecture framework described in Figure 28). Below is a discussion, in terms of architecture framework components, of the architectures' functionality that supports the component.

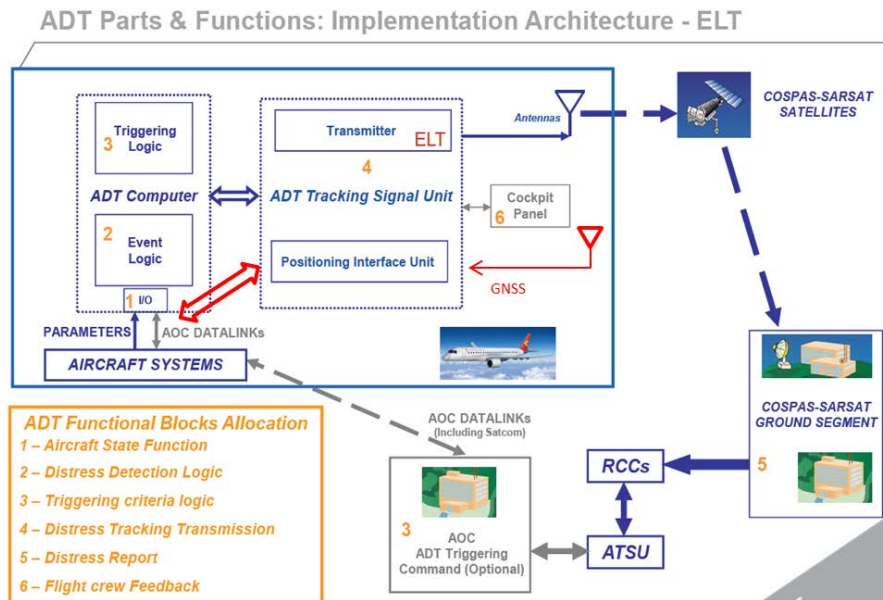

Figure 28. ELT-DT Mapped to ADT Functional Blocks

Functional Block 1 – Aircraft State : To capture from Aircraft Systems the parameters (e.g. position, systems' status) that define the aircraft condition (in distress or not) and the position/altitude of the aircraft.

Functional Block 2 – Distress Detection Logic : To identify the Distress Event condition using the state parameters.

It is currently envisioned that the Distress Detection Logic (DDL) would be functionally separate from the ELT(DT) unit. In this configuration, the DDL would be a common element across all architectures. As part of the Automatic Distress Tracking (ADT) computer, the DDL monitors state parameter input from Function Block 1 and filters the data to assure integrity, observes trends in aircraft state, applies control limits on inputs, applies abnormal/distress algorithms, and identifies the potential for an alert condition.

Functional Block 3 – Triggering Criteria Logic

STRAWMAN FOR ARINC PROJECT PAPER 680

To generate the triggering command (notification of distress (ON/OFF)).

The Triggering Criteria Logic takes the summary data and potential alert state from the Distress Detection Logic and applies the final algorithm to determine whether the alert state is an abnormal condition or truly a distress condition. If a distress condition, the TCL initiates the distress trigger to the Distress Tracking Transmission, i.e. the ELT(DT).

Functional Block 4 – Distress Tracking Transmission

To transmit the distress tracking signal (distress notification, aircraft identification, and aircraft position).

This functional block is the ELT(DT) as defined in the ED-62B MOPS and the Cospas Sarsat documents. Note the inclusion of the position source (GNSS) directly being a part of the ELT(DT) system. In addition, aircraft state parameters can be interfaced directly to the ELT(DT). An ELT (DT), as per the MOPS, shall incorporate an interface to aircraft systems for the following functions (either as separate electrical discrete or coded on a digital bus).

- a) Receive a triggering command from the automatic triggering system.
- b) Provide an indication that an automatic trigger was received.
- c) Receive a cancellation command from the automatic triggering system. Loss of the automatic triggering command indication shall not be interpreted as a cancellation command.
- d) Provide an indication that an automatic trigger cancellation command was received.
- e) Continuously monitor the triggering command communications connection between the automatic triggering system and ELT. If that connection is lost while the ELT is armed the ELT shall be activated.
- f) Receive arm/disarm commands for the automatic triggering system so that normal post-flight shutdown of the automatic triggering system will not cause the ELT to activate and that pre-flight activation of the ELT cannot occur.
- g) Remote control and monitoring functions as described in the MOPS.
- h) Provide an indication that a manually activated trigger was cancelled.

In addition to the required functions above, an ELT (DT) may include interfaces for one or more of the following optional functions.

- a) Receive GNSS information from aircraft systems.
- b) Receive parametric data from the aircraft.
- c) Receive information about criteria that triggered automatic activation.
- d) Indication of availability of and/or connection to external power.
- e) Communications with aircraft maintenance systems to initiate self-tests and provide results to the cockpit.

Functional Block 5 – Distress Report To provide reports to ground stakeholders (AOC, ATS, RCC).

As previously described, the Cospas-Sarsat Space and Ground segment are in place and working in Search and Rescue operations today. Notification

STRAWMAN FOR ARINC PROJECT PAPER 680

occurs automatically from the MCC to the RCC, and subsequently to the ATS. ATS notifies the operator.

Functional Block 6 – Flight Crew Feedback (Optional)

To provide information to the flight crew. The ELT(DT) has a cockpit indicator which is defined in the MOPS ED-62B. A Remote Control and Monitoring System of an Automatic ELT shall have the following functions:

- MANUAL ON: ELT unit manually activated.
- ARMED: ELT unit enabled such that activation will occur in response to an activation input (for example, crash sensor, water switch, triggering logic or a remote manual activation)
- RESET: ELT unit deactivated and return to “ARMED”. The control must have a provision to prevent inadvertent reset. In the case of ELT(DT), this function shall only reset the manual activations and automatic activations due to the crash sensor, when installed, but not the activations resulting from an automatic distress tracking logic,
- SELF-TEST: ELT unit Self-Test function provided (refer to §2.8) and optionally including GNSS self-test functionality.
- CANCELLATION: ELT unit transmits a cancellation sequence and then returns to the “ARMED” mode. (T.018 ELT(AD), ELT(AP) and ELT(S) ELTs only) (Note that T.001 ELT(DT)s and T.018 ELT(AF)s and ELT(DT)s are not required to have a separate Cancellation Function but are required to transmit a cancellation sequence when RESET)
 - The control must have a provision to prevent inadvertent cancellation, shall not be combined with the “MANUAL ON” function and shall require two simple and independent actions to enable it.
- REMOTE INDICATION and MONITORING
 - Inform the crew in the cockpit if the ELT is activated
 - Inform the crew in the cockpit the outcome of a self-test
 - Inform the crew in the cockpit when the ELT AD is deployed
 - The monitoring system can be independent of the Remote Control
 - The indicators and remote control should be continuously powered during aircraft operation. For this purpose, the indicators and remote control may use either a dedicated power source or an alternate power source (e.g., the aircraft power source).

Fault Tolerance: No combination of short or open circuits between the remote control, indicators, associated wiring and the airframe shall inhibit the ELT unit from being automatically activated or deactivated once the ELT unit has been activated.

Key assumptions and dependencies for the architecture.

ELT(DT) Ground Segment processing of new message structure is in place.

STRAWMAN FOR ARINC PROJECT PAPER 680

Key Assumptions and Dependencies for the Architecture.

The ELT(DT) must meet the requirements of TSO-c126C (expected 3Q 2018).

The ELT(DT) must meet the specifications of the MOPS DO-204B (ED- which is under development and expected by 2Q 2018).

The ELT(DT) must meet the specifications and obtain type approval under Cospas-Sarsat.

An ELT(DT) can be tested and certified today, however, Cospas-Sarsat may withhold the Type Certification until the ground service ready.

Key Airplane Infrastructure support and changes required to support architecture.

The ELT(DT) must comply with the Cospas-Sarsat specifications, and therefore must include an independent GNSS position source. This has implications that a separate GNSS antenna be installed on the aircraft.

The ELT(DT) must comply with the Cospas-Sarsat specifications, and therefore must operate a minimum 20 hours operation under its own independent power, and therefore has implications for battery size, versus other technologies.

Combination ELT LRUs, ELT(DT) and ELT(AF) have implications for battery size, versus other technologies. Such an LRU would need to operate for 20 hours as an ELT(DT)

Cancellation signal from the cockpit is required; hence cockpit hardware switch or interface to the ICAS is needed. This can be accomplished by using the RESET function.

Key Network support and changes required to support architecture.

Tracking data is being fed directly to the RCC, there is no Data Repository.

Key ground segment support and changes required to support architecture.

ELT(DT) Ground Segment LUT processing of new message structure is not in place until early 2019.

STRAWMAN FOR ARINC PROJECT PAPER 680

3.3.3 Compliance with Requirements

Evaluate the architectures support for the minimum and optional requirements described in Appendix B (minimum requirement set spreadsheet) and for the GADSS CONOPS (Ver 6.0) State of the Operator Approval Criteria Recommendations (section 3.2.10) using the matrices in Appendix C.

Identify and provide textual/graphic descriptions and discussions of any major shortcomings and if and how they are expected to be addressed.

Provide textual/graphic descriptions and discussions of any additional capabilities or opportunities for improved distress capabilities and services not addressed in the requirements.

Identify and discuss requirements that potentially impose a significant cost or impact for the architecture and discuss where changes in requirements or alternative could potentially provide similar capabilities at a significantly reduced cost or impact.

Identify and discuss requirements where there is potential opportunity for the architecture to significantly exceed or improve on the required levels with minor impact and cost.

Commented [TP9]: Use EXCEL Compliance matrix. Appendix B, C.

Notes in the spreadsheet can end up in this section with descriptions, pictures, examples of industry products.

I need requirements V2

Commented [TP10]: Are particular requirements which drive significant cost and impact. Are there alternative requirements which can be refocused to provide similar capabilities.

Commented [TP11]: Can there be better requirements which result in better performance and lower cost. A sensitivity assessment of architecture vs cost/performance.

3.3.4 Support for Related Services and Capabilities

Provide textual/graphic descriptions and discussions of any additional capabilities or opportunities for improved distress capabilities and services not addressed in the requirements. In particular address support for

1. Normal tracking:
 - a. The Cospas-Sarsat infrastructure and bandwidth limitations are not setup to support normal flight tracking operations.
2. Abnormal and potential distress tracking
 - a. The ELT(DT) could be triggered with an "abnormal" bit code to transmit the advent of a distress to the RCC.
3. Implications for timely recovery of flight data
 - a. An ELT(DT) message structure is rigidly defined by Cospas-Sarsat, so there is little opportunity or data bandwidth to effect timely transmission of flight data prior to a crash.
4. Post Flight Localization and Recovery
 - a. An ELT(DT) which is designed to survive a crash holds the potential of post flight localization just as an ELT(AF) does currently.

3.4 Inmarsat Based SATCOM Architecture Study

3.4.1 Description of Architecture

Inmarsat's satellite communication network is a proprietary and secure communication facility fit for safety-of-life services. It is the only satellite communication service today which is certified to operate IMO's global maritime distress and safety system (GMDSS). Because GMDSS and GADSS require similar functionality, it is prudent to consider using the same network infrastructure for GADSS.

Inmarsat wholly owns and operates the entire system of systems, including all subsystems such as space vehicles, satellite access stations, network nodes and primary and backup space vehicle and network operations centres (SOC and NOC). The network has existing interfaces with rescue coordination centres (RCC) and supports distress alerting, distress communications and priority and pre-emption for safety-of-life communications.

To use this infrastructure for GADSS, functionality specific to aviation can be added to the system. Figure 29 shows the overall system architecture and GADSS flow diagram as published in ICAO Doc 10054. Figure 30 shows the Inmarsat implementation of this architecture.

The following elements and functions can be supported by an Inmarsat based solution:

- Data SatCom
- Voice SatCom
- Data rates
- Equipage
- Tracking capabilities.

Global aircraft tracking data can be derived from ADS-C position reports, the location information reporting function integral to the satellite data units (SDU) aboard the aircraft and normally used for network management purposes, and flight recorder data if streamed in real-time.

Inmarsat itself does not natively provide distress alert triggering. This is a function of an on-board unit and must therefore be provided by an avionics OEM. We note that Inmarsat does operate the GMDSS system, for which distress alerting and management functions are provided by the Inmarsat maritime terminal. In a similar fashion, GADSS capable terminals / SDU could be provided that implement GADSS compliant and additional distress functions.

In addition to this, Inmarsat can implement a distress detection and alert triggering function on the ground by automatically monitoring the aircraft location and available other vehicle telemetry, and trigger a distress alert if a predefined set of parameter values depart from their respective expected envelopes. Further information on triggering can be found in chapter [\[ADD REF HERE\]](#).

Once an alert is received on the ground, whether through GMDSS, GADSS or otherwise, the RCC in charge is notified and communication between SAR and the vehicle in distress is established. In case of an aircraft in distress, the air

Commented [CP12]: As a minimum requirement ED 237 shall be used to define parameters and associated triggers

STRAWMAN FOR ARINC PROJECT PAPER 680

traffic service unit (ATSU) in charge of the flight can also notified, along with the aircraft's operator.

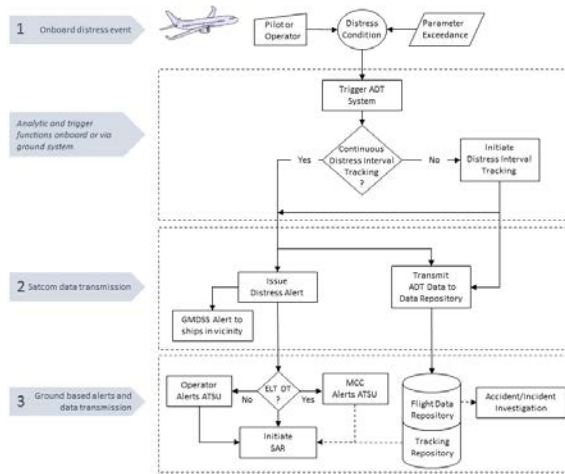
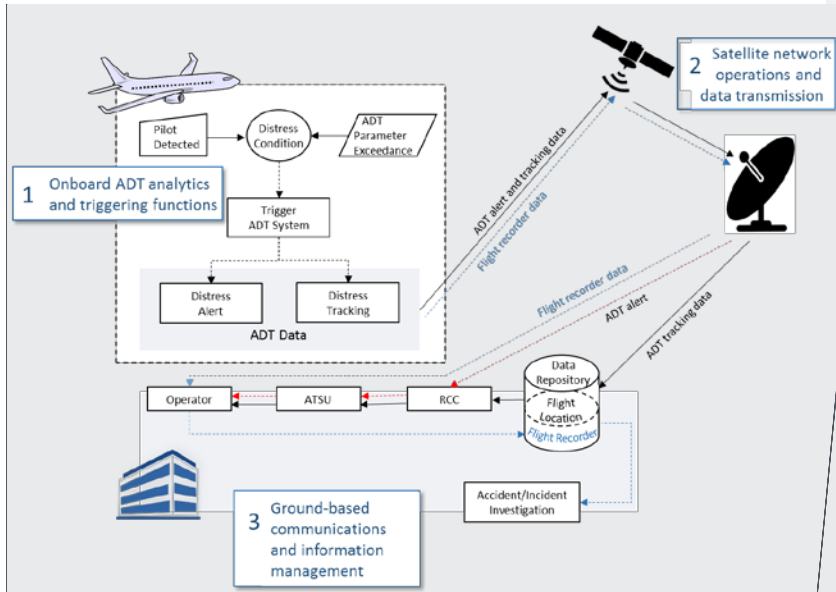

Figure 29: Overall ADT architecture as published within ICAO Doc 10054.

(To be harmonized between AEEC and ICAO Doc 10054)

STRAWMAN FOR ARINC PROJECT PAPER 680



Commented [CP13]: Not sure this diagram is in line with ConOps or the White Paper about ADT Data repository . Typically arrows between Operator/ ATSU/RCC/ Repository

Figure 30: Inmarsat GADSS implementation

Inmarsat already has repositories in place, as soon as the requirements are clear enough to design against, a service can be implemented with relative ease. Figure 2 shows a representative architecture of a possible Inmarsat implementation.

Repositories for Maritime... ADS-C

Paragraph on tracking data volume vs network capacity, network resource allocation

Robustness and potential architecture.

3.4.2 Architecture Mapped to the Architecture Frame Work (action CA)

Key components and capabilities mapped to the architecture framework described in Appendix A.

Discussion, in terms of architecture framework components, of the architectures' functionality that supports the component.

Discussion of key assumptions and dependencies for the architecture.

Discussion of key airplane infrastructure support and changes required to support architecture.

STRAWMAN FOR ARINC PROJECT PAPER 680

Discussion of key network support and changes required to support architecture.

Discussion of key ground segment support and changes required to support architecture.

3.4.3 Compliance with Requirements ref appendix c (action CA)

Evaluate the architectures support for the minimum and optional requirements described in Appendix B (minimum requirement set spreadsheet) and for the GADSS CONOPS (Ver 6.0) State of the Operator Approval Criteria Recommendations (section 3.2.10) using the matrices in Appendix C.

Identify and provide textual/graphic descriptions and discussions of any major shortcomings and if and how they are expected to be addressed.

Textual description of future enhancements

Provide textual/graphic descriptions and discussions of any additional capabilities or opportunities for improved distress capabilities and services not addressed in the requirements.

Identify and discuss requirements that potentially impose a significant cost or impact for the architecture and discuss where changes in requirements or alternative could potentially provide similar capabilities at a significantly reduced cost or impact.

Identify and discuss requirements where there is potential opportunity for the architecture to significantly exceed or improve on the required levels with minor impact and cost.

3.4.4 Support for Related Services and Capabilities

An Inmarsat based ADT system will provide opportunities beyond the anticipated minimum Distress Tracking functions so long as relevant data security requirements are met. The prevalence of installed Inmarsat systems (retrofit market), the significant available bandwidth, and the mature ground network operations allow an Inmarsat based architecture to provide several additional airline AOC/MOC advantages.

Encryption and Data Security Functions

Normal Tracking

By interfacing with various aircraft data buses an Inmarsat based ADT system can be functionally expanded to include "rich" normal tracking functions. Modifications to normal tracking features can be manually controlled through ground based systems to include reporting of any data available to the airborne ADT system. Airline operations can benefit from ground based GUI systems that allow modifications to reporting intervals, reported parameters, and two-way text communication between ground and aircraft. Additional autonomous tracking

Commented [CP14]: As discussed , Data Security requirements shall apply

STRAWMAN FOR ARINC PROJECT PAPER 680

modifications, such as interval changes based on various phases of flight can also be incorporated.

The large Inmarsat bandwidth provides opportunities to include significant aircraft state information in the payload of any normal tracking report. Trending and routine diagnostic information can be relayed in real-time with no interference to planned ADT detection and triggering. In the event that any ADT function is needed, normal tracking functions can be suspended.

Abnormal and Potential Distress Tracking

It is possible that the triggers for ADT tracking will be defined by a small set of conditions. It is also expected that these conditions will be unique to different airframes, types, models, operational modes, etc. By leveraging the onboard logic used for the ADT engine a different, more relaxed set of rules can be used to identify aircraft in an abnormal or potential distressed state.

Airline operations will benefit from a real-time understanding of an aircraft state that is not in distress, but that may warrant heightened tracking awareness. Additionally, the Inmarsat payload will allow for streaming of aircraft data, including the entire FDR, from a time before an alerting trigger is identified, to a time when the condition has been resolved.

Abnormal or potential distress tracking events can be defined and managed by an airline, independently of the ADT functions. Detection and triggering of abnormal states would remain an airline based responsibility and will not initiate any of the ADT functions.

As with normal aircraft tracking, ground based systems can be used to define and manage the triggers for abnormal tracking.

DAL considerations need to be addressed to properly manage the expected level 'D' ADT functions from any customer configurable level 'E' functions. REF SYSTEM

Commented [CP15]: The DAL, according to the chosen architecture will be Defined/linked to the System Safety Analysis (SSA)

Timely Recovery of Flight Data

Inmarsat-based ADT functions can provide a significant improvement for timely recovery of flight data and for post flight localization and recovery. Tracking an aircraft at 60 second intervals, or within a 6 NM radius will provide good post flight localization. But the Inmarsat space based network provides an opportunity for further improvement.

Latency through the Inmarsat network can effectively be measured in milliseconds. An aircraft that is nearing an end of flight situation can begin a stream of data off the aircraft such that the aircraft 4D position can be known in near real-time. If an antenna lock between aircraft and satellite is maintained during a descent, location of a downed aircraft will be known to a very high

STRAWMAN FOR ARINC PROJECT PAPER 680

degree of accuracy. In extremely unfavourable conditions an aircraft location would still be known within 1 km.

[...]

Inmarsat is capable of operating a Black Box in the Cloud service (BBiC), which offers a flight data repository located within its proprietary and secure network. The BBiC may count as a crash-protected memory because it is located away from the aircraft. It is therefore also instantly accessible, with access restricted to accident investigators, rescue coordination centres and related, authorized personnel. In the event of an alert, information pertaining to the flight in distress, especially relevant aircraft telemetry such as location, altitude, altitude change and emergency communication can be forwarded to the ATSU and RCC responsible for the distress flight, and broadcast to maritime vessels near it if the location is over water.

Commented [CP16]: Agree , but here we do not address A/C attitude which may impact the link with the satellite . Should this be part of Doc 10054 ?

Commented [CP17]: This § is linked to PFLR, not to ADT. I am questioning about its presence in this ADT report ? May be put this § in 2.1.4

Real-time, airborne system diagnostics

Using the high throughput capabilities of the Inmarsat network, MOC operations can have real-time access to data from the aircraft. The nature of an ADT system requires that aircraft state is continuously interpreted by monitoring various aircraft data busses. These same busses provide information that can be critical in diagnosing aircraft problems during a flight.

The bandwidth provided by Inmarsat makes this real-time diagnosis possible and economical. A system capable of providing the ADT functions can be expanded upon to provide this real-time data as a secondary function. In the event that ADT required functions are needed, any real-time diagnostic functions can be suspended in favour of aircraft distress tracking.

Trigger mechanism to complimentary third party system.

Some proposed ADT solutions may require an airborne third party system for activation. In a complimentary, dissimilar architecture, an Inmarsat based system as described above, could be used as an input to an ELT-DT or other system.

3.5 ADT with Iridium Transceiver Architecture Study

3.5.1 Description of Architecture

Autonomous distress tracking functionality is shown for aircraft equipped with Iridium transceiver for both block 1 constellation and high bandwidth Next constellation.

As part of the iridium ADT architecture study, these are the options presented and highlighted:

STRAWMAN FOR ARINC PROJECT PAPER 680

- Option A - Independent Event & trigger block (ie, ADT) and Iridium transceiver
- Option B - Integrated Event & trigger block (ADT) and Iridium transceiver and
- Option C - Separate Event & trigger block (ADT) and Iridium Transceiver with a builtin ADT capability (offering certain level of redundancy for the ADT function).

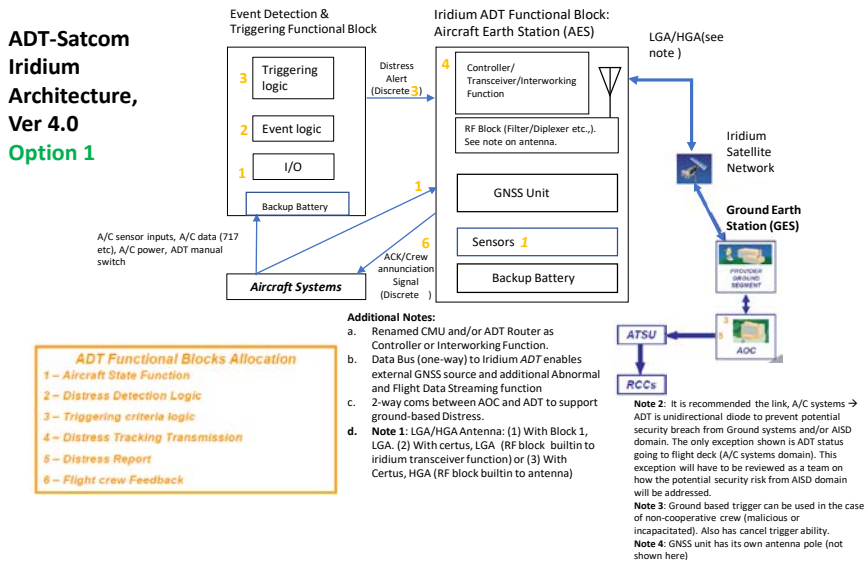

Figure 31: ADT SATCOM Iridium Architecture Option 1 (External Trigger Source)

STRAWMAN FOR ARINC PROJECT PAPER 680

ADT-Satcom
Iridium
Architecture,
Ver 4.0
Option 2

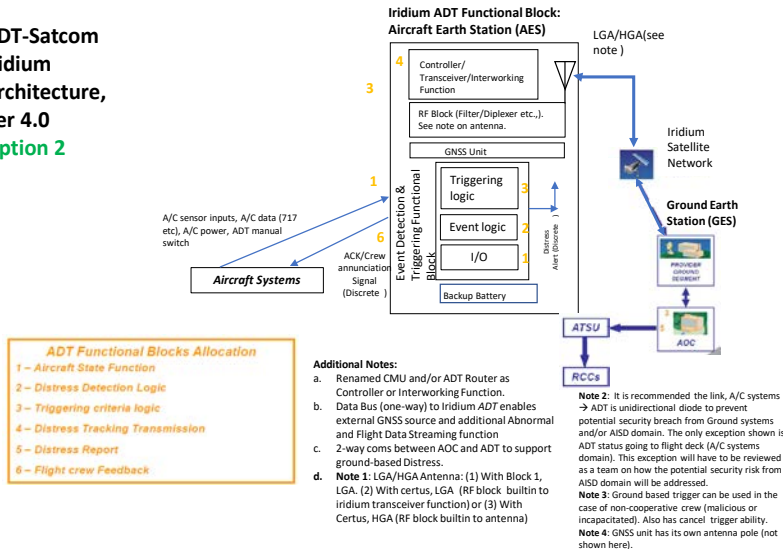

Figure 32: ADT SATCOM Iridium Architecture Option 2 (Internal Trigger Function)

STRAWMAN FOR ARINC PROJECT PAPER 680

ADT-Satcom
Iridium
Architecture, Ver
4.0
Option 3

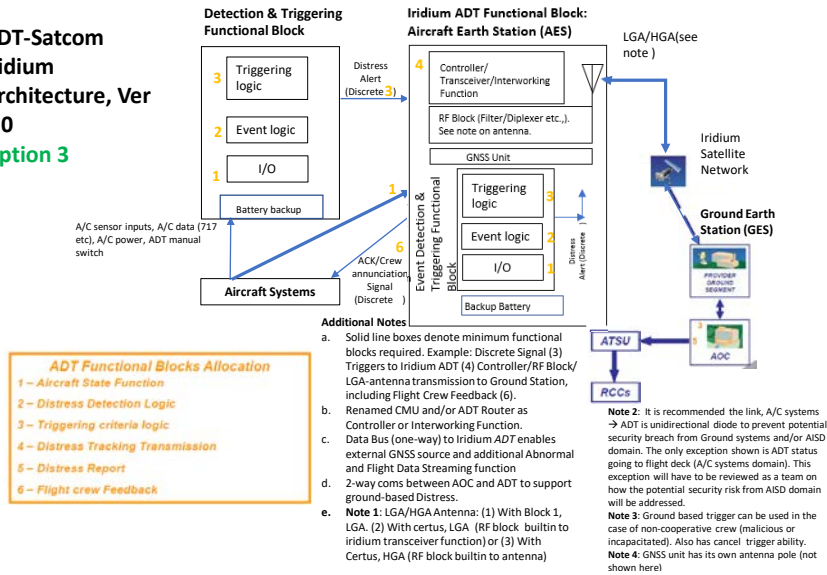

Figure 33: ADT SATCOM Iridium Architecture Option 3 (External and Internal Trigger Functions)

STRAWMAN FOR ARINC PROJECT PAPER 680

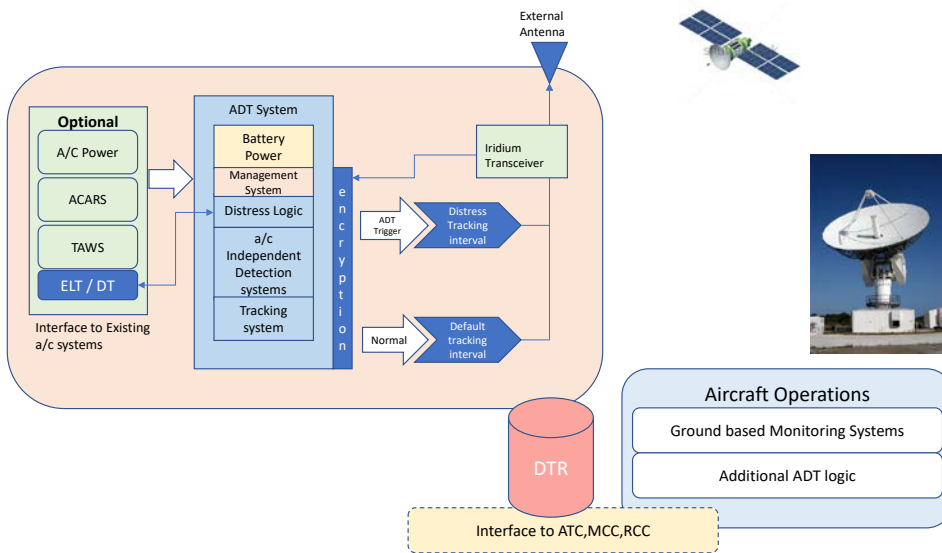

Figure 34: ADT SATCOM Iridium Architecture Option 4 (External and Internal Trigger Functions, Internal Iridium Transceiver Unit)

3.5.2 Architecture Mapped to the Architecture Frame Work

- Functional Block 1- Aircraft state --- Included in Architecture (Input to D & T function)
- Functional Block 2- Distress Detection logic --- Included in Architecture (D & T function)
- Functional Block 3- Triggering Criteria logic --- Included in Architecture (D & T function) and Airlines AOC function
- Functional Block 4- Distress tracking transmission --- Included in Architecture (AES function)
- Functional Block 5- Distress Report --- Included in Architecture (Airlines AOC)
- Functional Block 6- Flight crew Feedback --- Included in Architecture (ADT status announcement to Flight Deck)

Discussion, in terms of architecture framework components, of the architectures' functionality that supports the component.

STRAWMAN FOR ARINC PROJECT PAPER 680

Discussion of key assumptions and dependencies for the architecture.

Assumption 1: ADT function includes independent sensor input and independent power (including builtin battery).

Assumption 2: It is recommended the link A/C systems → ADT is unidirectional diode to prevent potential security breach from Ground systems and/or AISD domain. The only exception shown is ADT status going to flight deck (A/C systems domain). This exception will have to be reviewed as a team on how the potential security risk from AISD domain will be addressed.

Assumption 3: Ground based trigger can be used in the case of non-cooperative crew (malicious or incapacitated). This is coupled with the capability to cancel the trigger.

Assumption 4: No forced air cooling is required.

Assumption 5: These architectural block diagrams are applicable to new aircraft deliveries starting from Jan 2021 per the anticipated mandate.

Assumption 6: The objective is Architecture diagram does not require to be modified to meet the retrofit market needs.

Assumption 7: Security requirements for airborne segment and ground segment are TBD.

Discussion of key airplane infrastructure support and changes required to support architecture.

- Antenna Installation requirements
- Continuous power to ADT function and transceiver function
- Size requirements
- Harness routing requirements from ADT to Transceiver
- Other installation requirements TBD
- Tamper proof requirements

Discussion of key network support and changes required to support architecture.

Performance requirements for transceiver to transmit the distress signal
TBD

Message definition TBD

Discussion of key ground segment support and changes required to support architecture.

Performance requirements for Ground segment (Gateway and AOC) to process the distress signal and uplink ground based trigger TBD

STRAWMAN FOR ARINC PROJECT PAPER 680

Redundancy requirement for the ground infrastructure
Ground system may include a portion of trigger function.

3.5.3 Compliance with Requirements

Evaluate the architectures support for the minimum and optional requirements described in Appendix B (minimum requirement set spreadsheet) and for the GADSS CONOPS (Ver 6.0) State of the Operator Approval Criteria Recommendations (section 3.2.10) using the matrices in Appendix C.

Identify and provide textual/graphic descriptions and discussions of any major shortcomings and if and how they are expected to be addressed.

Provide textual/graphic descriptions and discussions of any additional capabilities or opportunities for improved distress capabilities and services not addressed in the requirements.

Identify and discuss requirements that potentially impose a significant cost or impact for the architecture and discuss where changes in requirements or alternative could potentially provide similar capabilities at a significantly reduced cost or impact.

Identify and discuss requirements where there is potential opportunity for the architecture to significantly exceed or improve on the required levels with minor impact and cost.

Predictive maintenance possibility.

Based on message data contents, additional requirements can be added.

Abnormal triggers that do not qualify as Distress trigger yet can be added.

Additional data to be downlinked (as requested by Ground segment)

Satcom voice (initiated from ground segment)

Manual trigger from the ground.

Datalink using ACARS

Bite request from Ground segment

Capability of exceeding 1 min requirement (customer request based)

Distress trigger generated from ADT Iridium may possibly be stored in alternate link such as DFDR or ELT-DT

3.5.4 Support for Related Services and Capabilities

Provide textual/graphic descriptions and discussions of any additional capabilities or opportunities for improved distress capabilities and services not addressed in the requirements. In particular address support for

5. Normal tracking
6. Abnormal and potential distress tracking

STRAWMAN FOR ARINC PROJECT PAPER 680

7. Implications for timely recovery of flight data
8. Post Flight Localization and Recovery

3.6 Dissimilar Complementary Architecture Study

3.6.1 Description of Architecture (HG/VR)

The concept of using multiple dissimilar complementary architectures (DCA) accounts for the fact that no single technology can possibly cover all incident scenarios, and allows suitable existing equipment aboard an aircraft to be included in the GADSS architecture. This implements the minimal change approach. Consequently, a dissimilar complementary architecture serves two purposes:

1. To implement the minimal change approach by specifically allowing the integration of existing equipment, or equipment designed to serve another purpose (e.g. surveillance).
2. To ensure that the overall objective of reliable and accurate location of an aircraft in distress can be met in a wider set of circumstances, for example by allowing two dissimilar technical solutions with complementary strengths and weaknesses to be regarded as a compliant means to satisfy the GADSS GAT requirement.

Therefore, it is the entire aircraft for which GADSS compliance is ascertained, rather than any one, single solution.

For example, ADS-B systems are designed to provide a surveillance function and are mandatory equipment in many regions. Real-time aircraft telemetry satellite communication systems are designed to provide real-time access to FOQA data and provide operational and maintenance benefits. Both contain independent location information. Both systems in combination allow an aircraft to be tracked even when the ADS-B function is compromised, so long as the satellite communication link for aircraft data remains operational and vice versa. In combination, both systems can offer a higher combined aircraft tracking reliability. In the MH370 scenario, where the ADS-B transponder stopped broadcasting but the satellite terminal remained operational, this solution would have likely provided a precise location of the aircraft even prior to the end of flight.

The following candidate architectures were identified as possible constituents of a DCA solution (refer to for an overview of the most likely combinations):

Air to Ground link (Dissimilar):

1. Dual SATCOM (Inmarsat + Iridium)
 - a. In this scenario, the aircraft is equipped with two satcom terminals, one for Inmarsat and another for Iridium. It depends on the user's preference to determine which network to use as prime and which to use as a backup service. A separate routing logic may also be available to route data according to network availability.

STRAWMAN FOR ARINC PROJECT PAPER 680

- b. In case where the terminal manufacturer included both Inmarsat and Iridium radios in the same physical unit, this arrangement provides backup for cases involving antenna failure (including failure of the structure supporting the antenna), satellite communication network failure and aircraft attitude and location related network availability failures.
- c. In case where two individual terminals are installed, the system provides an additional dissimilar redundancy in case of satcom terminal failure.

2. SATCOM + ELT

- a. In this scenario, the aircraft is equipped with an: (a) ADT-Iridium or ADT-Inmarsat and b) and one legacy ELT system.
- b. In this scenario the satcom system is able to house the triggering functionality or it is able to receive triggering information from an independent ADT system/source. Once an ADT system triggers, this allows the satcom to transmit data to the AOC via its network.
- c. At the same time the Satcom or ADT system can be connected to the existing ELT system onboard (with the correct connection capabilities) to be triggered in flight and prior to impact to inform the Rescue Coordination Centre (RCC) of an ED-237 event. The advantage is that both the operator and the RCC would be informed simultaneously. Another advantage is that existing ELT systems and potentially existing Satcom systems can be utilized for this purpose.

3. SATCOM + ELT-DT

- a. This architecture involves implementation of two independent autonomous distress tracking functionalities: (a) ADT-Iridium or ADT-Inmarsat and (b) ELT-DT. Or the ADT system can also be an independent system used for triggering functionalities.
- b. It will have to be decided which one of these dissimilar architectures is primary and which one is secondary. The other distinct possibility is both dissimilar architectures are simultaneously operational. So, if there is a true abnormal distress condition on aircraft, the distress trigger is transmitted simultaneously down to airlines AOC and the RCC by each system.
- c. If there are dissimilar triggering criteria in each system it is anticipated, there will be some teething problems during which one architecture reaches a conclusion that there is distress condition and transmits a trigger and the other architecture reaches a conclusion that there is no distress trigger or the link has failed. In such situations, AOC operational software should reach a correct decision as far as the genuineness and correctness of the trigger.

Commented [VR18]: Description added as indicated under SATCOM + ELT-DT section.

STRAWMAN FOR ARINC PROJECT PAPER 680

- d. It needs to be evaluated if the distress trigger generated by one architecture should also be stored in airborne repository of the other architecture, for example, SATCOM -ADT generated distress trigger is also stored in EL-DT distress repository and vice versa. This will be helpful, if the Satcom link completely fails inflight and there is a way to make this trigger available for recovery in a crash survivable hybrid ELT-DT.
4. SATCOM + ADS-B Out
- a. This architecture refers to cases where satcom ADT and ADS-B-out capabilities are installed and the respective services are available. ADS-B was originally designed to provide a radar-like surveillance function, and in doing so, also satisfies GADSS GAT requirements at higher-than-necessary update rates.
 - b. In scenarios where both systems read data from the same location data source, no redundancy is provided for navigation system failures.
 - c. In scenarios where the satcom system is used to stream aircraft telemetry in real time, and where that telemetry includes location data gathered from various sources such as INS, external GNSS and built-in GNSS receivers, location data source redundancy may also be claimed.

STRAWMAN FOR ARINC PROJECT PAPER 680

5. ELT + ADS-B Out

- a. This architecture refers to aircraft with ADS-B-out capabilities and at least one ELT installed, in airspace where the respective services are available. ADS-B was originally designed to provide a radar-like surveillance function, and in doing so, also satisfies GADSS GAT requirements at higher-than-necessary update rates.
- b. In this scenario, where the ADS-B function can and is being used for GAT, the ELT serves as a backup for determining the point of end of flight.
- c. Because the ELT is a self-contained unit, this scenario provides dissimilar backup for power and navigation system failures.

6. ELT-DT + ADS-B Out

- a. In this scenario, the aircraft is equipped with both an: (a) ELT-DT and b) an ADS-B out system.
- b. In this scenario the ELT-DT system or the ADS-B out system needs to be able to house the primary triggering functionality (for this example, the ELT-DT system does the primary triggering as it already has existing infrastructure to house the triggering functionality). Once the ELT-DT system triggers it transmits relevant information to the RCC via its network.
- c. At the same time the ELT-DT system can be connected to the existing ADS-B out system onboard (with the correct connection capabilities) to be triggered in flight and prior to impact to inform the Air Traffic Service (ATS) of an ED-237 event (a new ADS-B label would be required for this functionality). The advantage is that both the RCC and the ATS would be informed simultaneously. Another advantage is that existing ADS-B out systems could potentially be utilized for this purpose. A further advantage is that the ADS-B out information could potentially also be relayed to the operator/AOC thereby informing all three intended GADSS information recipients (AOC, ATS, RCC).

7. SATCOM + ELT + ADS-B Out

- a. In this scenario, the aircraft is equipped with an: a) ADT-Iridium or ADT-Inmarsat and b) a legacy ELT and c) an ADS-B out system.
- b. In this scenario the Satcom system needs to be able to house the primary triggering functionality or it is able to receive triggering information from an independent ADT system/source. Once the SATCOM/ADT system triggers it transmits relevant information to the AOC via its network.
- c. At the same time the SATCOM/ADT system can be connected to the existing ELT and the existing ADS-B out system onboard (with the correct connection capabilities) so as to be triggered in flight and prior to impact to inform simultaneously the RCC and the ATS

STRAWMAN FOR ARINC PROJECT PAPER 680

of an ED-237 event (a new ADS-B label would be required for this functionality). The advantage is that all three intended GADSS information recipients (AOC, ATS, RCC) would be informed simultaneously.

8. ELT + ELT-DT Hybrid

- a. The ELT + ELT-DT Hybrid architecture brings together an integrated solution that meets legacy ELT requirements as well as new ELT-DT functions to meet ADT requirements. The solution could be comprised of a single LRU which is crash survivable and has a crash detected switch to activate, which meets the existing ELT functional requirements. The distress determination and triggering logic would likely come from a separate source and thus the trigger would be a new input to the ELT + ELT-DT Hybrid system. Existing flight deck interfaces for Self Test and Arm would remain the same, with an additional flight deck switch for manual distress activation.
- b. The ELT + ELT-DT Hybrid architecture would retain existing power interfaces; 28 VDC aircraft power in addition to a self contained backup battery that meets the COSPAS-SARSAT operating lifetime performance requirements.

Airborne Routing logic functions (Dissimilar):

CMU
ATSU
ADT router function (dedicated)

Flight crew interface (Dissimilar):

MCDU interface
Flight Crew Panel
Distress status indication (dedicated)
ELT status indication

Aircraft Status Information and Distress Trigger Function

ADT on-board computer (dedicated)
AOC data integration and distress declaration
ADT automatic output
AOC requested data from ADT
Flight crew communications – radios, datalink, etc

STRAWMAN FOR ARINC PROJECT PAPER 680

- ATC data, including radar, flight planning, etc
- COSPAS/SARSAT data
- ADS-B data
- etc
- COSPAS/SARSAT data integration and distress declaration
- ELT data
- ELT-DT data (if installed)
- Other input data

System Power (dissimilar)

Minimum system function sets can be allocated to dissimilar power sources (such as local batteries, or aircraft emergency battery bus) to ensure some level of functionality in the event of a loss or normal power.

Commented [HG19]: Insertion by Lars Rosenblad

In order for the solution to comply with the GAT standard, the overall system must be shown to maintain the GAT function even if one constituent system ceases to operate. Consequently, systems must not be mutually dependent on one another to satisfy the DCA standard

Commented [HG20]: Lars: ". I don't think there is an additional redundancy requirement as a result of combining dissimilar systems. However, there are the GAT redundancy requirements for various functions, such as position, loss of power, etc that must be addressed in a combined systems. For instance, if every element in the combined system uses the existing aircraft navigation position as its position source, the system would not be compliant. But if the DCA system provides an independent position source that is used by multiple elements of the system (for instance, Iridium and Inmarsat downlinks), that would be acceptable."

Table 4: Overview of the most common dissimilar complimentary architectures.

Capability	Distress Reporting	Power Resilience	Navigation Resilience	Global Coverage	Aircraft Dynamics	Tamper-Proof	Crash Survivability
ELT	M	H	L	H	M	H	H
ELT-DT	H	H	H	H	M	H	L
Inmarsat SATCOM Safety Services (Voice/data)	H	L	L	M	M	L	L
Iridium SATCOM Safety Services (Voice/data)	H	L	L	H	M	L	L
ADS-B Out XPDR	M	L	L	H	VH	L	L
Iridium SATCOM Tracker	H	H	H	H	M	H	L

STRAWMAN FOR ARINC PROJECT PAPER 680

3.6.2 Architecture Mapped to the Architecture Frame Work (BT)

To ascertain that the resulting architecture is correctly mapped to the overall Architecture Frame Work, the aircraft system including complementary dissimilar redundant components must be taken into account. Table 1 shows the most prominent and likely configurations mapped to the overall framework.

Commented [VR21]: Reference added.

3.6.3 Compliance with Requirements (CA)

Compliance with requirements in a dissimilar complementary redundancy must be ascertained at overall system level. This means, it is the aircraft itself for which compliance with requirements must be shown. Compliance for individual system components can be gleaned from the relevant chapters in this document. Table 1 lists examples for common, or likely, expected combinations but shall not be understood as limitative.

Commented [VR22]: Reference added.

3.6.4 Support for Related Services and Capabilities (VR / MB IOU)

Provide textual/graphic descriptions and discussions of any additional capabilities or opportunities for improved distress capabilities and services not addressed in the requirements. In particular address support for

1. Normal tracking
2. Abnormal and potential distress tracking
3. Implications for timely recovery of flight data
4. Post Flight Localization and Recovery

Also:

Predictive maintenance

FOQA data

Real-time crisis management and intervention

3.7 Detection/Triggering Architecture Study

Internal note: since this section is focused on the generic detection/triggering architecture, rather than the architecture of a certain system, the proposed ARINC AEEC SAI Global Aircraft Tracking Architecture template has not been used. Instead, this document focus on developing the requirements presented in the Concept of Operations for the Global Aeronautical Distress & Safety System (GADSS), v. 6.0, and EUROCAE ED-237: Minimum Aviation System Performance Specification for Criteria to Detect In-Flight Aircraft Distress Events to Trigger Transmission of Flight Information.

STRAWMAN FOR ARINC PROJECT PAPER 680

3.7.1 Description of Architecture

The Detection/Triggering Architecture herein proposed is not technology specific dependent. Rather, this is the deployment into lower level requirements of the architecture structure of the GADSS functional architecture (as agreed among the various SAI Global Aircraft Tracking participants in the Aug 2017 meeting, in Seattle) and the textual descriptions of Concept of Operations for the Global Aeronautical Distress & Safety System (GADSS), v. 6.0, and EUROCAE ED-237: Minimum Aviation System Performance Specification for Criteria to Detect In-Flight Aircraft Distress Events to Trigger Transmission of Flight Information.

The next figures present the proposed Detection/Triggering Architecture.

STRAWMAN FOR ARINC PROJECT PAPER 680

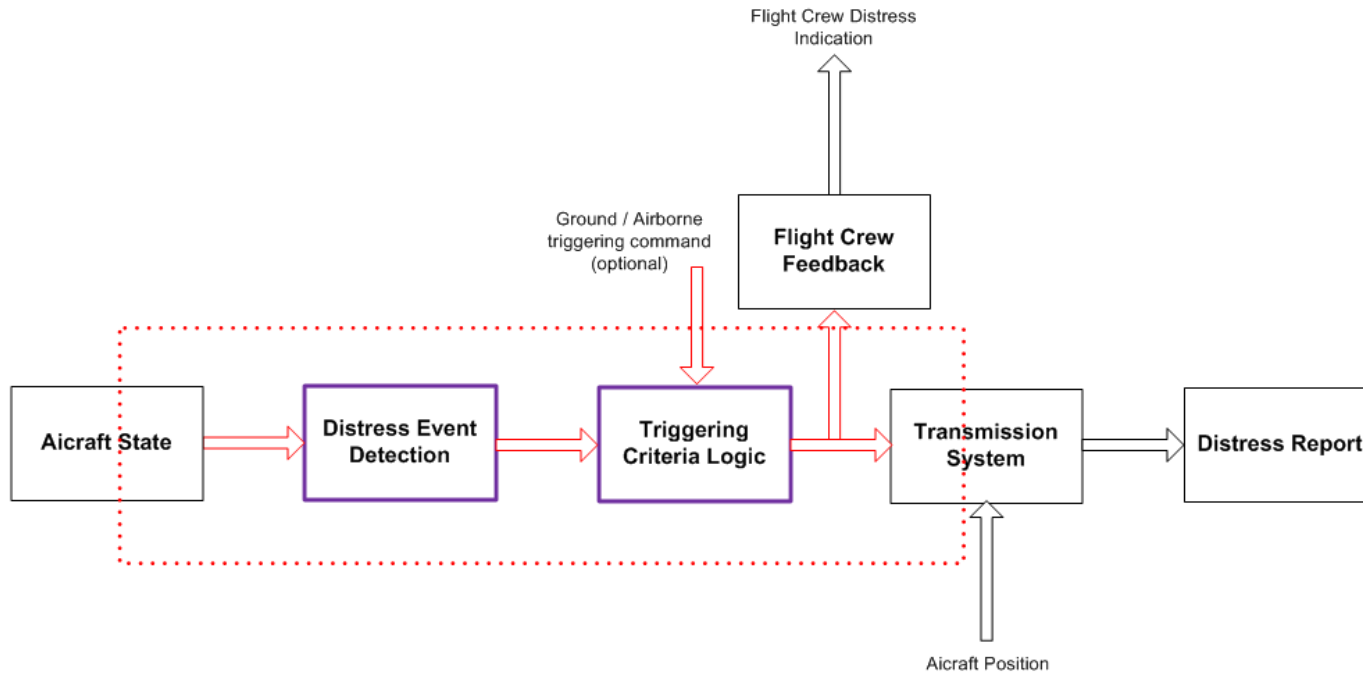

Figure 35: ADT functional architecture.

STRAWMAN FOR ARINC PROJECT PAPER 680

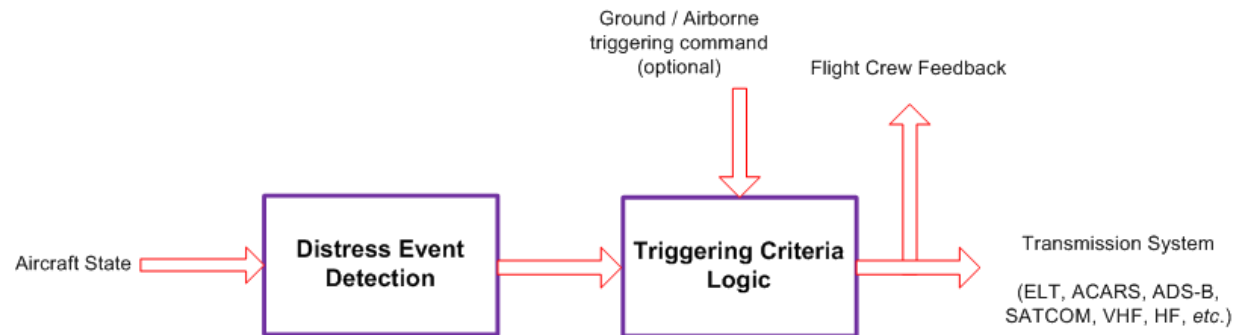

Figure 36: The scope of work of this document: the Distress/Triggering architecture and its interfaces.

STRAWMAN FOR ARINC PROJECT PAPER 680

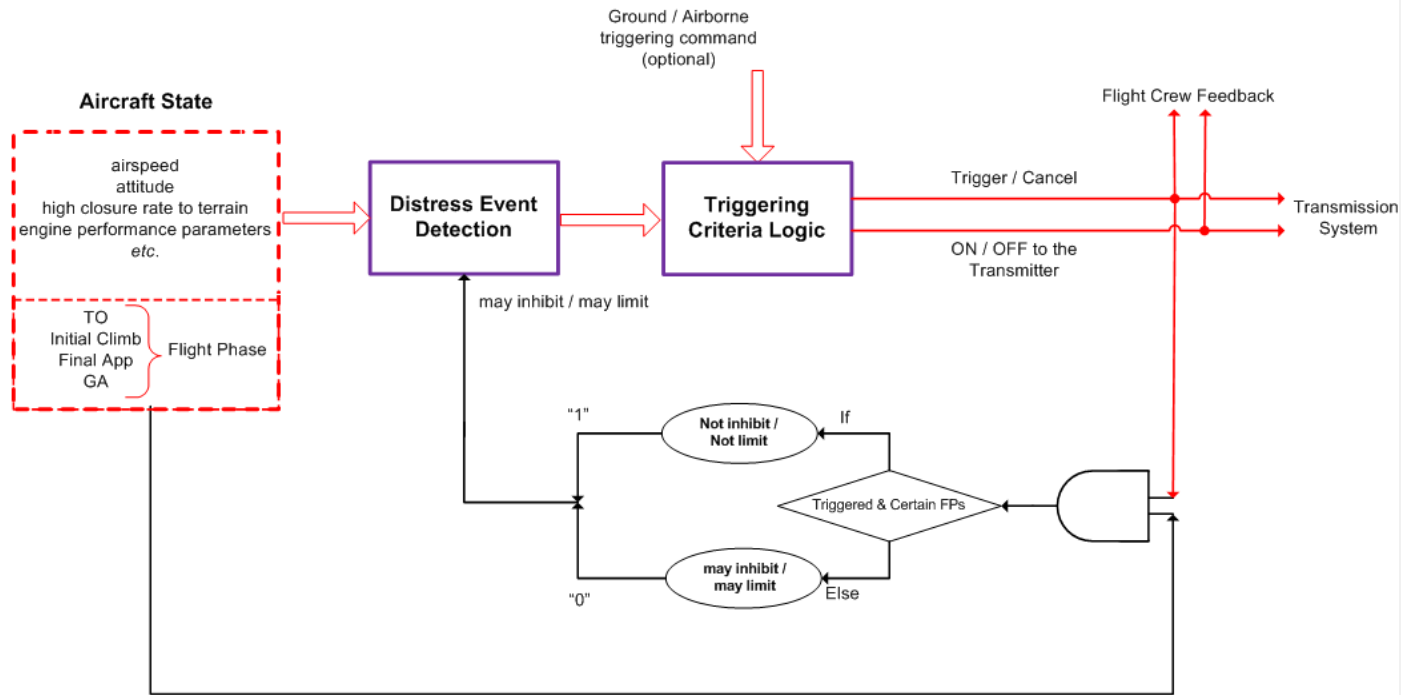

Figure 37: Further detailing of the Distress/Triggering architecture and its interfaces; and the minimization of nuisance triggers by inhibition of the logic in certain flight phases.

STRAWMAN FOR ARINC PROJECT PAPER 680

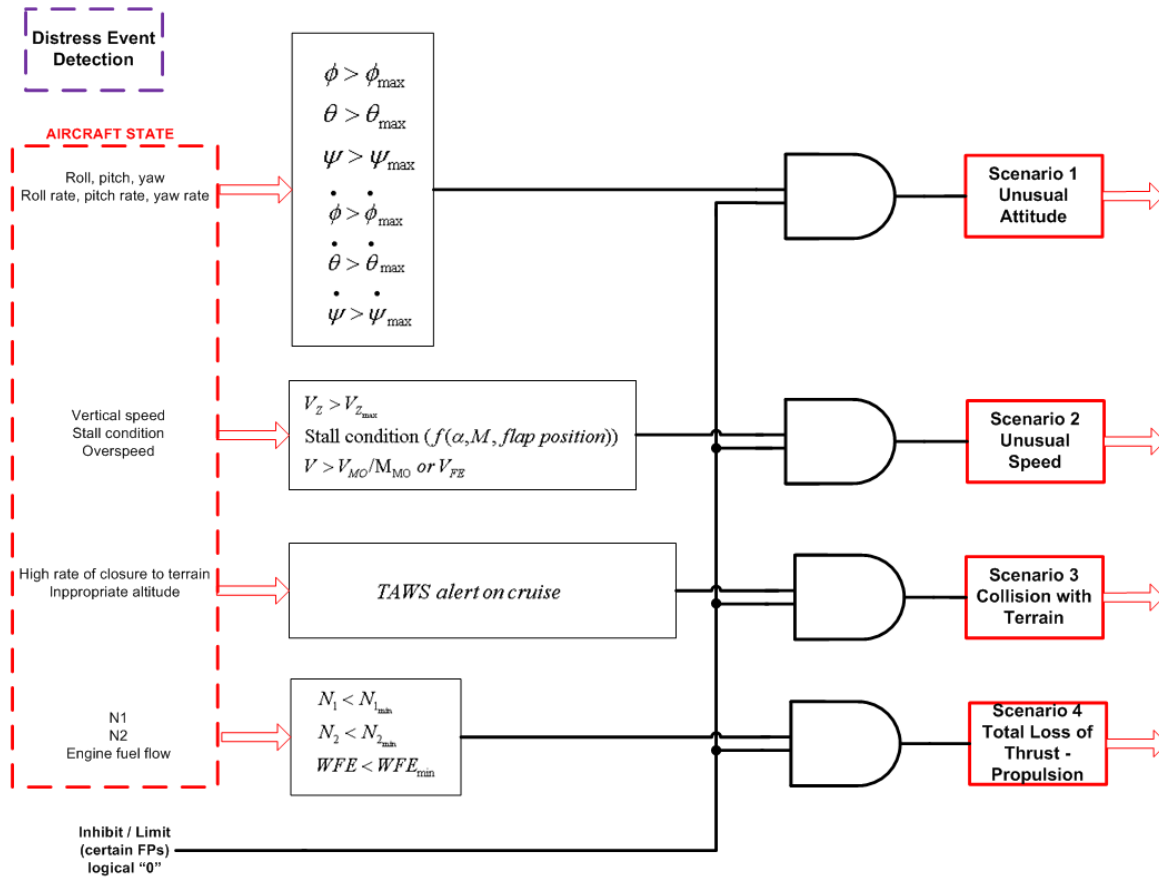

Figure 38: Distress Event Detection architecture.

STRAWMAN FOR ARINC PROJECT PAPER 680

Triggering
Criteria Logic

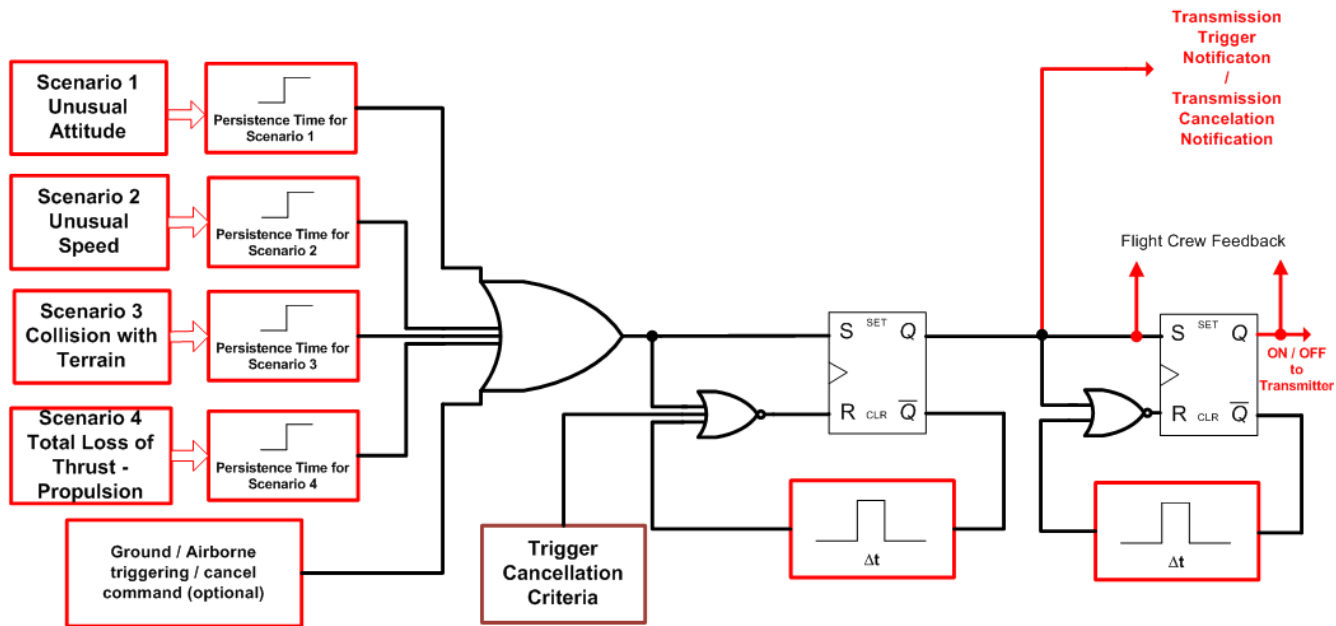

Figure 39: Triggering Criteria Logic architecture.

STRAWMAN FOR ARINC PROJECT PAPER 680

Figure 1 presents the ADT functional architecture, as agreed among the various SAI Global Aircraft Tracking participants in the Aug 2017 meeting, in Seattle. Note that the red dotted rectangle indicates the two blocks that this document will focus on: the distress event detection and the triggering criteria logic and their adjacent interfaces.

Figure 2 reaffirms the scope of this document - the detailing of the distress event detection and the triggering criteria logic blocks and their adjacent interfaces.

Figure 3 further expands the blocks and interfaces of Figure 2.

First, there is a broad indication of the parameters that compose the block "Aircraft State". A first set of parameters (airspeed, altitude, engine performance parameters, *etc.* - all indicated in the text of ED-237) is indicated as inputs to the Distress Event Detection block (these parameters will be more detailed in the Figure 4 explanation paragraph).

A second set of parameters (certain flight phases - take-off, initial climb, final approach, go-around) may also be used to inhibit/limit the Distress Event Detection block, in order to minimize the nuisance trigger rate. Note that this inhibition (which is not mandatory to implement, but it is optional) could be directed to the Triggering Criteria Logic block or even the Transmission System block (which lies outside the scope of work of this document), instead of the Distress Event Detection block. All these structures are possible architecture implementations. For the sake of drawing representation, it was chosen for the inhibit/limit signal to be sent to the Distress Event Detection block, but this does not preclude other architecture structures. Finally, in terms of nomenclature, "inhibit/limit" may also be understood as "disarmed".

Figure 3 also indicates the outputs to the Transmission System and Flight Crew Feedback blocks. The "Transmission Trigger Notification / Transmission Cancel Notification" (or, in short, "Trigger / Cancel") and the "ON / OFF" signals are both sent to the Transmission System and Flight Crew Feedback blocks.

Figure 4 details the Distress Event Detection block from the previous figures.

It further indicates what parameters should be provided to the Distress Event Detection block. These parameters are but suggestions based on the proposed scenarios in ED-237. Also, although it is not detailed in the figure, it is recommended that different data sources are used (for example, aircraft altitude from Air Data Computer # 1 and Air Data Computer # 2), in order to increase the system's robustness and also reduce the trigger nuisance rate. Dissimilar sources may also be used, if they comply with the proper accuracy, availability, continuity and integrity requirements¹. However, note

¹ Accuracy, availability, continuity and integrity may be defined as follow:

STRAWMAN FOR ARINC PROJECT PAPER 680

that the use of redundancy and dissimilar sources may not be necessary, depending on the integrity of the inputs and the technology chosen to implement the ADT system.

Although there is no firm requirement for continuity/availability, there is a recommendation that the ADT system should comply with a continuity of 0.999.

Figure 4 also indicates some logics that could be implemented in order to address the four scenarios listed in ED-237. Note that these inputs and logics presented herein are but suggestions to comply with the objectives of ED-237. Other set of parameters and logics, including integration of these parameters with the aircraft flight dynamics, could be implemented to comply with the very same objectives. Note that these logics may also vary according to the aircraft type, model, flight phase, *etc.* Also, note that these logics could be inhibited/limited by certain flight phases (as previous indicated in Figure 3 and as indicated in Figure 4 with the four logical "ANDs").

In regards to scenario 1 - Unusual Attitude -, it was established that if roll, pitch, yaw and its associated rates were greater than certain values, then a distress condition would be detected. These values may vary according to the aircraft flight dynamics and they could be jointly assessed.

In regards to scenario 2 - Unusual Speed -, much like scenario 1, it was established that if vertical speed and the aircraft airspeed were greater than certain values, then a distress condition would be detected. For low speed conditions, a distress condition would be detected if the aircraft entered into a stall condition (which is a function of angle of attack, Mach number and flap position). Again, all these values and relations may vary depending the aircraft flight dynamics.

In regards to scenario no. 3 - Collision with Terrain -, it is necessary to point out that this condition may prove to be somewhat problematic to implement. Not because of the feasibility of the technical solution associated with it, but because of the purpose of the ADT system itself. As it is known, ADT is the capability that enables the aeronautical safety system to identify and track an aircraft in distress. However, in the large majority of accidents involving CFIT (Controlled Flight Into Terrain), the pilots were in contact with air traffic control (ATC) at the time of the accident and receiving radar service. Therefore, aircraft tracking does not appear to be an issue associated with

- Accuracy: it is a degree of conformance between the estimated or measured value and the true value. For aircraft positioning, it is the difference between the estimated and the true position of the aircraft.

- Availability: it is the attribute that a system or item is performing to specification. It is sometimes expressed in terms of the probability of the system (item) not providing its output(s) (*i.e.* unavailability).

- Continuity: it is the probability that a system or item will perform a required function under specified conditions, without failure, for a specified period of time. Sometimes this is called reliability.

- Integrity: it is the attribute of a system or an item indicating that it can be relied upon to work correctly. It is sometimes expressed in terms of the probability of not meeting the work correctly criteria.

For the ADT system, it is required an accuracy of 0.1 NM (in regards to aircraft positioning) for 95% of the time and it is recommended an availability of 0.989, a continuity of 0.999, and an integrity of $1 \cdot 10^{-5}$.

STRAWMAN FOR ARINC PROJECT PAPER 680

CFIT. The real issue with CFIT is that both pilots and controllers involved in such kind of an accident all appear to have been unaware that the aircraft were in danger. It is recognized that increased altitude awareness and better preflight planning would likely have prevented the majority of these accidents. And, in regards to situational awareness, there already exists a Terrain Awareness and Warning System (TAWS) onboard the aircraft. Thus, it appears that the ADT system is not expected to replace the TAWS. In light of these comments, it is necessary to question: is it really necessary for scenario 3 to exist? This concern seems to be also shared by ICAO. In scenario 2-6 of the table of page 45 of the Appendix C of the GADSS CONOPS document, v. 6.0, ICAO has indicated with a "TBD" if in such a scenario the ADT system should be automatically activated. The only scenario that the ADT system may appear to have certain relevance is the one in which there is the possibility of a CFIT in the middle of the cruise in a remote surveillance area.

In regards to scenario 4 - Total Loss of Thrust / Propulsion -, it was established that if the speed of the low and high pressure rotor and the engine fuel flow below a certain value for all the engines, than a distress condition would be detected. ED-237 was specifically cryptic in regards to this scenario stating that "engine performance parameters" should be monitored. Therefore, other parameters may also be monitored, and they also may depend on the aircraft flight dynamics.

Despite the fact that these logics may vary according to the aircraft type/model/flight dynamics/etc., they do present a minimum set of conditions to be monitored, nonetheless.

Other conditions, not included in these four scenarios, could be also be monitored. And they could be used to identify abnormal conditions and potential distress situations. But these are outside the scope of this document (although they are briefly commented in item 2.1.2).

Note that there may be loss of parameters that are inputs to the various scenarios that constitute the Distress Event Detection architecture. In that case, the ADT system may function in a "degraded" mode, since one scenario may be affected this loss, while others may not.

Finally, the outputs of this block to the Triggering Criteria Logic block are further detailed. Note that each scenario output block could be one bit or a set of bits to summarize the associated particular condition (e.g.: scenario 1 could present 6 bits to identify each attitude/attitude rate condition, or just one that summarizes the overall unusual attitude condition).

Figure 5 details the Triggering Criteria Logic.

The outputs of the Distress Event Detection Logic block are the inputs of the Triggering Criteria Logic block.

Note that a Ground / Airborne triggering / cancel command may also be an input to this block. Note that the ground triggering/cancel command would account for the ADT system being triggered or being cancelled by the ground segment. On the other hand, the airborne triggering/cancel command accounts for the ADT system being triggered or cancelled by the

STRAWMAN FOR ARINC PROJECT PAPER 680

flight crew. These inputs are not mandatory, but it an option, depending on the technology and the system architecture chosen by the applicant.

Since the four ED-237 scenarios are very different in nature, each scenario input has its own persistence time (which may vary according to the aircraft flight, flight phase, flight dynamics, *etc.*). A logical "OR" accounts for the occurrence of just one or more scenarios at the same time. Two logical Set/Reset flip-flops are used to derive the "Trigger / Cancel" and "ON / OFF" signals. The flip-flop on the left accounts for the "Trigger / Cancel" notification; while the flip-flop on the right accounts for the "ON / OFF" signal. Another persistence time (indicated in the figure by a block with the symbol " Δt ") is added to the logic of both flip-flops to ensure that the "Cancel" and "OFF" signals last enough time to ensure that the flight crew have regained control of the aircraft and are maintaining a stable flight regime or the aircraft has landed safely and that the "Cancel Notification" will be generated for a duration sufficient for the transmitter to receive it. Finally, the "Trigger Cancellation Criteria" block has been added to the "Cancel Notification" logic to address paragraph 3.2.3 of ED-237.

The "Trigger / Cancel" notification and "ON / OFF" signal, which are inputs to the "Flight Crew Feedback" block, can also be derived from the Transmitter (which will act as a signal router), instead of "Triggering Criteria Logic" block.

For systems in which the transmitter sends signal directly to the Search and Rescue Satellite-Aided Tracking System, the airborne triggering / cancel command and ON / OFF signal will be one and the same and it may be directed connected to the transmitter.

Finally, it is worth noting that this architecture could support abnormal and potential distress tracking; and recovery of flight data.

Abnormal and potential distress events could be inserted as new logic blocks in figure 4, adding new scenarios (Scenario 5, Scenario 6, *etc.*).

Figure 5 would have to be modified correspondingly to address these new scenarios. Depending on the technology chosen to implement the ADT system, the new scenarios inputs could be added to the logic "OR" in figure 5, or they could be input to a parallel "OR", generating distinct signals for notification (*e.g.*: if one implements the ADT system through ELT-DT technology, one would not desire for the beacon to be activated in an abnormal or potential distress situation).

As for recovery of flight data, once a distress situation is detected and a notification is triggered, this could also be the input for the transmitter to broadcast flight recorder data, as well as the aircraft's position.

3.8 Airplane Integration Architecture

3.8.1 Requirements & Recommendations

Internal note: since this section is focused on certain aspects of aircraft integration, rather than the architecture of a certain system, the proposed ARINC AEEC SAI Global Aircraft Tracking Architecture template has not been used. Instead, this document focus on requirements and

STRAWMAN FOR ARINC PROJECT PAPER 680

recommendations for the design of the ADT system, considering certain aspects of aircraft integration.

STRAWMAN FOR ARINC PROJECT PAPER 680

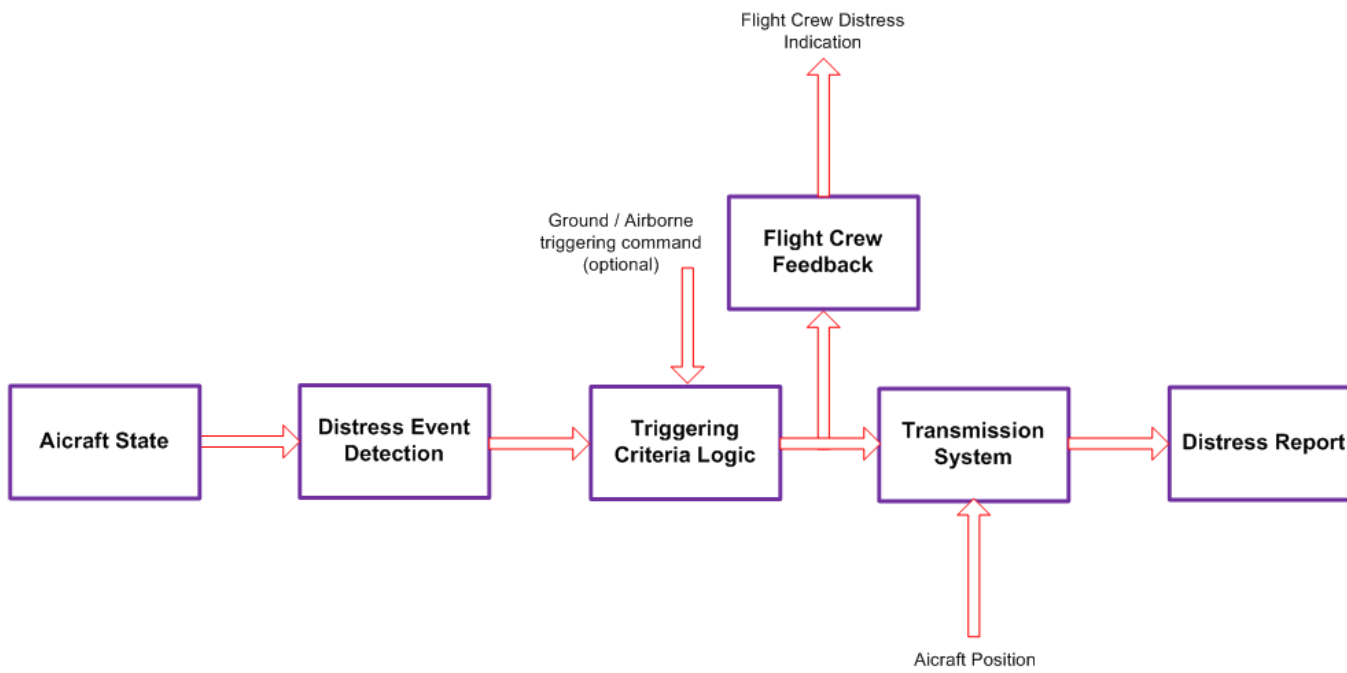

Figure 40: ADT system functional architecture.

STRAWMAN FOR ARINC PROJECT PAPER 680

The functional architecture presented in Figure 1 may be physically implemented in a plethora of different structures and technologies.

In regards to architectural structures, there may be functional allocation to different components. For example, the "Distress Event Detection" and the "Triggering Criteria Logic" functional blocks could be implemented in a single LRU (line replaceable unit), while the "Transmission System" block could be implemented by a Satellite Communication Radio; or all the three functional blocks could be implemented in just one LRU. In another example, the "Distress Event Detection" and the "Triggering Criteria Logic" functional blocks could be implemented in a ground system, while the "Transmission System" block is necessarily implemented in an airborne system.

In regards to technologies, part of the ADT functional blocks could be implemented by ELT-DT, Satcom (Iridium, Inmarsat), Spaced Based ADS-B, etc. or in a combination of different technologies. Each technology has its own merits and disadvantages that have to be assessed jointly to determine the best tradeoff for the system implementation.

It is out of the scope of this document to indicate which technology or structure is better or worse to implement the ADT functionality. It is up to the system designer and/or aircraft OEM applicant to determine, based on the aircraft type and its characteristics, the best possible solution. For instance, it does not make sense to indicate that the "Distress Event Detection" and the "Triggering Criteria Logic" blocks should be implemented in a LRM (line replaceable module) if the aircraft systems were not implemented in a IMA (Integrated Modular Avionics) architecture.

However, some recommendations and a few requirements may be issued, regardless of technology, structure and architecture.

3.8.1.1 ADT system equipment

Recommendation # 1: the ADT system should use as much as possible already installed equipment in the aircraft (data collectors, radio transmitters, antennas, etc.) for its implementation.

Comment: This recommendation is more in light of retrofit and standardization along an OEM's fleet. For new build aircraft, new systems may be designed, although they have the downside of possible not having a uniform solution along an existing OEM's fleet, when one considers retrofit. For already existing aircraft, this recommendation aims to make the aircraft retrofit less strenuous for both the operator and the OEM. For example, if the aircraft has an already installed Satcom system (and if the Satcom technology is the one chosen by the operator/OEM to implement the ADT

STRAWMAN FOR ARINC PROJECT PAPER 680

system), it makes more sense to use that system in the ADT implementation, instead of adding a new transceiver just for the ADT system. It is preferable to add as few components/modifications as possible. Some figures are presented below of possible integration schemes using already installed equipment. Note that these figures are generic architecture representations, not binding to the system designer, and not presenting all connections and/or details associated with the system (for instance, battery power - that might be used in light of the ADT system's resilience requirement - is not depicted in these figures; or - for the airborne architectures – the optional ground triggering command).

DRAFT

STRAWMAN FOR ARINC PROJECT PAPER 680

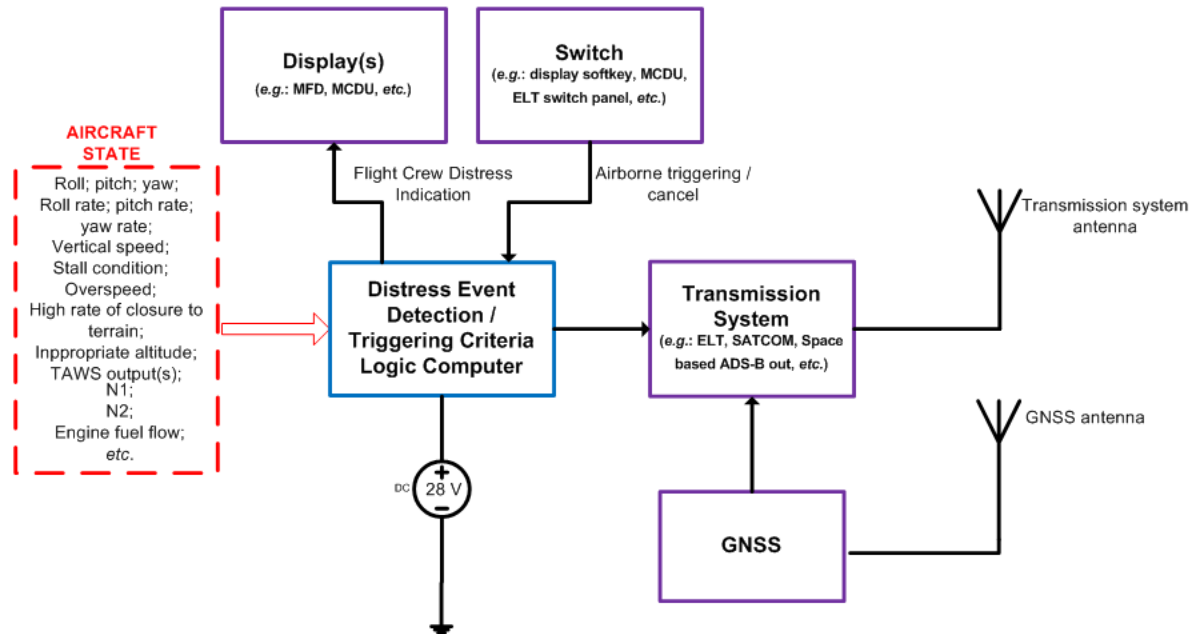

Figure 41: Possible ADT system architecture. A new computer unit/computer module is inserted to compute the distress event / triggering criteria logic.

Note that in this figure not all connections are represented (for instance, the optional ground triggering command could be represented by an arrow coming from the transmission system to the distress / triggering computer).

STRAWMAN FOR ARINC PROJECT PAPER 680

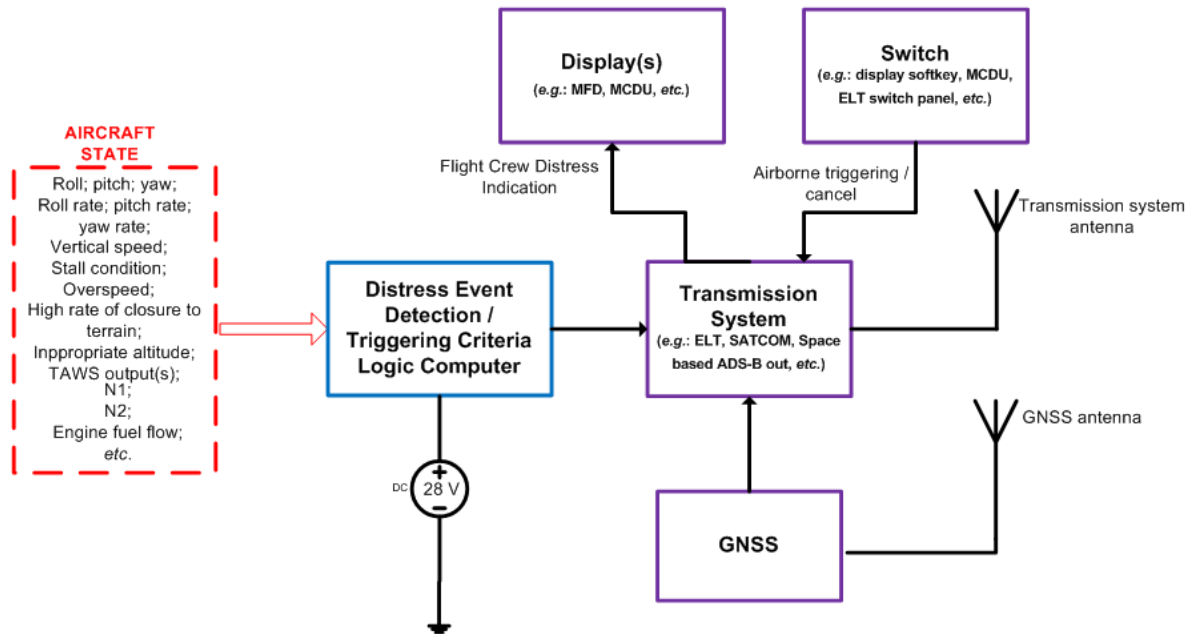

Figure 42: Possible ADT system architecture. Note that this figure differs from Figure 2, in the aspect that the switch and the display blocks are directly connected to the transmission system.

STRAWMAN FOR ARINC PROJECT PAPER 680

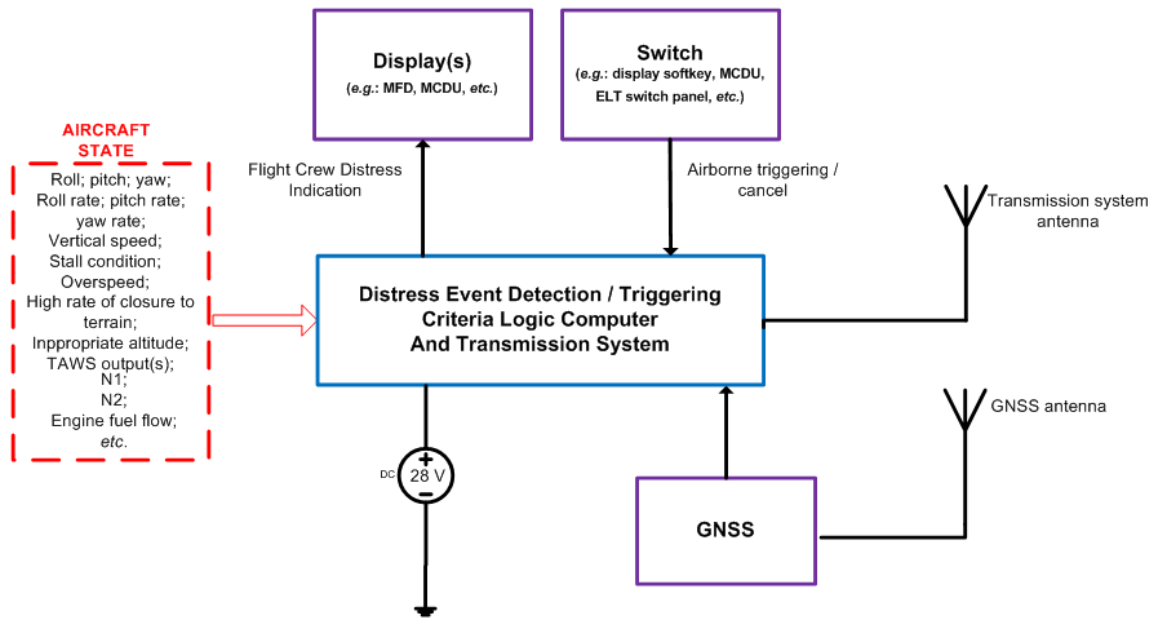

Figure 43: Possible ADT system architecture.

Note that in this figure, there is only one unit that computes the distress event detection / triggering criteria logic and that also transmits the distress notification. This architecture, depending on the aircraft, may present some challenges, since it may require the replacement of the transmitter system.

STRAWMAN FOR ARINC PROJECT PAPER 680

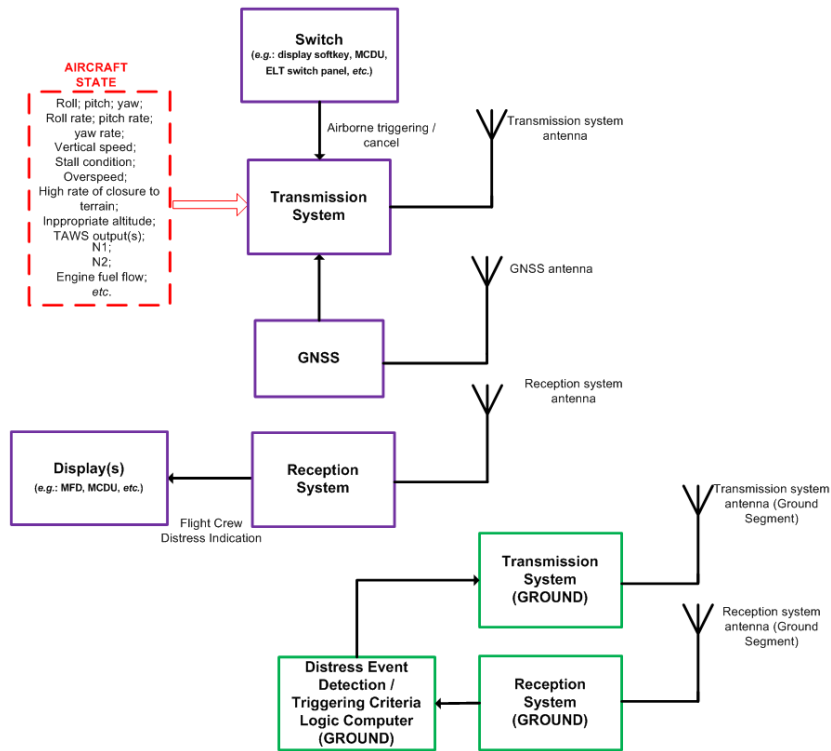

Figure 44: Possible ADT system architecture. In this scheme, the distress event detection / triggering criteria logic computing is performed on the ground.

STRAWMAN FOR ARINC PROJECT PAPER 680

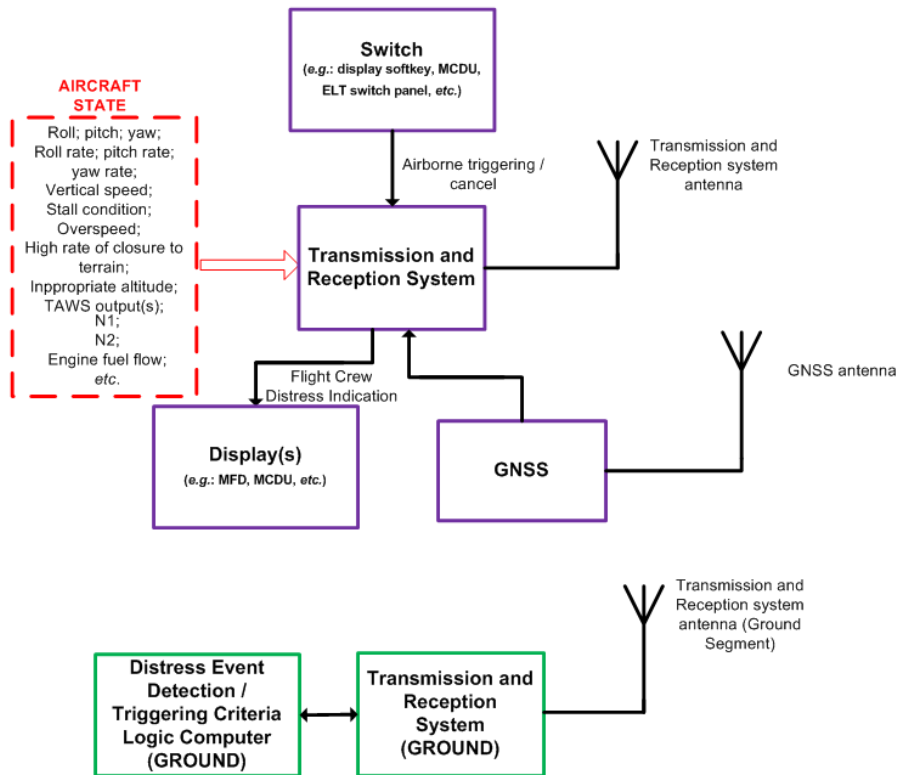

Figure 45: Possible ADT system architecture. Note that this figure only differs from Figure 5, in the aspect that both the airborne and ground transmission and reception systems are integrated.

STRAWMAN FOR ARINC PROJECT PAPER 680

3.8.1.2 Electrical interfaces and data bus

Recommendation # 2: the data inputs and outputs to/from the ADT system, as well as the system's internal data interfaces, should be commonly used standard buses (e.g.: ARINC 429, ARINC 717, etc.).

Comment: This recommendation aims to facilitate the ADT system integration with the aircraft. ARINC 429 and 717 are pretty common standard avionics buses and are very likely to exist in the large majority of aircraft.

Recommendation # 3: inputs to the Distress Event Detection Block should be among the 14 CFR Part 121/125 FDR listed parameters (Appendix M and E, respectively); or, if not part of such a list, the parameters should be already available in the aircraft's data buses.

Comment: This recommendation also intends to facilitate the ADT system integration with the aircraft and is also related to recommendation # 2. ARINC 717 is an almost ubiquitous bus in 14 CFR Part 25 aircraft; and it would facilitate aircraft integration if the already available parameters in that bus were used instead of ones that could not be readily accessible and would require an interface modification, in order to make them available.

Recommendation # 4: it is recommended to use different sources for the inputs to the Distress Event Detection Block in order to assure system architecture redundancy and to reduce the nuisance trigger rate.

Comment: This recommendation comes in light of good design practices: redundancy and the use of dissimilar sources. By using more than one data source, it is less likely that the loss of one input will affect the ADT system. By using dissimilar data sources, it is less likely that the ADT system is triggered erroneously (the data of both sources should match to a certain extent, otherwise a false trigger notification could be issued). However, note that the use of redundancy and dissimilar sources may not be necessary, depending on the integrity of the inputs and the technology chosen to implement the ADT system.

3.8.1.3 Electrical power

Recommendation # 5: the ADT system should accept 28 V DC power input.

Comment: This recommendation intends to facilitate the ADT system integration in the world's aircraft fleet. 28 V DC is an ubiquitous electrical bus for avionics systems in the large majority of the aircraft.

Recommendation # 6: if the system designer or the aircraft OEM decides to make use of a battery, in order to make the ADT system resilient to power failures, then its charge must be enough to assure that, in the event of an aircraft electrical power loss, the ADT system will continue its transmission for the expected duration of the remaining flight.

Comment: It is important to have in mind that the ADT system must be resilient to power failures "as practical as possible", as indicated in the GADSS CONOPS document, v. 6.0.

STRAWMAN FOR ARINC PROJECT PAPER 680

3.8.1.4 Installation aspects: Environmental Qualification

Recommendation # 7: the equipment of the ADT system should be RTCA DO-160G (or equivalent standard) qualified according to each equipment installation zone of the aircraft.

Comment: Environmental qualification is necessary to assure that the system's equipment are installed in the appropriate aircraft zones. The equipment qualification also facilitates the OEM's Zonal Safety Analysis (ZSA) and Particular Risks Analysis (PRA).

3.8.1.5 Zone installation aspects

Requirement # 1: the failure of the ADT system shall not impact other systems and/or structures falling within its physical sphere of influence.

Comment: it is not acceptable for the ADT system to interfere with other aircraft systems and/or structures. Its installation is not to increase the aircraft's exposure to risks.

Recommendation # 8: it is recommended that the ADT system equipment function in both pressurized and non-pressurized aircraft zones.

Comment: This recommendation grants the aircraft OEM more installation options for the ADT system.

3.8.1.6 Maintenance, system health monitoring and fault isolation

Requirement # 2: ADT system installation maintenance errors and their effects should have no safety effect on the aircraft and its systems.

Comment: it is not acceptable that maintenance errors associated with the ADT system affect the safety of the flight. Its installation is not to increase the aircraft's exposure to risks.

Recommendation # 9: it is recommended that the ADT system presents a Built-In Test Equipment (BITE) capability.

Comment: A BITE is characterized primarily as a self-test feature built into the airborne component system as a passive fault indicator. Some of the functions or capabilities of BITE include the following: system status and malfunction verification; degraded capabilities status; continuous operation monitoring, etc. Therefore, it is recommended for the ADT system to be monitored to determine if it has failed or is operating in a degraded mode (e.g.: the distress event detection logic can only determine unusual attitude and not unusual speed). Timing monitors such as watchdog timers, heartbeat monitors or activity monitors could be used to verify if the ADT system equipment are operating properly.

Recommendation # 10: the aircraft should have a selection to notify the operator if the ADT system has failed or operates with degraded capabilities.

STRAWMAN FOR ARINC PROJECT PAPER 680

Comment: Although the failure or the degraded operation of the ADT system has no safety effect for the aircraft, it is recommended to notify, as practical as possible, the aircraft operator, on the ground, that the ADT system has failed or is operating in a degraded mode.

Recommendation # 11: ADT system faults should be stored and easily retrieved.

Comment: This recommendation aims to facilitate the aircraft operator maintenance actions.

Recommendation # 12: it is recommended that the ADT system presents interface to the aircraft's onboard maintenance system.

Comment: This recommendation aims to facilitate the integration between the ADT system and the aircraft's onboard maintenance system.

3.8.1.7 Particular risk analysis: fire

Recommendation # 13: it is recommended that the ADT system equipment do not contain flammable material.

Comment: This recommendation is addresses the particular risk of fire, to assure that if the ADT system is subjected to it, then it will not support a sustained fire.

3.8.1.8 Software considerations

Recommendation # 14: it is recommended that the "Distress Event Detection" and "Triggering Criteria Logic" Blocks are configured via Parameter Data Items - PDI - (configuration file(s)) to influence the behavior of the software without modifying the executable object code.

Comment: This recommendation aims to facilitate the ADT system development and certification. Since it is required for the ADT system to present less than 1 nuisance report per 100,000 flight hours², it is expected that several adjustments to the "Distress Event Detection" and "Triggering Criteria Logic" will be necessary along the development and certification campaigns. And it would be extremely helpful if these adjustments could be performed without software (executable object code) modification.

Recommendation # 15: it is recommended for the software of the items of the ADT system to be field-loadable.

Comment: This recommendation intends to facilitate the deployment and update of the ADT system in the field.

² Item 3.2.4 of ED-237: Minimum Aviation System Performance Specification for Criteria to Detect In-Flight Aircraft Distress Events to Trigger Transmission of Flight Information; EUROCAE, Feb 2016.

STRAWMAN FOR ARINC PROJECT PAPER 680

4.0 Summary and Conclusions

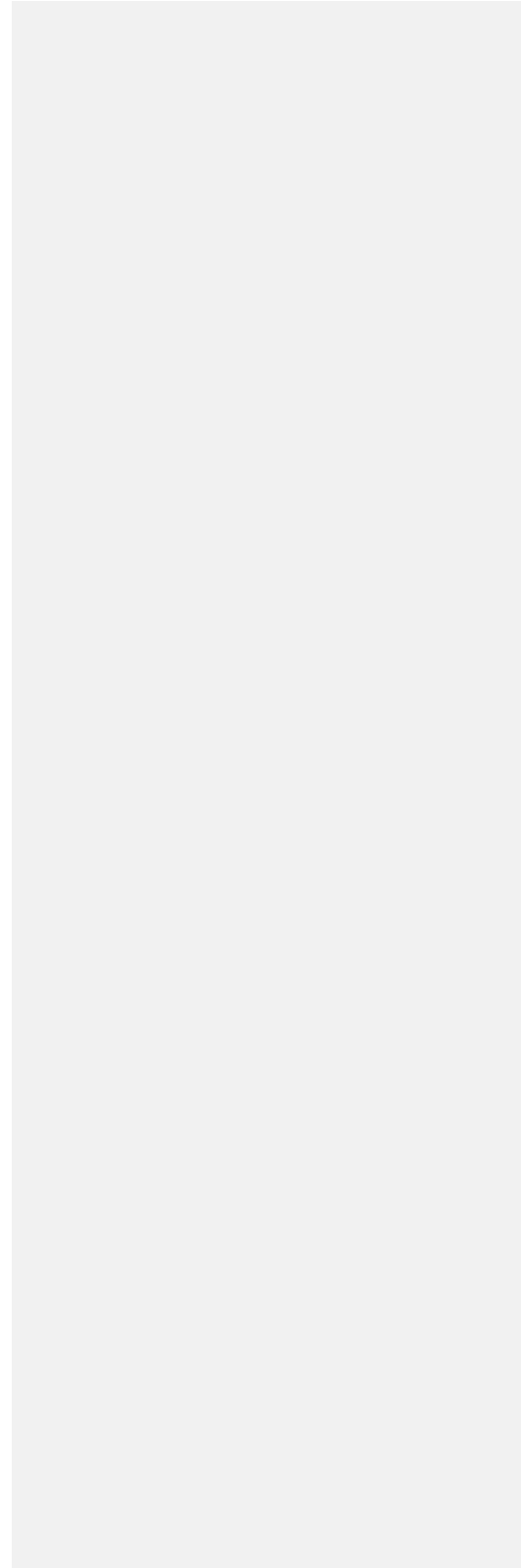

STRAWMAN FOR ARINC PROJECT PAPER 680

5.0 Acronyms

ADS-B – Automatic Dependent Surveillance – Broadcast

ACARS – Aircraft Communications Addressing and Reporting System

ADT – Autonomous Distress Tracking

App – Approach

ELT – Emergency Locator Transmitter

GA – Go-Around

HF – High Frequency

M – Mach Number

M_{MO} – Maximum Operating Mach Number

N_1 – rotor speed of the low-pressure rotor

N_2 – rotor speed of the high-pressure rotor

SATCOM – Satellite Communication

TAWS – Terrain Alert and Warning System

TO – Take-Off

V_{FE} – Maximum Flap Extended Speed

VHF – Very High Frequency

V_{MO} – Maximum Operating Speed

v_z – Vertical Speed

WFE – Engine Fuel Flow

α – angle of attack

ϕ – roll angle

STRAWMAN FOR ARINC PROJECT PAPER 680

$\dot{\phi}$ – roll angle rate

θ – pitch angle

$\dot{\theta}$ – pitch angle rate

ψ – yaw angle

$\dot{\psi}$ – yaw angle rate

STRAWMAN FOR ARINC PROJECT PAPER 680

Appendix A ADT Requirements Summaries, Analyses and Discussion

A.1 ICAO Requirements

The ICAO requirements that apply to ADT are contained in different ICAO documents, and are documented within the following sub-sections.

A.1.1 ICAO Annex 6

The ICAO Annex 6 requirements that apply to ADT are documented in the following table. The section number refers to the section within ICAO Annex 6.

Table 5: Annex 6 AIRCRAFT TRACKING Requirements.

Annex 6 Section	Annex 6 Requirement	GADSS CONOPS Requirement	Comparison of Annex 6 vs GADSS CONOPS Requirements, Notes, Comments, Questions
3.5	AIRCRAFT TRACKING	3.1 Aircraft Tracking Function	Amendment 42 Applicable on and after 8 November 2018
3.5.1	The operator shall establish an aircraft tracking capability to track aeroplanes throughout its area of operations	<p>3.1.1 The aircraft tracking function will leverage existing technologies to support SAR by:</p> <ul style="list-style-type: none"> - Assisting in the timely identification and location of aircraft; - Reducing the reliance on the procedural methods used for determining aircraft position; - Helping to ensure the availability and sharing of aircraft position data (with the relevant entities); and - Helping to improve the effectiveness, efficiency and performance of ATS Unit Alerting. <p>3.1.2 Aircraft operators may meet the requirements of the Aircraft Tracking function using available and planned technologies as deemed effective.</p> <p>In general terms the Aircraft Tracking function:</p>	Basic capability throughout area of operations

STRAWMAN FOR ARINC PROJECT PAPER 680

Annex 6 Section	Annex 6 Requirement	GADSS CONOPS Requirement	Comparison of Annex 6 vs GADSS CONOPS Requirements, Notes, Comments, Questions
		<ul style="list-style-type: none"> - Does not introduce any change to current ATC Alerting procedures; - Establishes operator responsibilities for tracking based on areas of operation; - is not technology-specific; - Establishes communication protocols between operator and ATC. <p>3.1.5 When the tracking is performed by the aircraft operator and the specific technology utilised by the aircraft operator has the capability, the reporting rate could be increased in response to abnormal events.</p>	
Note	Guidance on aircraft tracking capabilities is contained in the Aircraft Tracking Implementation Guidelines (Cir 347).		Circular 347 provides extensive information on implementing flight following/tracking and could have significant potential applicability to distress tracking processes as well.
3.5.2	Recommendation.— The operator should track the position of an aeroplane through automated reporting at least every 15 minutes for the portion(s) of the in-flight operation(s) under the following conditions:	3.1.1 ...To achieve these aims, the Aircraft Tracking function will provide an automated 4 dimensional position (4D – latitude, longitude, altitude and time) at a reporting interval of 15 minutes or less (recommended in all areas of operation and required in oceanic areas). This reporting interval will ultimately reduce the time necessary to resolve the status of an aircraft or when necessary, help to locate an aircraft.	Automated 15 min position reports

STRAWMAN FOR ARINC PROJECT PAPER 680

Annex 6 Section	Annex 6 Requirement	GADSS CONOPS Requirement	Comparison of Annex 6 vs GADSS CONOPS Requirements, Notes, Comments, Questions
a.)	the aeroplane has a maximum certificated take-off mass of over 27 000 kg and a seating capacity greater than 19; and		
b.)	where an ATS unit obtains aeroplane position information at greater than 15 minute intervals.	3.1.3 The aircraft tracking function requires the aircraft operator to ensure that the aircraft is tracked when ATS surveillance services obtain an aircraft position at greater than 15 minute intervals. Having confirmed the air traffic services obtain an aircraft position at 15 minute intervals or less, an aircraft operator does not need to track the aircraft.	If ANSP position tracks are at > 15 min intervals
Note	See Annex 11, Chapter 2, for coordination between the operator and air traffic services providers regarding position report messages		
3.5.3	The operator shall track the position of an aeroplane through automated reporting at least every 15 minutes for the portion(s) of the in-flight operation(s) that is planned in an oceanic area(s) under the following conditions:	3.1.1 ...To achieve these aims, the Aircraft Tracking function will provide an automated 4 dimensional position (4D – latitude, longitude, altitude and time) at a reporting interval of 15 minutes or less (recommended in all areas of operation and required in oceanic areas). This reporting interval will ultimately reduce the time necessary to resolve the status of an aircraft or when necessary, help to locate an aircraft. 3.1.5 When the tracking is performed by the aircraft operator and the specific technology utilised by the aircraft operator has the capability, the reporting rate	Basic capability for oceanic operations, Automated 15 min position reports Potential for abnormal event detection with higher rate reporting.

STRAWMAN FOR ARINC PROJECT PAPER 680

Annex 6 Section	Annex 6 Requirement	GADSS CONOPS Requirement	Comparison of Annex 6 vs GADSS CONOPS Requirements, Notes, Comments, Questions
		could be increased in response to abnormal events.	
a.)	the aeroplane has a maximum certificated take-off mass of over 45 500 kg and a seating capacity greater than 19; and		
b.)	where an ATS unit obtains aeroplane position information at greater than 15 minute intervals.	<p>3.1.3 The aircraft tracking function requires the aircraft operator to ensure that the aircraft is tracked when ATS surveillance services obtain an aircraft position at greater than 15 minute intervals. Having confirmed the air traffic services obtain an aircraft position at 15 minute intervals or less, an aircraft operator does not need to track the aircraft.</p> <p>3.1.4 To enable aircraft operators to determine where they need to track their aircraft, ANSPs will make available details of the air traffic services surveillance capabilities provided in their area of responsibility. For aircraft a) operating in areas where there is no aircraft tracking function availability, b) for temporary operations outside the normal area of operation or c) for specific flights where the aircraft tracking capability may be unserviceable; an aircraft operator may conduct the flight based on a risk assessment acceptable to the State of Operator.</p>	<p>If ANSP position tracks are at > 15 min intervals</p> <p>ANSPs should make coverage information available, including transient coverage changes.</p>

STRAWMAN FOR ARINC PROJECT PAPER 680

Annex 6 Section	Annex 6 Requirement	GADSS CONOPS Requirement	Comparison of Annex 6 vs GADSS CONOPS Requirements, Notes, Comments, Questions
Note 1	Oceanic area, for the purpose of aircraft tracking, is the airspace which overlies waters outside the territory of a State.		
Note 2	See Annex 11, Chapter 2, for coordination between the operator and air traffic services providers regarding position report messages		
3.5.4	Notwithstanding the provisions in 3.5.2 and 3.5.3, the State of the Operator may, based on the results of an approved risk assessment process implemented by the operator, allow for variations to automated reporting intervals. The process shall demonstrate how risks to the operation, resulting from such variations, can be managed and shall include at least the following:	3.1.1. ...The State of the operator may, based on the results of an approved risk assessment process implemented by the operator, allow for variations to the minimum automated reporting intervals. The process will demonstrate how risks to the operation resulting from such variations can be managed.	Risk based variation allowable by state of operator – risk factors to consider are enumerated.
a.)	capability of the operator's operational control systems and processes, including those for contacting ATS units;		
b.)	overall capability of the aeroplane and its systems;		
c.)	available means to determine the position of, and communicate with, the aeroplane;		

STRAWMAN FOR ARINC PROJECT PAPER 680

Annex 6 Section	Annex 6 Requirement	GADSS CONOPS Requirement	Comparison of Annex 6 vs GADSS CONOPS Requirements, Notes, Comments, Questions
d.)	frequency and duration of gaps in automated reporting;		
e.)	human factors consequences resulting from changes to flight crew procedures; and		This could potentially include implications of increased work load and reduction of crew margins due to ADT function and also potential for crew emergency response activity to inadvertently disable ADT capability
f.)	specific mitigation measures and contingency procedures.		
Note	Guidance on development, implementation and approval of the risk assessment process, which allows for variations to the need for automatic reporting and the required interval, including variation examples, is contained in the Aircraft Tracking Implementation Guidelines (Cir 347).		Circular 347 provides extensive information on implementing flight following/tracking and could have significant potential applicability to distress tracking processes as well.
3.5.3	The operator shall establish procedures, approved by the State of the Operator, for the retention of aircraft tracking data to assist SAR in determining the last known position of the aircraft.	3.1.6 Aircraft operators who receive tracking information directly from the aircraft will ensure that procedures, including communications with ANSP and SAR as per ICAO Annex 11, are in place to respond to instances of missed reporting.	Similar to distress tracking, the normal tracking responsibility is allocated to the operator.

STRAWMAN FOR ARINC PROJECT PAPER 680

Annex 6 Section	Annex 6 Requirement	GADSS CONOPS Requirement	Comparison of Annex 6 vs GADSS CONOPS Requirements, Notes, Comments, Questions
Note	Refer to 4.2.1.3.1 for operator responsibilities when using third parties for the conduct of aircraft tracking under 3.5.	Aircraft Tracking Service Providers 3.1.7 The responsibility to track an aircraft lies with the aircraft operator, however, the service can be provided by a third party contracted by the aircraft operator through a formal agreement. The formal agreement will not allow the transfer of responsibility. 3.1.8 The aircraft operator is responsible for ensuring the aircraft tracking service provider records the aircraft tracking information. The full record will be kept for a duration defined by the State of the operator. 3.1.9 During any identified emergency phase the service provider makes available, at defined intervals, a log with the position of the aircraft and other information relevant to the emergency phase.	
4.6	DUTIES OF FLIGHT OPERATIONS OFFICER/FLIGHT DISPATCHER		
4.6.1	Flight ops officer/flight dispatcher shall notify ATS when aeroplane position cannot be determined by tracking and attempts to establish communication are unsuccessful	3.1.6 Aircraft operators who receive tracking information directly from the aircraft will ensure that procedures, including communications with ANSP and SAR as per ICAO Annex 11, are in place to respond to instances of missed reporting.	This is not a distress condition that is detected by aircraft based system

Table 6: Annex 6 LOCATION OF AN AEROPLANE IN DISTRESS Requirements.

STRAWMAN FOR ARINC PROJECT PAPER 680

Annex 6 Section	Annex 6 Requirement	GADSS CONOPS Requirement	Comparison of Annex 6 vs GADSS CONOPS Requirements, Notes, Comments, Questions
6.18	LOCATION OF AN AEROPLANE IN DISTRESS	3.2 Autonomous Distress Tracking Function	
6.18.1	All aeroplanes of a maximum certificated take-off mass of over 27,000 kg for which the individual certificate of airworthiness is first issued on or after 1 January 2021, shall autonomously transmit information from which a position can be determined by the operator at least once every minute, when in distress, in accordance with Appendix 9.	<p>3.2.2 The ADT function uses on board systems to broadcast aircraft position (latitude and longitude), or distinctive distress signals from which the aircraft position and time can be derived. The aircraft position information will be transmitted, without the need for flight crew action, at least once every minute, when an aircraft is in a distress condition. An aircraft is in a distress condition when it is in a state that, if the aircraft behaviour event is left uncorrected, may result in an accident.</p> <p>Note: it is desirable that the aircraft position provided by the ADT also include altitude information. Likewise, the ability to identify the location of the accident site to within 6 NM may be further improved by increasing the frequency of transmission of aircraft position information.</p>	<p>Key requirements: medium or larger aircraft, Jan 1 2021 applicability, distress tracking, operator responsibility to determine position and distress,</p> <p>No retrofit requirement</p> <p>Note; 27K kg is approximately Bombardier Q400 class aircraft and up (Many aircraft in FAA Large category/ICAO Medium category) Ref: https://en.wikipedia.org/wiki/List_of_airlines_by_maximum_take_off_weight</p> <p>Operator responsibility</p>
6.18.2	<i>Recommendation.— All aeroplanes of a maximum certificated take-off mass of over 5,700 kg for which the individual certificate of airworthiness is first issued on or after 1 January 2021, should autonomously</i>		<p>Recommendation for smaller aircraft implementing ADT.</p> <p>No retrofit recommendation for smaller aircraft</p>

STRAWMAN FOR ARINC PROJECT PAPER 680

Annex 6 Section	Annex 6 Requirement	GADSS CONOPS Requirement	Comparison of Annex 6 vs GADSS CONOPS Requirements, Notes, Comments, Questions
	<i>transmit information from which a position can be determined at least once every minute, when in distress, in accordance with Appendix 9.</i>		
6.18.3	The operator shall make position information of a flight in distress available to the appropriate organizations, as established by the State of the Operator. <i>Note. — Refer to 4.2.1.3.1 for operator responsibilities when using third parties.</i>	3.2.4 The operator will be notified (directly or indirectly) when one of their aircraft is in a distress condition. The ADT function will need to include the capability to deliver the distress tracking information to SAR Agencies.	Key requirement: operator responsibility
4.2.1.3.1	The operator shall develop policies and procedures for third parties that perform work on its behalf.		
Appdx 9	LOCATION OF AN AEROPLANE IN DISTRESS <i>(Chapter 6, 6.18, refers)</i>		
Appdx 9 1	Location of an aeroplane in distress aims at establishing, to a reasonable extent, the location of an accident site within a 6 NM radius.	3.2.1 The Autonomous Distress Tracking (ADT) function will be used to identify the location of an aircraft in distress with the aim of establishing, to a reasonable extent, the location of an accident site within a 6 NM radius.	
Appdx 9 2.1	An aeroplane in distress shall automatically activate the transmission of information from which its position can be determined by the operator and the position information shall contain a time stamp. It shall also be possible for	3.2.3 In terms of the autonomy, the ADT function will transmit as long as practically possible during the distress condition. “As practically possible” refers to a means to achieve resilience to failures of the aircrafts’ electrical power, navigation and	

STRAWMAN FOR ARINC PROJECT PAPER 680

Annex 6 Section	Annex 6 Requirement	GADSS CONOPS Requirement	Comparison of Annex 6 vs GADSS CONOPS Requirements, Notes, Comments, Questions
	<p>this transmission to be activated manually. The system used for the autonomous transmission of position information shall be capable of transmitting that information in the event of aircraft electrical power loss, at least for the expected duration of the entire flight.</p> <p><i>Note.— Guidance on the location of an aeroplane in distress is provided in Attachment K.</i></p>	<p>communication systems as well as to human factors. The onboard component of the ADT function will be designed such that, in the event of aircraft electrical power loss, it will continue transmitting for the expected duration of the remaining flight.</p>	
<p>Appdx 9 2.2</p>	<p>An aircraft is in a distress condition when it is in a state that, if the aircraft behaviour event is left uncorrected, can result in an accident. Autonomous transmission of position information shall be active when an aircraft is in a distress condition. This will provide a high probability of locating an accident site to within a 6 NM radius. The operator shall be alerted when an aircraft is in a distress condition with an acceptable low rate of false alerts. In case of a triggered transmission system, initial transmission of position information shall commence immediately or no later than five seconds after the detection of the activation event.</p>	<p>3.2.5 To identify a distress condition, the aircraft state will be analysed in real-time by aircraft systems or ground processes and the use of event detection and triggering criteria logic will initiate the notification of the alert to assist locating the aircraft in distress. Distress tracking is a combination of position reporting at intervals of one minute or less with a notification of distress. The event detection and triggering can be used to identify a distress condition (for a system that is already transmitting aircraft position information), or to notify a distress condition and also commence transmitting of aircraft position information. Distress tracking manually initiated by the flight crew should also generate a notification.</p>	

STRAWMAN FOR ARINC PROJECT PAPER 680

Annex 6 Section	Annex 6 Requirement	GADSS CONOPS Requirement	Comparison of Annex 6 vs GADSS CONOPS Requirements, Notes, Comments, Questions
	<p><i>Note 1. — Aircraft behaviour events can include, but are not limited to, unusual attitudes, unusual speed conditions, collision with terrain and total loss of thrust/propulsion on all engines and ground proximity warnings.</i></p> <p><i>Note 2. — A distress alert can be triggered using criteria that may vary as a result of aircraft position and phase of flight. Further guidance regarding in-flight event detection and triggering criteria may be found in the EUROCAE ED-237, Minimum Aviation System Performance Specification (MASPS) for Criteria to Detect In-Flight Aircraft Distress Events to Trigger Transmission of Flight Information.</i></p>	<p>3.2.5.1 The triggering criteria may include analysis of unusual attitudes, unusual altitudes, unusual speeds, potential collision with terrain, total loss of thrust/propulsion on all engines, Mode A squawk codes, etc. The triggers will be defined making sure that the criteria used maximises the probability of detection of an upcoming catastrophic event.</p> <p>3.2.5.2 In the case of an on-board triggered transmission system (distinctive distress signal), initial transmission of aircraft position information shall commence immediately or no later than five seconds after the detection of the distress condition.</p> <p>Note: Further guidance regarding in-flight event detection and triggering criteria may be found in the EUROCAE ED-237 Minimum Aviation Performance Specification (MASPS) for Criteria to Detect In-Flight Aircraft Distress Events to Trigger Transmission of Flight Information.</p> <p>3.2.8 In case of recovery from the distress condition, distress tracking and any distress signal will be deactivated. However, the deactivation will only be possible using the activating mechanism.</p> <p>3.2.9 A functionality to allow the aircraft operator to activate the ADT function could be included,</p>	

STRAWMAN FOR ARINC PROJECT PAPER 680

Annex 6 Section	Annex 6 Requirement	GADSS CONOPS Requirement	Comparison of Annex 6 vs GADSS CONOPS Requirements, Notes, Comments, Questions
		for example, when there is uncertainty about the status of the aircraft and attempts to establish communications with the flight crew have failed.	
Appdx 9 2.3	When an aircraft operator or an air traffic service unit (ATSU) has reason to believe that an aircraft is in distress, coordination shall be established between the ATSU and the aircraft operator.	3.2.4 The operator will be notified (directly or indirectly) when one of their aircraft is in a distress condition. The ADT function will need to include the capability to deliver the distress tracking information to SAR Agencies.	
Appdx 9 2.4	<p>The State of the Operator shall identify the organizations that will require the position information of an aircraft in an emergency phase. These shall include, as a minimum:</p> <ul style="list-style-type: none"> a) air traffic service unit(s) (ATSU); and b) SAR rescue coordination centre(s) (RCC) and sub-centres. <p><i>Note 1. — Refer to Annex 11 for emergency phase criteria.</i></p> <p><i>Note 2. — Refer to Annex 12 for required notifications in the event of an emergency phase.</i></p>		
Appdx 9 2.5	When autonomous transmission of position information has been activated, it shall only be able to be deactivated using the same mechanism that activated it.	3.2.8 In case of recovery from the distress condition, distress tracking and any distress signal will be deactivated. However, the deactivation will only be possible using the activating mechanism.	

STRAWMAN FOR ARINC PROJECT PAPER 680

Annex 6 Section	Annex 6 Requirement	GADSS CONOPS Requirement	Comparison of Annex 6 vs GADSS CONOPS Requirements, Notes, Comments, Questions
Appdx 9 2.6	The accuracy of position information shall, as a minimum, meet the position accuracy requirements established for ELTs.		
Attach K	ATTACHMENT K. LOCATION OF AN AEROPLANE IN DISTRESS <i>(Supplementary to Chapter 6, 6.18)</i> GUIDANCE FOR LOCATION OF AN AEROPLANE IN DISTRESS		
Attach K 1	INTRODUCTION		
	The following material provides guidance on locating an aeroplane in distress. The Triggered Transmission of Flight Data Working Group (TTFDWG) reviewed forty-two accidents to determine an indication of the distance from a last-known aeroplane position to the location of an accident site. The report concluded that in approximately 95 per cent of the cases, when the aircraft position was known one minute prior to the accident, the accident site location was within a 6 NM radius of that position.		Discussion of the derivation of the 1/min reporting rate requirement.

STRAWMAN FOR ARINC PROJECT PAPER 680

Annex 6 Section	Annex 6 Requirement	GADSS CONOPS Requirement	Comparison of Annex 6 vs GADSS CONOPS Requirements, Notes, Comments, Questions
Attach K 1.2	<p>When an aeroplane has an accident into water and becomes submerged, the location of the accident site within a 6 NM radius on the surface becomes more important. Starting the initial search area beyond a 6 NM radius reduces the amount of time available to search for and locate the aeroplane. At current estimated underwater search capabilities of 100 km²/day, an area with a 6 NM radius could be searched in four days. Allowing for naval assets to reach the search area and conduct the search, it is estimated that an area of 2 300 km², equivalent to a radius of 14 NM, will be able to be searched before the ULD battery degrades. Starting at an area of more than 6 NM radius reduces the probability of a successful location during an initial search, whilst extending the location requirement beyond 6 NM radius reduces the time available to search with no appreciable gain in the probability of recovery.</p>		Discussion of the significance of the 6 NM radius in the search and recovery chain.
Attach K 2.	CLARIFICATION OF PURPOSE OF EQUIPMENT		
Attach K 2.1	Information from which a position can be determined: Information from an aircraft system		Discussion/ clarification of information to be

STRAWMAN FOR ARINC PROJECT PAPER 680

Annex 6 Section	Annex 6 Requirement	GADSS CONOPS Requirement	Comparison of Annex 6 vs GADSS CONOPS Requirements, Notes, Comments, Questions
	<p>which either is active, or, when automatically or manually activated, can provide position information which includes a time stamp. This is a performance-based requirement which is not system-specific and may also bring operational benefits.</p>		<p>transmitted in a distress condition</p>
<p>Attach K 2.2</p>	<p>Emergency locator transmitter (ELT): The current generation of ELTs were designed to provide the position of impact for a survivable accident. The next generation of ELTs may have the capability to activate a transmission in flight when any of the conditions detailed in EUROCAE ED-237, Minimum Aviation System Performance Specification (MASPS) for Criteria to Detect In-Flight Aircraft Distress Events to Trigger Transmission of Flight Information are met. When an ELT sinks below the surface of water, its signal is not detectable.</p>		<p>Discussion of background of current ELT systems and the expected ELT-DT capabilities</p>
<p>Attach K 2.3</p>	<p>Automatic deployable flight recorder (ADFR): The purpose of an ADFR is to have flight recorder data available soon after an accident, in particular for accidents over water. The integrated ELT provides for both locating the accident site for accident</p>		<p>Discussion of background of automatically deployable flight data recorders</p>

STRAWMAN FOR ARINC PROJECT PAPER 680

Annex 6 Section	Annex 6 Requirement	GADSS CONOPS Requirement	Comparison of Annex 6 vs GADSS CONOPS Requirements, Notes, Comments, Questions
	investigation and search and rescue purposes. Being floatable, it will assist in locating the accident site by providing an ELT signal when the wreckage sinks below the surface of the water. It also ensures redundancy for one ELT.		
Attach K 2.4	Underwater locator device (ULD): A ULD operating at a frequency of 8.8 kHz is attached to the airframe to locate aeroplane wreckage below the surface of water when an ELT signal is not possible to detect. The ULDs operating at 37.5 kHz are attached to the flight recorders and are used for locating the flight recorders under water.		Background - Discussion of LF-ULD and ULB capability and intended use.
Attach K 3	EQUIPAGE COMPLIANCE		
	The advancement of technology has made it possible to meet the equipage requirements by different means. Table K-1 below provides examples of compliance. In such potential installations, the cost will be minimized and the effectiveness of the current installation improved.		
Table K-1.	Examples of compliance		

STRAWMAN FOR ARINC PROJECT PAPER 680

Annex 6 Section	Annex 6 Requirement	GADSS CONOPS Requirement	Comparison of Annex 6 vs GADSS CONOPS Requirements, Notes, Comments, Questions
Current/in-Service	Two ELTs Two fixed recorders		Current equipment requirements.
After 1 January 2021/ Application for type certification is submitted to a Contracting State	Example: A system from which a position can be determined; and one ADFR with an integrated ELT; and one combined recorder; or A system from which a position can be determined and one ELT and two fixed recorders and an additional means to retrieve flight recorder data in a timely manner		An example where the existing equipment is replaced by an ADT, an ADFR and a combined recorder or another example where the existing equipment is replaced by an ADT, an ELT and two fixed recorders and a means to recover the FDR data in a timely manner (for example a suitable flight data streaming capability)
Note	A system from which a position can be determined and used to comply with Chapter 6, 6.18, may replace one of the ELTs required by Chapter 6, 6.17		Reiteration that an ADT is an allowable replacement for an ELT

A.1.2 ICAO Annex 11

The ICAO Annex 11 requirements that may apply or be impacted by ADT capabilities are documented in the following table. Annex 11 has not been specifically updated to reflect ADT implementation so this table compares the Annex 11 requirements with related GADSS CONOPS sections and discusses differences and potential gaps or support for the Annex 11 requirements. The section number refers to the section within ICAO Annex 11.

Table 7: Annex 11 Requirements and Comparison with GADSS CONOPS.

STRAWMAN FOR ARINC PROJECT PAPER 680

Annex 11 Section	Annex 11 Requirement	GADSS CONOPS Requirement	Comparison of Annex 11 vs GADSS CONOPS Requirements, Notes, Comments, Questions
CHAPTER 1. DEFINITIONS	<i>Emergency phase.</i> A generic term meaning, as the case may be, uncertainty phase, alert phase or distress phase.		No difference with respect to GADSS CONOPS
	<i>Alert phase.</i> A situation wherein apprehension exists as to the safety of an aircraft and its occupants.		No difference with respect to GADSS CONOPS
	<i>Distress phase.</i> A situation wherein there is reasonable certainty that an aircraft and its occupants are threatened by grave and imminent danger or require immediate assistance.		No difference with respect to GADSS CONOPS
		<p>Varying Uses of the word Distress throughout Annexes and the CONOPS that are not defined in Annex 11 DISTRESS CONDITION</p> <p>Annex 6 Appendix 9 2.2 An aircraft is in a distress condition when it is in a state that, if left uncorrected, can result in an accident.</p> <p>CONOPS 3.2.2 An aircraft is in a distress condition when it is in a state that, if the aircraft behaviour event is left uncorrected, may result in an accident</p>	This is discussed in detail in section 2.3.2.3.

STRAWMAN FOR ARINC PROJECT PAPER 680

Annex 11 Section	Annex 11 Requirement	GADSS CONOPS Requirement	Comparison of Annex 11 vs GADSS CONOPS Requirements, Notes, Comments, Questions
		<p>CONOPS 3.2.5 To identify a distress condition, the aircraft state will be analysed in real-time by aircraft systems or ground processes and the use of event detection and triggering criteria logic will initiate the notification of the alert to assist locating the aircraft in distress.</p> <p>Distress tracking is a combination of position reporting at intervals of one minute or less with a notification of distress.</p> <p>DISTRESS Annex 6 app 9, 2.3 When an aircraft operator or an air traffic service unit (ATSU) has reason to believe that an aircraft is in distress, coordination shall be established between ATSU and the Aircraft operator</p>	
	<p>Uncertainty phase. A situation wherein uncertainty exists as to the safety of an aircraft and its occupants.</p>		<p>No difference with respect to GADSS CONOPS</p>
	<p>Alerting Service A service provided to notify appropriate organizations regarding aircraft in need of search and rescue aid, and assist such organizations as required.</p>		

STRAWMAN FOR ARINC PROJECT PAPER 680

Annex 11 Section	Annex 11 Requirement	GADSS CONOPS Requirement	Comparison of Annex 11 vs GADSS CONOPS Requirements, Notes, Comments, Questions
<p>2.2 Objectives of the air traffic services</p>	<p>The objectives of the air traffic services shall be to:</p> <ul style="list-style-type: none"> a) prevent collisions between aircraft; b) prevent collisions between aircraft on the manoeuvring area and obstructions on that area; c) expedite and maintain an orderly flow of air traffic; d) provide advice and information useful for the safe and efficient conduct of flights; e) notify appropriate organizations regarding aircraft in need of search and rescue aid, and assist such organizations as required. 	<p>CONOPS: 2.0 High Level Objectives of the GADSS</p> <p>2.1 The GADSS is designed to address three specific issues;</p> <ul style="list-style-type: none"> a) the late notification of SAR services when aircraft are in distress (as defined in ICAO Annex 11), b) missing or inaccurate end of flight aircraft position information i.e. the location of wreckage and c) lengthy and costly retrieval of flight data for accident investigation. <p>2.2 The consequent objectives of the GADSS are:</p> <ul style="list-style-type: none"> • Ensure timely detection of aircraft in distress • To timely initiate SAR actions • Ensure tracking of aircraft in distress and timely and accurate location of end of flight • To accurately direct SAR actions • Enable efficient and effective SAR operations • Ensure timely retrieval of Flight Recorder Data 	<p>These differences reflect the broader scope of Annex 11 which addresses services well beyond those just covering aircraft in distress conditions.</p> <p>Annex 11 objective e.) is the area that is aligned with and addressed by the GADSS capabilities.</p>
<p>2.3 Divisions of the air traffic services</p>	<p>The air traffic services shall comprise three services identified as follows.</p> <p>2.3.1 The <i>air traffic control service</i>, to accomplish</p>		<p>No direct GADSS equivalent; these differences reflect the broader scope of Annex 11 which addresses services</p>

STRAWMAN FOR ARINC PROJECT PAPER 680

Annex 11 Section	Annex 11 Requirement	GADSS CONOPS Requirement	Comparison of Annex 11 vs GADSS CONOPS Requirements, Notes, Comments, Questions
	<p>objectives a), b) and c) of 2.2, this service being divided in three parts as follows:</p> <p><i>a) Area control service:</i> the provision of air traffic control service for controlled flights, except for those parts of such flights described in 2.3.1 b) and c), in order to accomplish objectives a) and c) of 2.2;</p> <p><i>b) Approach control service:</i> the provision of air traffic control service for those parts of controlled flights associated with arrival or departure, in order to accomplish objectives a) and c) of 2.2;</p> <p><i>c) Aerodrome control service:</i> the provision of air traffic control service for aerodrome traffic, except for those parts of flights described in 2.3.1 b), in order to accomplish objectives a), b) and c) of 2.2.</p> <p>2.3.2 The <i>flight information</i> service, to accomplish objective d) of 2.2.</p>		<p>well beyond those just covering aircraft in distress conditions</p>
	<p>2.3.3 The alerting service, to accomplish objective e) of 2.2.</p> <p>(2.2 e) notify appropriate organizations regarding aircraft in need of search</p>	<p>Covered in CONOPS CONOPS 2.2 The consequent objectives of the GADSS are:</p> <ul style="list-style-type: none"> • Ensure timely detection of aircraft in distress 	<p>Annex 11 alerting service aligns with and is supported by the GADSS capabilities.</p>

STRAWMAN FOR ARINC PROJECT PAPER 680

Annex 11 Section	Annex 11 Requirement	GADSS CONOPS Requirement	Comparison of Annex 11 vs GADSS CONOPS Requirements, Notes, Comments, Questions
	and rescue aid, and assist such organizations as required.)	<ul style="list-style-type: none"> • To timely initiate SAR actions • Ensure tracking of aircraft in distress and timely and accurate location of end of flight • To accurately direct SAR actions • Enable efficient and effective SAR operations • Ensure timely retrieval of Flight Recorder Data 	
2.24 Service to aircraft in the event of an emergency	2.24.1 An aircraft known or believed to be in a state of emergency, including being subjected to unlawful interference, shall be given maximum consideration, assistance and priority over other aircraft as may be necessitated by the circumstances.		This section reflects ground system responses to an aircraft distress notification. Integration of Air Navigation Services /Air Traffic Control services with distress tracking is addressed in the GADSS CONOPS via data dissemination to and from the distress tracking repository. This aspect would benefit from more development at the SARPS level.
	<p><i>Note. — To indicate that it is in a state of emergency, an aircraft equipped with an appropriate data link capability and/or an SSR transponder might operate the equipment as follows:</i></p> <p><i>a) on Mode A, Code 7700; or</i></p>	Annex 6 App 9 2.1 An aeroplane in distress shall automatically activate the transmission of information from which its position can be determined by the operator and the position information shall contain a time stamp. It shall also be possible for this transmission to be activated	<p>Questions raised:</p> <p>Annex 11 reflects transponder (mode-A) codes and data link (CPDLC) alerts from the aircraft, in the future there should be a revision to Annex 11 addressing “Manual</p>

STRAWMAN FOR ARINC PROJECT PAPER 680

Annex 11 Section	Annex 11 Requirement	GADSS CONOPS Requirement	Comparison of Annex 11 vs GADSS CONOPS Requirements, Notes, Comments, Questions
	<p><i>b) on Mode A, Code 7500, to indicate specifically that it is being subjected to unlawful interference; and/or</i></p> <p><i>c) activate the appropriate emergency and/or urgency capability of ADS-B or ADS-C; and/or</i></p> <p><i>d) transmit the appropriate emergency message via CPDLC.</i></p>	<p>manually. The system used for the autonomous transmission of position information shall be capable of transmitting that information in the event of aircraft electrical power loss, at least for the expected duration of the flight.</p>	<p>activation of the ADT by Flight crew.”</p> <p>Does the aircraft ADT systems need to know when a) b) c) or d of Annex 11 2.24.1 are occurring to that it can start transmitting at 1 minute intervals?</p> <p>With an ADT Trigger systems on ac that detects events, could/should other systems (i.e. transponder) send out corresponding alerts?</p>
<p>2.24.2</p>	<p>When an occurrence of unlawful interference with an aircraft takes place or is suspected, ATS units shall attend promptly to requests by the aircraft. Information pertinent to the safe conduct of the flight shall continue to be transmitted and necessary action shall be taken to expedite the conduct of all phases of the flight, especially the safe landing of the aircraft.</p>		<p>This is not addressed in the CONOPS or the Annex 6 however we are dealing with a potentially uncooperative crew (see requirements scope discussion).</p>
<p>2.24.3</p>	<p>When an occurrence of unlawful interference with an aircraft takes place or is suspected, ATS units shall, in accordance with locally agreed procedures, immediately inform the appropriate authority designated by the State</p>		<p>Question raised: should the ADT system highlight the possibility of unlawful interference with track deviation. We would need to define the deviation metrics – this can be highly</p>

STRAWMAN FOR ARINC PROJECT PAPER 680

Annex 11 Section	Annex 11 Requirement	GADSS CONOPS Requirement	Comparison of Annex 11 vs GADSS CONOPS Requirements, Notes, Comments, Questions
	<p>and exchange necessary information with the operator or its designated representative.</p> <p>Note 1. — A strayed or unidentified aircraft may be suspected as being the subject of unlawful interference. See 2.25.1.3.</p>		<p>variable (e.g. weather re-routing etc...) is operator specific – not currently covered in requirements.</p> <p>Note: ICAO GADSS has moved away from unlawful interference.</p>
<p>2.25 In-flight contingencies</p>	<p>2.25.1 Strayed or unidentified aircraft</p> <p><i>Note 1. — The terms “strayed aircraft” and “unidentified aircraft” in this paragraph have the following meanings:</i></p> <p>Strayed aircraft. <i>An aircraft which has deviated significantly from its intended track or which reports that it is lost.</i></p> <p>Unidentified aircraft. <i>An aircraft which has been observed or reported to be operating in a given area but whose identity has not been established.</i></p> <p><i>Note 2. — An aircraft may be considered, at the same time, as a “strayed aircraft” by one unit and as an “unidentified aircraft” by another unit.</i></p> <p>Note 3. — A strayed or unidentified aircraft may be suspected as being the</p>		<p>Note 1 - deviated significantly from its intended track</p> <p>Not an ADT requirement. May be covered as part of Annex 6 normal tracking requirements.</p> <p>Should ADT define that or the operator. We need to consider false triggering here. See discussion above on variability.</p> <p>Does ADT need to identify if strayed (deviation from track) and / or Unidentified aircraft (general aircraft communication down/un-responsive) – potentially these could be addressed with ground based ADT activation option – not possible for all architectures.</p>

STRAWMAN FOR ARINC PROJECT PAPER 680

Annex 11 Section	Annex 11 Requirement	GADSS CONOPS Requirement	Comparison of Annex 11 vs GADSS CONOPS Requirements, Notes, Comments, Questions
	<i>subject of unlawful interference.</i>		If note 1 applies, ADT should be triggering at one minute
2.25.1.1.1	<p>If the aircraft's position is not known, the air traffic services unit shall:</p> <p>a) attempt to establish two-way communication with the aircraft, unless such communication already exists;</p> <p>b) use all available means to determine its position;</p> <p>c) inform other ATS units into whose area the aircraft may have strayed or may stray, taking into account all the factors which may have affected the navigation of the aircraft in the circumstances;</p> <p>d) inform, in accordance with locally agreed procedures, appropriate military units and provide them with pertinent flight plan and other data concerning strayed aircraft;</p> <p>e) request from the units referred to in c) and d) and from other aircraft in flight every assistance in establishing communication with the aircraft and determining its position.</p>		<p>Annex 11 addresses ATS action for an aircraft that can't located or communicated with.</p> <p>This is potentially addressed by ADT manual activation on aircraft or from the ground system.</p> <p>The addition of ADT capabilities and data sources such as the distress tracking data repository would be an additional set of tools for ATS to use.</p>

STRAWMAN FOR ARINC PROJECT PAPER 680

Annex 11 Section	Annex 11 Requirement	GADSS CONOPS Requirement	Comparison of Annex 11 vs GADSS CONOPS Requirements, Notes, Comments, Questions
CHAPTER 5. ALERTING SERVICE			
5.1 Application	5.1.1 Alerting service shall be provided: a) for all aircraft provided with air traffic control service; b) in so far as practicable, to all other aircraft having filed a flight plan or otherwise known to the air traffic services; and c) to any aircraft known or believed to be the subject of unlawful interference.	CONOPS 4.1.2 During normal operations, aircraft position information needs to be updated and is available (through ATS surveillance) for ATS unit Alerting Services at least once per 15 min. Where necessary (i.e. automatic position updates of at least once per 15 min cannot be achieved) aircraft operators make use of Aircraft Tracking capabilities. Loss of position updates and communication is detected by the ATS unit and/or the operator. In case the operator detects a loss of position updates it will contact and provide relevant information to the ATS unit to activate and inform the Alerting Service.	The GADSS CONOPS addresses this in terms of loss of the Normal tracking position updates by the operator. This is potentially addressed by ADT manual activation on aircraft or from the ground system. The addition of ADT capabilities and data sources such as the distress tracking data repository would be an additional set of tools for the operator and ATS to use.
	5.1.2 Flight information centres or area control centres shall serve as the central point for collecting all information relevant to a state of emergency of an aircraft operating within the flight information region or control area concerned and for forwarding such information to the appropriate rescue coordination centre.	CONOPS 4.3.5 Flight information centres or area control centres are the first responsible to act as central point for collecting all information relevant to the state of emergency of an aircraft operating in its area of jurisdiction (ref ICAO Annex 11, 5.1.2). Coordination and information sharing agreements and procedures will be established between civil and military authorities to ensure that all possible means and information can be made	GADSS CONOPS refers to distress tracking Repository of information Fig c 3.4.6 But this potentially contradicts CONOPS 4.3.5 which explicitly acknowledges the primary role of the flight information centres. This inconsistency would be addressed by FIC access to the distress tracking data for it's region, via a central repository or from

STRAWMAN FOR ARINC PROJECT PAPER 680

Annex 11 Section	Annex 11 Requirement	GADSS CONOPS Requirement	Comparison of Annex 11 vs GADSS CONOPS Requirements, Notes, Comments, Questions
		available without delay in case of emergency situations.	<p>AOC's or delegated service providers.</p> <p>This seems to imply that the FIC / AC could be between repository and the RCC's which may contradict the CONOPS intent of providing universal and timely access to the distress tracking data to applicable recipients.</p> <p>What does this look like?</p>
	5.1.3 In the event of a state of emergency arising to an aircraft while it is under the control of an aerodrome control tower or approach control unit, such unit shall notify immediately the flight information centre or area control centre responsible which shall in turn notify the rescue coordination centre, except that notification of the area control centre, flight information centre, or rescue coordination centre shall not be required when the nature of the emergency is such that the notification would be superfluous.		Refer to discussion above

STRAWMAN FOR ARINC PROJECT PAPER 680

Annex 11 Section	Annex 11 Requirement	GADSS CONOPS Requirement	Comparison of Annex 11 vs GADSS CONOPS Requirements, Notes, Comments, Questions
	<p>5.1.3.1 Nevertheless, whenever the urgency of the situation so requires, the aerodrome control tower or approach control unit responsible shall first alert and take other necessary steps to set in motion all appropriate local rescue and emergency organizations which can give the immediate assistance required</p>		<p>Various levels of ATC may also need access to the repository and RCC's</p> <p>Air – ground: ground filters on aircraft distress.</p> <p>Distributed system: normal, abnormal and distress messages. ADT messages will need sharing to all systems on the ground. GADSS 6.0 3.4 GADSS</p>
<p>5.2 Notification of rescue coordination centres</p>	<p>5.2.1 Without prejudice to any other circumstances that may render such notification advisable, air traffic services units shall, except as prescribed in 5.5.1, notify rescue coordination centres immediately an aircraft is considered to be in a state of emergency in accordance with the following:</p> <p>(5.5.1 When an area control or a flight information centre decides that an aircraft is in the uncertainty or the alert phase, it shall, when practicable, advise the operator prior to notifying the rescue coordination centre.</p> <p><i>Note.— If an aircraft is in the distress phase, the</i></p>	<p>CONOPS</p> <p>3.1.9 During any identified emergency phase the service provider makes available, at defined intervals, a log with the position of the aircraft and other information relevant to the emergency phase.</p>	<p>Observation: Annex 11 Covers all 3 phases. Uncertainty, Alert, Distress, includes discussion of advising the operator if opportunity is available prior to notifying RCC, the ATC-operator interactions may need more detailing for normal tracking and ADT equipped aircraft and the associated increased operator flight following/tracking responsibilities.</p>

STRAWMAN FOR ARINC PROJECT PAPER 680

Annex 11 Section	Annex 11 Requirement	GADSS CONOPS Requirement	Comparison of Annex 11 vs GADSS CONOPS Requirements, Notes, Comments, Questions
	<p><i>rescue coordination centre has to be notified immediately in accordance with 5.2.1.)</i></p>		
	<p>a) <i>Uncertainty phase</i> when:</p> <p>1) no communication has been received from an aircraft within a period of thirty minutes after the time a communication should have been received, or from the time an unsuccessful attempt to establish communication with such aircraft was first made, whichever is the earlier, or when</p> <p>2) an aircraft fails to arrive within thirty minutes of the estimated time of arrival last notified to or estimated by air traffic services units, whichever is the later, except when no doubt exists as to the safety of the aircraft and its occupants</p>	<p>CONOPS 3.2.9 Autonomous Distress Tracking Function A functionality to allow the aircraft operator to activate the ADT function could be included, for example, when there is uncertainty about the status of the aircraft and attempts to establish communications with the flight crew have failed.</p> <p>CONOPS 4.3.9 At the Uncertainty phase, RCCs will normally engage in actions such as conducting basic notifications, gathering basic information on the aircraft and its flight, plotting the aircraft information on a chart and commencing a communication search to attempt contact with the aircraft by all available means, including via the aircraft operator in case the operator is not already involved (e.g. loss of tracking).</p> <p>A communications search is supplementary to the initial communications checks which should have been completed by ATS or the operator prior to phase declaration. Departure, destination and alternate aerodromes will also normally be alerted.</p>	<p>Question: How does/how should the ADT interact or detect ATS phases? Currently no direct requirement for this.</p> <p>Non Communication or overdue ETA is potentially addressed/supported by ADT manual activation on aircraft or from the ground system.</p> <p>ATS identifies uncertainty phase. Aircraft could travel long way in 30 mins of uncertainty phase.</p> <p>What happens when ATC identifies an uncertainty phase but the ADT or the operator does not? Should there be manual triggering from the ground also – is there communication from the ATC to the AOC to request manual ground trigger (if available) or is there a benefit for manual</p>

STRAWMAN FOR ARINC PROJECT PAPER 680

Annex 11 Section	Annex 11 Requirement	GADSS CONOPS Requirement	Comparison of Annex 11 vs GADSS CONOPS Requirements, Notes, Comments, Questions
			ground trigger capability with ATC?
5.2.1	<p>b) <i>Alert phase</i> when:</p> <p>1) following the uncertainty phase, subsequent attempts to establish communication with the aircraft or inquiries to other relevant sources have failed to reveal any news of the aircraft, or when</p> <p>1) following the uncertainty phase, subsequent attempts to establish communication with the aircraft or inquiries to other relevant sources have failed to reveal any news of the aircraft, or when</p> <p>3) information has been received which indicates that the operating efficiency of the aircraft has been impaired, but not to the extent that a forced landing is likely, except when</p>	<p>CONOPS 4.3.10</p> <p>At the Alert phase, RCCs will start to escalate SAR actions which may include alerting SAR resources such as SAR aircraft and vessels, in case of loss of communications conducting wider enquiries with communications stations which may have received transmissions from the aircraft, checking of potential airports where the aircraft may have diverted, plotting its most probable position and maximum range from the last known position, plotting known aircraft and ships known to be in the vicinity and initiating search planning and calculations.</p>	<p>We aren't even in distress phase yet and SAR's are being activated</p> <p>Should the ADT detect alert phase?</p> <p>Refer to discussion above</p>

STRAWMAN FOR ARINC PROJECT PAPER 680

Annex 11 Section	Annex 11 Requirement	GADSS CONOPS Requirement	Comparison of Annex 11 vs GADSS CONOPS Requirements, Notes, Comments, Questions
	evidence exists that would allay apprehension as to the safety of the aircraft and its occupants, or when		
<p>5.2 Notification of rescue coordination centres</p> <p>5.2.1</p>	<p>c) <i>Distress phase</i> when:</p> <p>1) following the alert phase, further unsuccessful attempts to establish communication with the aircraft and more widespread unsuccessful inquiries point to the probability that the aircraft is in distress, or when</p> <p>2) the fuel on board is considered to be exhausted, or to be insufficient to enable the aircraft to reach safety, or when</p> <p>3) information is received which indicates that the operating efficiency of the aircraft has been impaired to the extent that a forced landing is likely, or when</p>	<p>CONOPS 3.2.4 The operator will be notified (directly or indirectly) when one of their aircraft is in a distress condition. The ADT function will need to include the capability to deliver the distress tracking information to SAR Agencies.</p> <p>CONOPS 3.2.5 To identify a distress condition, the aircraft state will be analysed in real-time by aircraft systems or ground processes and the use of event detection and triggering criteria logic will initiate the notification of the alert to assist locating the aircraft in distress. Distress tracking is a combination of position reporting at intervals of one minute or less with a notification of distress. The event detection and triggering can be used to identify a distress condition (for a system that is already transmitting aircraft position information), or to notify a distress condition and also commence transmitting of aircraft position information. Distress tracking manually initiated by the flight crew</p>	<p>Should the ADT detect distress phase as per ATS definition. See above discussions.</p> <p>Do/should Ground processes fall under ED237. At least false alert rate at input to RCC is applicable.</p> <p>What std's cover the ground capabilities?</p>

STRAWMAN FOR ARINC PROJECT PAPER 680

Annex 11 Section	Annex 11 Requirement	GADSS CONOPS Requirement	Comparison of Annex 11 vs GADSS CONOPS Requirements, Notes, Comments, Questions
	<p>4) information is received or it is reasonably certain that the aircraft is about to make or has made a forced landing, except when there is reasonable certainty that the aircraft and its occupants are not threatened by grave and imminent danger and do not require immediate assistance.</p>	<p>should also generate a notification.</p> <p>3.2.5.1 The triggering criteria may include analysis of unusual attitudes, unusual altitudes, unusual speeds, potential collision with terrain, total loss of thrust/propulsion on all engines, Mode A squawk codes, etc. The triggers will be defined making sure that the criteria used maximises the probability of detection of an upcoming catastrophic event.</p> <p>CONOPS 4.3.11 At the Distress phase, RCCs undertake actions with the aim of rapidly locating, assisted by A(D)T information and homing signals, and rescuing survivors. Many concurrent actions will be undertaken including detailed search action planning and dispatch of SAR aircraft and vessels to the planned search area. The search action plan will include on-going development of search plans, allocation and coordination of search assets, a rescue plan, communications plan, intelligence-gathering plan, media response plan and so on, commensurate with the requirements appropriate to the situation.</p> <p>CONOPS 4.3.12 4.3.12 Note that on the initial alert, RCCs may go directly to the Alert or Distress phase if appropriate to the situation and</p>	<p>ADT or operator may not have detected any distress at this point.</p> <p>Manual activation from ground would support potential earlier detection and tracking.</p>

STRAWMAN FOR ARINC PROJECT PAPER 680

Annex 11 Section	Annex 11 Requirement	GADSS CONOPS Requirement	Comparison of Annex 11 vs GADSS CONOPS Requirements, Notes, Comments, Questions
		initiate a SAR response accordingly. For example, a MAYDAY call will immediately trigger Distress phase and the dispatch of SAR units.	
5.2.2	<p>The notification shall contain such of the following information as is available in the order listed:</p> <p>a) INCERFA, ALERFA or DETRESFA, as appropriate to the phase of the emergency;</p> <p>b) agency and person calling;</p> <p>c) nature of the emergency;</p> <p>d) significant information from the flight plan;</p> <p>e) unit which made last contact, time and means used;</p> <p>f) last position report and how determined;</p> <p>h) dangerous goods carried as cargo;</p> <p>i) any action taken by reporting office; and</p> <p>j) other pertinent remarks.</p>		<p>e) Alerting service needs to have the latest reporting position and how it was determined</p> <p>This should be supplied from the repository.</p> <p>j) information in the repository? Altitude? Etc</p> <p>This would be useful for example in a mountainous area to find the impact</p>
	<p>5.2.2.1 Recommendation.— <i>Such part of the information specified in 5.2.2, which is not available at the time notification is made to a rescue coordination centre, should be sought by an air traffic services unit prior to</i></p>		<p>This is supported by the ADT ground based function where ATS will have access to the repository or other distress tracking data sources.</p>

STRAWMAN FOR ARINC PROJECT PAPER 680

Annex 11 Section	Annex 11 Requirement	GADSS CONOPS Requirement	Comparison of Annex 11 vs GADSS CONOPS Requirements, Notes, Comments, Questions
	<p><i>the declaration of a distress phase, if there is reasonable certainty that this phase will eventuate.</i></p> <p>5.2.3 Further to the notification in 5.2.1, the rescue coordination centre shall, without delay, be furnished with:</p> <p>a) any useful additional information, especially on the development of the state of emergency through subsequent phases; or</p> <p>b) information that the emergency situation no longer exists.</p> <p><i>Note. — The cancellation of action initiated by the rescue coordination centre is the responsibility of that centre.</i></p>		<p>Repository is intended to accessible to the RCC CONOPS 3.4.3 – 3.4.6 and Fig c</p>
<p>5.3 Use of communication facilities</p>	<p>Air traffic services units shall, as necessary, use all available communication facilities to endeavour to establish and maintain communication with an aircraft in a state of emergency, and to request news of the aircraft.</p>		<p>There is a contrast between annex 11 and ADT. Annex is seeking verbal confirmation of the aircraft, ADT is seeking position report of the aircraft – this is not necessarily a conflict; the ATS could have tracking data from ADT and could still be working to establish voice communication to ascertain details and help needed.</p>

STRAWMAN FOR ARINC PROJECT PAPER 680

Annex 11 Section	Annex 11 Requirement	GADSS CONOPS Requirement	Comparison of Annex 11 vs GADSS CONOPS Requirements, Notes, Comments, Questions
<p>5.4 Plotting aircraft in a state of emergency</p>	<p>When a state of emergency is considered to exist, the flight of the aircraft involved shall be plotted on a chart in order to determine the probable future position of the aircraft and its maximum range of action from its last known position. The flights of other aircraft known to be operating in the vicinity of the aircraft involved shall also be plotted in order to determine their probable future positions and maximum endurance</p>		<p>Repository is accessible to the RCC CONOPS 3.4.3 – 3.4.6 and Fig c</p>
<p>5.5 Information to the operator</p>	<p>5.5.1 When an area control or a flight information centre decides that an aircraft is in the uncertainty or the alert phase, it shall, when practicable, advise the operator prior to notifying the rescue coordination centre.</p> <p><i>Note.— If an aircraft is in the distress phase, the rescue coordination centre has to be notified immediately in accordance with 5.2.1.</i></p>	<p>CONOPS 4.3.14 ATS information to the aircraft operator (ICAO Annex 11, 5.5) 4.3.14 When an area control or a flight information centre decides that an aircraft is in the Uncertainty or the Alert phase, it will, when practicable, advise the operator prior to notifying the RCC. On the other hand, if an aircraft is in the distress phase, the RCC is notified immediately. The operator is then notified when practicable and receives the same information as the RCC.</p> <p>CONOPS 3.4 Information sharing and Processes for the Notification of a Distress Condition 3.4.1 When it is identified that an aircraft is experiencing a distress condition, the RCC will be alerted.</p>	<p>Leaves open that ATC may detect distress (MAYDAY) but the aircraft system may not.</p> <p>If its under normal operations but with a mayday the repository will not contain the aircraft info unless a manual or ground trigger is initiated.</p>

STRAWMAN FOR ARINC PROJECT PAPER 680

Annex 11 Section	Annex 11 Requirement	GADSS CONOPS Requirement	Comparison of Annex 11 vs GADSS CONOPS Requirements, Notes, Comments, Questions
		<p>The effectiveness and efficiency of any subsequent RCC and SAR action will rely on timely notification. The alerting process is consistent with the current provisions in ICAO Annex 11, which is:</p> <ul style="list-style-type: none"> ☑ If an ATS unit detects a distress condition they will notify the RCC and the operator; ☑ If the operator detects a distress condition they will notify the ATS unit who will in turn notify the RCC; ☑ If an ELT or ELT-DT is activated the RCC will be notified via the Cospas-Sarsat system; ☑ The RCC may receive notification directly from outside sources. <p>CONOPS 4.3.2 Figure E illustrates the main information links for an emergency requiring the sharing of aircraft tracking information. As a result of triggers the ADT function will be activated and the information forwarded by the ADT provider to the aircraft operator and/or RCC.</p>	
	<p>5.5.2 All information notified to the rescue coordination centre by an area control or flight information centre shall, whenever practicable, also be communicated, without delay, to the operator</p>		<p>These data flows should remain needed even with implementation of ADT systems, RCC and FIC may have more detailed information based on voice comm, other aircraft etc...</p>

STRAWMAN FOR ARINC PROJECT PAPER 680

Annex 11 Section	Annex 11 Requirement	GADSS CONOPS Requirement	Comparison of Annex 11 vs GADSS CONOPS Requirements, Notes, Comments, Questions
5.6 Information to Aircraft operating	5.6 Information to aircraft operating in the vicinity of an aircraft in a state of emergency		N/A

A.1.3 ICAO GADSS Concept of Operations (ConOps)

The ICAO GADSS ConOps requirements that apply to ADT are documented in the following table. The section number refers to the section within the ICAO GADSS ConOps document.

Table 8: GADSS CONOPS Requirements Summary.

Section	Requirement
3.2.1	The Autonomous Distress Tracking (ADT) function is used to identify the location of an aircraft in distress with the aim of establishing, to a reasonable extent, the location of an accident site within a 6 NM radius.
3.2.2	The ADT function uses on board systems to broadcast the 4D position, or distinctive distress signals from which the 4D position can be derived. The position information needs to be transmitted, without the need for flight crew action, at least once every minute when an aircraft is in a distress condition. An aircraft is in a distress condition when it is in a state that, if the aircraft behaviour event is left uncorrected, may result in an accident.
3.2.3	In terms of the autonomy, the ADT function needs to transmit as long as practically possible during the distress condition. "As practically possible" refers to a means to achieve resilience to failures of the aircrafts' electrical power, navigation and communication systems as well as to human factors and unlawful human intervention or tampering.
3.2.4	The operator will need to be notified (directly or indirectly) when an aircraft is in a distress condition. The ADT function will need to include the capability to deliver the distress tracking information to SAR.

STRAWMAN FOR ARINC PROJECT PAPER 680

Section	Requirement
3.2.5	<p>To identify a distress condition, the aircraft state will be analysed in real-time by aircraft systems or ground processes and the use of event detection and triggering criteria logic will initiate the notification of the alert to assist locating the aircraft in distress. Distress tracking is a combination of position reporting at intervals of one minute or less with a notification of distress. The event detection and triggering can be used to identify a distress condition (for a system that is already transmitting position information), or to notify a distress condition and also commence transmitting of position information. Distress tracking manually initiated by the flight crew should also generate a notification.</p>
3.2.6	<p>The triggering criteria may include analysis of unusual altitudes, unusual speeds, potential collision with terrain, total loss of thrust/propulsion on all engines, Mode A squawk codes, etc. The triggers will be defined making sure that the criteria used maximises the probability of detection of an upcoming catastrophic event and minimises the probability of nuisance events.</p>
3.2.7	<p>In the case of an on-board triggered transmission system (distinctive distress signal), initial transmission of position information shall commence immediately or no later than five seconds after the detection of the distress condition.</p> <p><i>Note: The performance specifications for the in-flight event detection and triggering criteria are detailed in EUROCAE ED-237.</i></p>
3.2.8	<p>In case of recovery from the distress condition, distress tracking and any distress signal needs to be de-activated, however, the deactivation can only be done by the activating mechanism.</p>
3.2.9	<p>Functionality may be included that allows the aircraft operator to activate the ADT function, for example, when there is a (risk of) failure of the aircraft tracking systems or there is uncertainty about the status of the aircraft.</p>

STRAWMAN FOR ARINC PROJECT PAPER 680

Section	Requirement
3.2.10	<p>The ADT function approved by the State of the Operator should consider high-level performance criteria such as:</p> <ul style="list-style-type: none">a) Appropriate for the expected duration of flightb) Quality and integrity of data being transmittedc) Robustness of the communication link, including timely receipt of information and recovery after link-loss during unusual attitudesd) Cyber security considerationse) Robustness of the system performing the transmissionf) Global coverage
3.4.1	<p>When it is identified that an aircraft is experiencing a distress condition, the effectiveness and efficiency of any subsequent RCC and SAR action will rely on the timely notification and sharing of relevant and consistent information between the actors involved. The source of the data will depend on which GADSS function identified the distress condition, however, in all cases the information to be shared will include:</p> <ul style="list-style-type: none">• Position (4D) information including:<ul style="list-style-type: none">– Last known position– Flight Track (past position reports)– Planned route as updated by ATC• Distress event trigger or type of emergency (why is the aircraft considered to be in distress)• Flight Plan information<ul style="list-style-type: none">– Field 19• Flight/cargo manifest information<ul style="list-style-type: none">– Dangerous Goods

STRAWMAN FOR ARINC PROJECT PAPER 680

Section	Requirement
3.4.2	<p>The sharing of distress tracking information requires global coverage and a global system approach. Pending the global coverage of System Wide Information Management (SWIM), this information should be made available through a distress tracking repository service as shown in the figure below:</p> <div data-bbox="418 657 1073 1157" style="text-align: center;"> <p>ADT DATA RETENTION LOCATION AND ACCESS</p> <p>The diagram illustrates the ADT data retention and access process. It shows a central 'ADT DATA REPOSITORY (to be defined)' which stores '4D/1 Data'. Data flows from aircraft into this repository. The aircraft are categorized into 'Distress EUROCAE ED-237', 'Potential distress', 'Abnormal situation', and 'Continuous 4D/1 tracking'. A 'Distress' state is highlighted with a red oval. A 'Rescue Coordination Centers (RCCs)' box is shown with an arrow labeled 'ACCESS TO ADT DATA' pointing to the repository. Below the repository, 'SAR assets' are shown with an arrow pointing to them. A note indicates that 'Operator retained information (may be required to be provided in the event of an incident/Accident)' is submitted upon request to the repository. A '~6 NM radius' is indicated around the aircraft. Notes specify that ADT systems may initiate 4D/1 data transmissions prior to distress conditions and that data is retained by the operator for incident/accident investigations.</p> </div>
3.4.3	<p>The distress tracking repository service ideally should be provided through a single infrastructure for the alerting and dissemination of distress beacon information. When necessary (in case of a situation which is distress or is judged to evolve towards distress) operators will submit relevant tracking information to the repository service to ensure timely availability to local RCC('s).</p>

STRAWMAN FOR ARINC PROJECT PAPER 680

Section	Requirement
3.4.4	<p>The point of contact repository service should be provided to assist an operator in contacting an ATSU (and if needed an RCC). The point of contact (PoC) information repository service should allow the position of the aircraft to be correlated to the appropriate ATS units and RCC areas of responsibility. The following minimum information can be returned by submitting a position:</p> <ul style="list-style-type: none"> • The identification and point of contact of the ATS unit and RCC responsible for the area of jurisdiction in which the position fits; • In case the position is near to an ATS unit boundary the neighbouring ATS unit Identification and Point of Contact will also be provided; • In case the position is near to an RCC boundary the neighbouring RCC Identification and Point of Contact will also be provided.
3.4.5	<p>The service needs to be available 24/7 and its content is subject to a maintenance process that ensures that the information is accurate and complete to the maximum extent possible and practical.</p>
4.7	<p>In an Emergency phase, aircraft tracking information needs to be available to all actors.</p>
4.8	<p>In order to identify the nature of the situation and any corrective measures, communications will be established between the relevant ATS unit(s) and the aircraft operator. This will help eliminate any time lag regarding the establishment of the communications themselves and analysis both by the aircraft operator and the ATS unit of action required.</p>
4.8.1	<p>When the ATS unit detects an aircraft in distress it will monitor the situation and communicate, and assist as required. The ATS unit will need to contact the aircraft operator to seek additional information and assist with the emergency phase.</p>
4.8.2	<p>When the aircraft operator detects a distress condition it will contact the ATS unit corresponding with the latest known position of the aircraft. The aircraft operator will provide the ATS unit any additional information deemed relevant including the event that initiated the aircraft operator action. At this point, the ATS unit initiates the appropriate emergency phase and should attempt to establish contact with the aircraft.</p>
4.8.3	<p>When an RCC detects an aircraft in distress it will contact the ATS unit and the aircraft operator.</p>

STRAWMAN FOR ARINC PROJECT PAPER 680

Section	Requirement
4.9	Emergency phases are used as a standardised method in the ATS/SAR system (ATS units and RCCs) to notify the level of concern for the safety of persons or aircraft which may be in danger.
4.10	<p>The figure below illustrates the main information links for an emergency requiring the sharing of aircraft tracking information. As a result of on board triggers the ADT can be activated and the information forwarded by the ADT provider to the aircraft operator and RCC. The ATS unit may make use of additional sources of information and share this with the actors. Other ATS units may also receive aircraft tracking information; for example, when there is a probability that the flight will enter their area of jurisdiction.</p> <pre> graph TD SAR[SAR Services on site] -- "Post Flight Localization e.g. ELT" --> AC[A/C] AC -- "Communication Surveillance" --> SAR AC -- "ADT (e.g. ELT-DT)" --> ADT[ADT Provider e.g. MCC] AC -- "AT" --> AO[Aircraft Operator] ADT -- "ADT" --> AO AO -- "ADT" --> ADT AO -- "A(D)T/PoC" --> GADSS((GADSS Information Management)) ADT -- "A(D)T/PoC" --> GADSS GADSS -- "A(D)T/PoC" --> SAR GADSS -- "A(D)T/PoC" --> AO GADSS -- "A(D)T/PoC" --> ATSU[ATSU] GADSS -- "A(D)T/PoC" --> OATSU[Other ATSU's] GADSS -- "A(D)T/PoC" --> RCC[RCC] GADSS -- "A(D)T/PoC" --> RS((repository service)) RS -- "ATSU/AO ID/PoC RCC ID/PoC" --> GADSS SAR --> RCC RCC -- "Local coordination/information" --> SAR </pre>
4.11	Upon initial notification, an event is classified by the notified RCC or ATS unit as being in one of three emergency phases as specified in Annex 11 Chapter 5: Uncertainty (INCERFA), Alert (ALERFA), or Distress (DETRESFA). The emergency phase may be reclassified as the situation develops. The current emergency phase should be used in all communications about the incident as a means of informing all interested parties of the current level of concern for the safety of persons or craft which may be in need of assistance.

STRAWMAN FOR ARINC PROJECT PAPER 680

Section	Requirement
4.12	<p>Notification by ATS units to RCCs will contain such of the following information as is available in the order listed: <i>(NOTE – the information below is a consolidated list from Annex 11 and the IAMSAR Manual)</i></p> <ul style="list-style-type: none">a) UNCERTAINTY, ALERT or DISTRESS, as appropriate to the phase of the emergency;b) agency and person calling;c) nature of the emergency;d) significant information from the flight plan, including:<ul style="list-style-type: none">• Aircraft call sign and type;• point of departure and departure time;• route of flight;• destination and estimated time of arrival (ETA);• number of persons on board;• endurance;• colour and distinctive markings;• survival equipment carried;• dangerous goods carried;• telephone number of pilot in command;e) unit which made last contact, time and means used;f) aircraft tracking information including last position report and how determined (course, speed, altitude);i) any action taken by reporting office;j) any direction finder equipment available; andj) other pertinent remarks.

STRAWMAN FOR ARINC PROJECT PAPER 680

Section	Requirement
4.13	<p>Information which is not available at the time notification is made to an RCC should be sought by an ATS unit prior to the declaration of a distress phase, if there is reasonable certainty that this phase will eventuate. Further notification to the RCC will, without delay, be furnished by ATS units with:</p> <ul style="list-style-type: none">a) any useful additional information, especially on the development of the state of emergency through subsequent phases; orb) information that the emergency situation no longer exists. <p><i>Note - The cancellation of action initiated by the RCC is the responsibility of that centre.</i></p>
4.20	<p>ATS units and RCCs will normally interact with aircraft operators when there is a need due to an emergency involving one of their aircraft. ATS units/RCCs and aircraft operators may collaborate for emergency planning or exercise purposes.</p>
4.21	<p>When an area control or a flight information centre decides that an aircraft is in the Uncertainty or the Alert phase, it will, when practicable, advise the operator prior to notifying the RCC. On the other hand, if an aircraft is in the distress phase, the RCC is notified immediately. The operator is then notified when practicable and receives the same information as the RCC.</p>
4.22	<p>The emergency status is monitored by the ATS unit and the RCC. The emergency phase may be cancelled as a result of determination of a false alarm or disappearance of the cause of the emergency. Confirmation needs to be received from the crew, ATS unit, aircraft operator and RCC as applicable.</p>

A.2 Regulatory Requirements

Regulatory requirements that apply to ADT are contained in different regional, national, and Civil Aviation Authority (CAA) documents, and are documented within the following sub-sections.

A.2.1 European Union (EU) Regulation

The EU regulation that mandates ADT is:

COMMISSION REGULATION (EU) 2015/2338 of 11 December 2015 amending Regulation (EU) No 965/2012 as regards requirements for flight recorders, underwater locating devices and aircraft tracking systems

STRAWMAN FOR ARINC PROJECT PAPER 680

EU 2015/2338 amends EU No. 965/2012 of 5 October 2012 *laying down technical requirements and administrative procedures related to air operations pursuant to Regulation (EC) No. 216/2008 of the European Parliament and of the Council*

Specifically, EU No. 965/2012, *Annex IV COMMERCIAL AIR TRANSPORT OPERATIONS [PART-CAT] SUBPART A GENERAL REQUIREMENTS* is amended by adding the following new requirement:

CAT.GEN.MPA.210 Location of an aircraft in distress — Aeroplanes

The following aeroplanes shall be equipped with robust and automatic means to accurately determine, following an accident where the aeroplane is severely damaged, the location of the point of end of flight:

- (1) all aeroplanes with an MCTOM of more than 27 000 kg, with an MOPSC of more than 19 and first issued with an individual CofA on or after 1 January 2021; and
- (2) all aeroplanes with an MCTOM of more than 45 500 kg and first issued with an individual CofA on or after 1 January 2021

MCTOM - Maximum Certified Take-Off Mass

Table 9 Analysis/Discussion of EU 2015/2338.

Section	Requirement(s)
Title Page	<p>Definition of function:</p> <p><i>(4) It is necessary to take into consideration the disappearance of flight MH370 on 8 March 2014 and the recommendations made by the multidisciplinary meeting of the ICAO on global tracking of 12 and 13 May 2014. The position of public transport aircraft should be known at all times, even in a remote location, in order to facilitate the location of the aircraft in case of an abnormal behaviour, an emergency or an accident. Whenever possible, the aircraft tracking means should be robust to loss of normal electrical power on board and should not offer any control to disable it during the flight. Therefore, Regulation (EU) No 965/2012 should be amended in order to include additional requirements related to means to track aircraft on a global basis, including over oceans and remote areas.</i></p> <p>Key performance requirement:</p> <ul style="list-style-type: none"> • <i>Whenever possible, the aircraft tracking means should be robust to loss of normal electrical power on board and should not offer any control to disable it during the flight.</i> • <i>on a global basis, including over oceans and remote areas.</i> <p>Discussion / Issues:</p> <ol style="list-style-type: none"> 1. This is bullet point (4) on the title page. 2. There are no loss of power or crew control requirements documented in the actual new regulation <i>CAT.GEN.MPA.210 Location of an aircraft in distress — Aeroplanes</i>. It may be left to the EASA AMC/GM to address loss of power and crew controls/ability to disable requirements as

STRAWMAN FOR ARINC PROJECT PAPER 680

Section	Requirement(s)
	<p>detailed requirements, but we won't know until EASA releases the AMC/GM for CAT.GEN.MPA.210.</p> <p>3. There is no explicit definition of what "global" entails.</p>
<p>Inserted: 'CAT.GEN.MPA.210 Location of an aircraft in distress — Aeroplanes</p>	<p>Definition of function:</p> <p><i>The following aeroplanes shall be equipped with robust and automatic means to accurately determine, following an accident where the aeroplane is severely damaged, the location of the point of end of flight:</i></p> <p>(1) all aeroplanes with an MCTOM of more than 27 000 kg, with an MOPSC of more than 19 and first issued with an individual CofA on or after 1 January 2021; and</p> <p>(2) all aeroplanes with an MCTOM of more than 45 500 kg and first issued with an individual CofA on or after 1 January 2021.'</p> <p>Key performance requirement:</p> <p><i>"The following aeroplanes shall be equipped with robust and automatic means to accurately determine, following an accident where the aeroplane is severely damaged, the location of the point of end of flight"</i></p> <p>Discussion / Issues:</p> <ol style="list-style-type: none"> 1. "robust" isn't defined 2. "automatic" is not defined, but "automatic" could be interpreted to mean that there is no manual action (by the pilot, airline ground operations, or air traffic controller) required in order to determine the location of the point end of the flight. 3. "accurately determine...the location of the point of end of flight" - There are no quantifiable accuracy requirements stated.

STRAWMAN FOR ARINC PROJECT PAPER 680

Section	Requirement(s)
<p>(h) CAT.IDE.A.280 is amended as follows:</p>	<p>Definition of function:</p> <p>EU No. 965/2012 currently states:</p> <p><i>CAT.IDE.A.280 Emergency locator transmitter (ELT)</i></p> <p><i>(a) Aeroplanes with an MOPSC of more than 19 shall be equipped with at least:</i></p> <p><i>(1) two ELTs, one of which shall be automatic, in the case of aeroplanes first issued with an individual CofA after 1 July 2008; or</i></p> <p><i>(2) one automatic ELT or two ELTs of any type, in the case of aeroplanes first issued with an individual CofA on or before 1 July 2008.</i></p> <p><i>(b) Aeroplanes with an MOPSC of 19 or less shall be equipped with at least:</i></p> <p><i>(1) one automatic ELT, in the case of aeroplanes first issued with an individual CofA after 1 July 2008; or</i></p> <p><i>(2) one ELT of any type, in the case of aeroplanes first issued with an individual CofA on or before 1 July 2008.</i></p> <p><i>(c) An ELT of any type shall be capable of transmitting simultaneously on 121,5 MHz and 406 MHz.</i></p> <p>CAT.IDE.A.280 is modified by EU 2015/2338 as follows:</p> <p><i>(i) point (a) is replaced by the following:</i></p> <p><i>‘(a) with an MOPSC of more than 19 shall be equipped with at least:</i></p> <p><i>(1) two ELTs, one of which shall be automatic, or one ELT and one aircraft localisation means meeting the requirement of CAT.GEN.MPA.210, in the case of aeroplanes first issued with an individual CofA after 1 July 2008; or</i></p> <p><i>(2) one automatic ELT or two ELTs of any type or one aircraft localisation means meeting the requirement of CAT.GEN.MPA.210, in the case of aeroplanes first issued with an individual CofA on or before 1 July 2008.’</i></p> <p><i>(ii) point (b) is replaced by the following:</i></p> <p><i>‘(b) Aeroplanes with an MOPSC of 19 or less shall be equipped with at least:</i></p> <p><i>(1) one automatic ELT or one aircraft localisation means meeting the requirement of CAT.GEN.MPA.210, in the case of aeroplanes first issued with an individual CofA after 1 July 2008; or</i></p> <p><i>(2) one ELT of any type or one aircraft localisation means meeting the requirement of CAT.GEN.MPA.210, in the case of aeroplanes first issued with an individual CofA on or before 1 July 2008.’</i></p> <p>Discussion / Issues:</p> <p>For aircraft that meet the distress tracking requirement of CAT.GEN.MPA.210, then an automatic fixed ELT does not need to be installed (or can be removed).</p>

STRAWMAN FOR ARINC PROJECT PAPER 680

A.3 Requirements from Industry Documents, EUROCAE Requirements

Table 10 Analysis/Discussion of ED-237.

Section	Requirement(s)
<p>1.1 - Purpose and Scope</p>	<p>Definition of function: This section provides a general description of the need for this system, justification for Autonomous Distress tracking, general discussion about triggering, background history, and general high level description of ICAO GADSS activates.</p> <p><i>This document defines the minimum specification to be met for criteria which can be used to detect an in-flight aircraft distress event and to trigger the transmission of sufficient information for the purpose of locating an accident site. It only specifies characteristics that are relevant to the logic used for event detection and trigger activation/cancellation</i></p> <p>Discussion / Issues: Need to make clear that this document does not endorse a specific methodology, just the triggering logic of an airborne system only.</p> <p>There is concern that this document has some statements that seem to imply the architecture even though there are other caveats stating the opposite. It is geared toward airborne ADT and does not really address the ground segment of the system – Need harmonization with GADSS CONOPS</p> <p>This document defines triggering of an airborne system without any context of the greater system including the ground. There are requirements of “on or off” distress conditions with 10⁻⁵ restriction of false positives. (Ref.: 3.2.4) There is some concern that manufacturers may create software that may not transmit some data that could have been useful to the ground operation’s analysis of a pre-distress condition.</p>
<p>1.2 - General Requirements</p>	<p>Definition of function: <i>The overall objective of this specification is to make sure that the criteria used to trigger in-flight transmission maximizes the probability of in-flight detection of an upcoming catastrophic event and minimizes the probability of nuisance activation.</i></p> <p><i>This MASPS is intended to define in-flight aircraft distress event detection and triggering criteria that can be used to activate the transmission of information used to locate an aircraft that is experiencing an event that, if left uncorrected, would likely result in an accident. Similar logic also applies to the detection of the return to normal</i></p> <p><i>This MASPS focuses on transport category aeroplanes above 27,000 kg. Therefore, using this MASPS for aircraft in other categories will require evaluation of the applicability of the specifications in this document.</i></p> <p>Discussion / Issues: Does not align with GADSS CONOPS – does not discuss ground triggering and cancellation.</p> <p>Need to harmonize with compliance of all requirements.</p>

STRAWMAN FOR ARINC PROJECT PAPER 680

Section	Requirement(s)
<p>1.2.1 - Background</p> <p>1.2.1.1 - ICAO Activities</p>	<p>Definition of function: Provides a general description of the ICAO GADSS Concept of Operations (ConOps)</p> <p>Discussion / Issues: None</p>
<p>1.2.1.2 – COSPAS SARSAT Activities</p>	<p>Definition of function: General description of COSPAS-SARSAT activities. Discussion about second generation of the MEOSAR system and transponders using GPS/GLONASS and GALILEO satellites.</p> <p>Key performance requirement:</p> <p><i>A number of recommendations resulted from the studies conducted by accident investigation bodies. In particular, it was recommended that EASA and ICAO define the regulatory requirements for a new generation of ELTs that can be triggered in-flight.</i></p> <p><i>In parallel to the development of this document, the ED-62A Minimum Operational Performance Specifications have been improved to detail the specifications for second generation ELTs.</i></p> <p>Discussion / Issues: This section lacks an awareness of alternate Satcom means of transmissions such as Inmarsat and Iridium. It is focused on ELT’s and second generation of MEOSAR related satellites and communication systems.</p>
<p>1.3 - Description of Content</p>	<p>Definition of function: Brief description of the 4 chapters, intent of system and benefit for airlines.</p> <p>Discussion / Issues: Chapters 1.3’s description of section Chapter 1 implies that there is a triggering system description where Chapter 1.1 does not imply that.</p>
<p>1.4 - Operational Applications</p>	<p>Definition of function: General description that the event detection and triggering criteria logic supports SARS and benefits Airlines by providing “almost immediate” distress condition and location</p> <p>Discussion / Issues: None</p>
<p>1.5 - Triggering System</p>	<p>Definition of function: <i>This is an overview of the triggering requirements. Section 3 The triggering system may consist of one or more physical devices. At least one of these devices must host the in-flight aircraft distress event detection and triggering criteria logic described within this MASPS. The triggering system should make the result of the triggering logic available to systems that would transmit information to be used to locate an aircraft that has experienced an accident.</i></p>

STRAWMAN FOR ARINC PROJECT PAPER 680

Section	Requirement(s)
	<p><i>Systems that can potentially transmit flight information include but are not limited to second-generation ELT or other systems (e.g. ACARS, ADS-B...). The system used to transmit the flight information while an aircraft is in a distress condition may have to comply with requirements defined in regulatory documents such as ICAO Annex 6</i></p> <p>Discussion / Issues: Implies that the triggering system may be a separate system from delivery system(s). Need some discussion about the ADT system being able to attempt to communicate via various means available to it on the aircraft and implications for return cancellation of messages should the triggering logic be supplied from the ground (not covered in this document).</p>
<p>1.6 - Verification Procedures</p>	<p>Definition of function: <i>The verification procedures specified in this document are intended to be used as guidance for demonstrating that the in-flight aircraft distress event detection and triggering logic meets the performance requirements. Although specific test procedures are cited, it is recognized that other methods may be used. Alternate procedures may be used if it can be demonstrated that they provide at least equivalent performance.</i></p> <p>Discussion / Issues: Discussed more fully in section 4.</p>
<p>1.7 - Mandating and Recommendation Phrases</p>	<p>Definition of function: Defining SHALL and SHOULD committee</p> <p>Discussion / Issues: None</p>
<p>1.8 - Common Definitions and Abbreviations</p> <p>1.8.1 - Definition of Terms</p>	<p>Definition of function: General description of terms used, no comment needed for most.</p> <p>Discussion / Issues: We noted two below that might lead to discussion</p> <p>Nuisance Trigger - <i>Any trigger that is erroneously generated by the on-board triggering system when there is no potential for an accident.</i></p> <p>Simulation - <i>The use of a laboratory-installed system of avionic components ('test bench') representative of the aircraft in which the recording system is to be certified. The test bench may be controlled by a computer-based system including analogue and discrete inputs, to create specific operating conditions, such as 90° pitch up, or other conditions that cannot be tested in flight or are difficult to test on the aircraft. The test bench should be configured such that the computer or analogue inputs to the system drive the instruments and displays in a way representative of the aircraft. All avionic components installed in the test bench should be either of production standard or representative of the final production configuration.</i></p> <p>Note: there was other discussion about software simulation and the criteria needed to validate trigger logic, discussed in more detail in section 4.</p>

STRAWMAN FOR ARINC PROJECT PAPER 680

Section	Requirement(s)
<p>1.8.2 – Abbreviations</p> <p>1.8.3 - List of Reference Documents</p> <p>1.8.4 – Related Documents</p>	<p>Definition of function: Abbreviations, reference and related docs.</p> <p>Discussion / Issues: None</p>
<p>2.1 – Overall System Introduction</p>	<p>Definition of function:</p> <p><i>This chapter identifies general specifications and design considerations for the in-flight aircraft distress event detection and triggering criteria logic.</i></p> <p><i>The model description below does not imply any particular system architecture employed on board the aircraft or ground-based.</i></p> <p>Discussion / Issues: None</p>
<p>2.2 - Model Description</p>	<p>Definition of function: <i>The components of an in-flight aircraft distress event detection and triggering criteria system can be broken down into individual functional blocks that have unique inputs and outputs. Each functional block is depicted in FIGURE 2-1 and is defined in paragraph 2.2.1. This MASPS deals primarily with the “In-flight distress event detection and triggering criteria” functional block.</i></p> <p>Quantification of requirement: The functional blocks in Fig 2-1 are located on the aircraft.</p> <p>Discussion / Issues: In-flight distress event detection and triggering criteria depends on aircraft data only. While ConOps does not imply system architecture, FIGURE 2-1 does imply an aircraft based architecture. This section appears to provide a functional block diagram, not necessarily a specific architecture.</p> <p>Incompatibility/difference airborne function in ED-237 and ConOps in regards to the detection and notification of a distress state.</p> <p>Proposal:</p> <p>Architecture Component: Distress event detection and triggering logic</p> <p>Phase of Flight: All</p>

STRAWMAN FOR ARINC PROJECT PAPER 680

Section	Requirement(s)
<p>3.1 - Introduction</p>	<p>Definition of function: <i>The purpose of this section is to define the minimum performance of the in-flight aircraft distress event detection and triggering criteria logic. Compliance with this specification is recommended as one means of assuring the logic will perform its intended function satisfactorily under normal operating conditions.</i></p> <p><i>The in-flight aircraft distress event detection and triggering criteria logic shall be designed to process data pertaining to aircraft status and provide output(s) to the transmission system(s) to trigger and/or cancel the transmission of flight information. This specification provides a minimum set of scenarios to be detected by the in-flight event detection and triggering logic.</i></p> <p><i>In order to minimize nuisance triggers and optimize triggering logic, the logic may be inhibited or may be limited in its ability to detect distress events during the following flight phases: take-off, initial climb, final approach, landing and go-around.</i></p> <p><i>Inhibition of the triggering logic shall not cancel an active trigger.</i></p> <p>Key performance requirement:</p> <p>Quantification of requirement: The triggering criteria logic may change based on the flight phase.</p> <p>Discussion / Issues: This is a summarized function to process aircraft status and transmit relevant data, an introduction. Again, the triggering logic is based on aircraft status.</p> <p>Proposal: Recommend to allow non aircraft systems to process aircraft data to determine aircraft status</p> <p>Architecture Component:</p> <p>Phase of Flight: All</p>
<p>3.2 - Triggering Criteria</p>	<p>Definition of function: <i>The triggering criteria should monitor the aircraft state for the occurrence of pre-defined scenarios. A minimum occurrence duration of a particular condition of a scenario (the persistence time) should also be considered as part of the triggering criteria logic. The triggering criteria should include logic to detect if the aircraft returns to "normal" flight to allow automatic cancellation.</i></p> <p><i>The set of triggering criteria should maximize the detection of scenarios, while limiting nuisance triggering. Excessive nuisance triggers have the potential to reduce confidence in the system as well as saturate SAR resources.</i></p> <p>Key performance requirement: Quantification of requirement:</p>

STRAWMAN FOR ARINC PROJECT PAPER 680

Section	Requirement(s)
	<p>Discussion / Issues: The logic should address the temporary scenarios, including persistence time criteria, and cancellation.</p> <p>Proposal:</p> <p>Architecture Component:</p> <p>Phase of Flight: All</p>
<p>3.2.1 - Scenarios</p>	<p>Definition of function: <i>The scenarios listed below were developed based on analyses which included reviews of previous events and represent the minimum set which should be detected by the logic. They are identified by conditions which, if left uncorrected, are likely to result in an accident. Manufacturers may include additional scenarios or combine scenarios, provided that they do not impair the overall efficiency and/or reliability of the triggering logic.</i></p> <p><i>Each condition is defined by parametric data thresholds which may differ depending on the type of aircraft and its mission (as for example military training phase, aerial work, Search And Rescue civil, passenger transport).</i></p> <p>Scenario 1: Unusual attitude. <i>The conditions may include, but are not limited to, excessive values of roll, pitch and yaw and their corresponding rates of change</i></p> <p>Scenario 2: Unusual speed. <i>The conditions may include, but are not limited to, excessive vertical speed, stall condition, low airspeed, over speed or other speed conditions.</i></p> <p>Scenario 3: Collision with terrain. <i>The conditions may include, but are not limited to, high rate of closure to terrain or inappropriate altitude for the current position.</i></p> <p>Scenario 4: Total loss of thrust/propulsion on all engines. <i>The parametric data used to define this condition may be engine performance parameters or other parameters that result from loss of thrust.</i></p> <p>Key performance requirement:</p> <p>Quantification of requirement:</p> <p>Discussion / Issues: Provides examples of scenarios the logic should detect based on previous accidents</p> <p>Need more details about nuisance triggers?</p> <p>Should we assume nuisance trigger automatically ceases when condition ends?</p> <p>Suggests analysis should be conducted for specific aircraft types and conditions that evolve over time.</p> <p>Should address scenario 3: collision with terrain. Relatively easy to locate aircraft that collides with terrain (versus water/ocean). Compatible with GADS functionality?</p> <p>Proposal: Consider other situations for Scenario 3.</p>

STRAWMAN FOR ARINC PROJECT PAPER 680

Section	Requirement(s)
	<p>Architecture Component:</p> <p>Phase of Flight: All</p>
<p>3.2.2 - Persistence Time</p>	<p>Definition of function: <i>The persistence time is the duration for which the condition(s) is true before a triggering signal is generated. The persistence time for each of the criteria should be balanced to trigger a transmission, as soon as practicable, that captures the greatest number of accidents possible while limiting the number of nuisance triggers.</i></p> <p>Key performance requirement:</p> <p>Quantification of requirement:</p> <p>Discussion / Issues: There should be a duration for the criteria before transmitting distress alert. Balance the nuisance rate with the valid trigger of a distress state.</p> <p>Proposal:</p> <p>Architecture Component:</p> <p>Phase of Flight:</p>
<p>3.2.3 - Automatic Cancellation Trigger</p>	<p>Definition of function: <i>A “transmission cancellation notification” will be generated when there are no triggering conditions present and the trigger cancellation criteria have been met. The set of trigger cancellation criteria should maximize the probability to detect that the flight crew have regained control of the aircraft and are maintaining a stable flight regime or the aircraft has landed safely. The notification will be generated for a duration sufficient for the transmitter to receive it, after which the triggering logic returns to its normal detection function.</i></p> <p>Key performance requirement:</p> <p>Quantification of requirement:</p> <p>Discussion / Issues: Adds a triggering cancellation criteria based on flight crew have regained control of the aircraft and are maintaining a stable flight regime. Based on aircraft data (not flight crew). If manually activate distress, then it can be manually cancelled. Implies a persistence time. Note, seems to look at a specific architecture. Can’t send cancellation and alert at the same time.</p> <p>Proposal: Triggering and cancellation shall be distinguishable from each other. Aircraft in condition to trigger, once recovered, then cancel. Distinguish active cancellation. Cancellation positively transmitted.[Revisit]</p>

Commented [ACO23]: This really needs

STRAWMAN FOR ARINC PROJECT PAPER 680

Section	Requirement(s)
	<p>Architecture Component:</p> <p>Phase of Flight: All</p>
<p>3.2.4 - Nuisance Trigger</p>	<p>Definition of function: To minimize nuisance triggers [for distress condition]</p> <p>Key performance requirement:</p> <p>The triggering logic should implement accurate criteria specific to the target aircraft and be verified for correct operation against a database of exemplar flight data.</p> <p>Quantification of requirement:</p> <p><i>Nuisance rate objective of no more than 2 nuisance triggers per 100 000 Flight Hours.</i></p> <p><i>The portion of the overall nuisance rate attributable to the triggering logic and causing a false alert to SAR providers, shall be no more than 1 nuisance trigger per 100 000 Flight Hours.</i></p> <p>Discussion / Issues:</p> <p>The challenge may be to have a common/recognized "a database".</p> <p>Aircraft in distress condition and then transmit, ignores an alert condition. Puts more effort on ground system to process alerts vs. hard distress.</p> <p>Points to inflight detection and transmission. Are all transmissions distress conditions?</p> <p>ELT tracking is distress only. Iridium/Inmarsat based systems are not limited to distress only.</p> <p>Distress indicates imminent danger.</p> <p>ED-237 focuses on specific portion of GATS concept.</p> <p>How to refine the definition of a nuisance trigger? A nuisance trigger does not justify a distress condition.</p> <p>Proposal:</p> <p>Architecture Component:</p> <p>Phase of Flight:</p>

STRAWMAN FOR ARINC PROJECT PAPER 680

Section	Requirement(s)
<p>3.3.1 - Information In The Trigger</p>	<p>Definition of function: The trigger sent to the transmission systems should contain sufficient information to determine whether the logic is requesting the start of a triggered transmission or the transmission of a cancellation signal.</p> <p>Key performance requirement: Shall be able to differentiate between the triggering and cancellation. Clarifies the need for an active transmission of a cancellation message.</p>
<p>4.1 - Introduction: Performance Requirement Verification</p>	<p>Definition of function:</p> <p>Key performance requirement:</p> <p>Quantification of requirement:</p> <p>Discussion / Issues: Introduction to this section.</p> <ul style="list-style-type: none"> • Activation verification based on conditions and trajectories extracted from known accidents, • Non-Activation verification based on conditions and trajectories extracted from known flights that did not result in an accident, • Automatic cancellation verification, <p>Proposal:</p> <p>Architecture Component:</p> <p>Phase of Flight:</p>
<p>4.2 - Performance Verification of Triggering Criteria</p>	<p>Definition of function:</p> <p>Key performance requirement: Verification ensures that all triggering logic and criteria parameters used are adequate, reliable, and robust.</p> <p><i>The following items shall be considered when evaluating the robustness of the triggering and cancellation logic:</i></p> <ul style="list-style-type: none"> • <i>Event detection rate</i> • <i>Nuisance trigger rate</i> • <i>Cancellation cases</i> • <i>Erroneous cancellation cases while in distress</i> <p>Quantification of requirement:</p> <p>Discussion / Issues: Erroneous cancellation cases are not defined anywhere else, how much weight do we want to put on them? Are there quantifiable test cases defined anywhere or implicit (1 per 100,000)</p>

STRAWMAN FOR ARINC PROJECT PAPER 680

Section	Requirement(s)
	<p>How can we prove this, are there test databases? This is the negative false report versus false positive.</p> <p>Very rare event with a 10^{-5} is a very high standard. It was noted by OEMs that auto-pilot software ex.: CAT3 auto-land, and end of runway detection etc. has the same strict requirements. Alternate views expressed were - those are very predictable set of circumstances, and this distress detection trigger logic requires detection of rare and non-normal conditions.</p> <p>Proposal:</p> <p>Architecture Component:</p> <p>Phase of Flight:</p>
<p>4.2.1 -Verification of Event Detection Rate</p>	<p>Definition of function:</p> <p>Key performance requirement:</p> <p>Identifies an accident database is provided (in appendix 1), which is a minimum set for testing. All test scenarios may not be complete for validation. See below</p> <p>Quantification of requirement:</p> <p>Specifies that must have 100% compliance when testing against this database except when justified.</p> <p><i>Note: Event detection rate verification using only the datasets provided by the investigation agencies is incomplete. If those are the only accident datasets used, additional analytical verification is required to ensure that all scenarios defined in Chapter 3 are captured.</i></p> <p>Discussion / Issues:</p> <p>100% compliance against testing using the known database, this is a very broad statement.</p> <p>Not all parameters for testing may not be available within the provided databases. This cannot be the only means of verification.</p> <p>We are missing definition of the criteria for justification of not meeting the 100% testing requirement.</p> <p>Proposal:</p> <p>If this database is admittedly insufficient – then we recommend that the committee identify additional databases or methodologies to be able to test against all the possible scenarios in chapter 3.</p> <p>Architecture Component:</p> <p>Phase of Flight:</p> <p>All phases – however chapter 3.1 gives a bit of leeway for some phases flight, i.e. takeoff and approaches</p>

STRAWMAN FOR ARINC PROJECT PAPER 680

Section	Requirement(s)
<p>4.2.2 - Verification of Nuisance Trigger Rate</p>	<p>Definition of function:</p> <p><i>One means to verify the nuisance trigger rate (see 3.2.4 Nuisance Trigger) of the logic is to run the logic on a database of operationally representative flight data and to evaluate the resulting nuisance rate. The database should contain a sufficient number of flights to adequately assess the resulting nuisance rate against the objective.</i></p> <p><i>When building the database, it is recommended to use flights from similar aircraft types. It is recognized that operational data may not be available, and other aircraft types may be used if justified.</i></p> <p><i>The applicant, in coordination with the regulatory authorities, may determine that testing the complete set of triggers against such a database is impractical. In these cases, the regulatory authorities may accept an analytical approach to verifying the nuisance trigger rate, based on simulated data or combining the results of testing subsets of the logic.</i></p> <p>Key performance requirement:</p> <p>The database has to be valid for the aircraft type being certified. Since getting enough data about an aircraft may be difficult, then other aircraft type databases types may be used if justified.</p> <p>Quantification of requirement:</p> <p>Discussion / Issues:</p> <p>The specification applies to all aircraft types. Need large datasets for all aircraft types.</p> <p>Trigger rates on the order of 1/100K - probably need a couple million hours of data to have confidence that we can meet 1 in 100k (10⁻⁵) Might be beyond the capabilities and maturity of the industry to be able to provide complete datasets for testing</p> <p>This is the inverse of 4.2.1</p> <p>How do we justify similar aircraft type's datasets for a target aircraft type being certified? Need definition of justification.</p> <p>Higher propensity of nuisance alerts in some phases. Identify window of allowable events ex: Takeoff and Landings - transiting between these phases</p>

STRAWMAN FOR ARINC PROJECT PAPER 680

Section	Requirement(s)
	<p>higher likelihood of false positives. Look at those areas more closely during testing</p> <p>The definition varies with aircraft type and mission type (and approach and performance specs.) Section 3 does call out different mission type – we can think of examples of firefighting aircraft swooping and dropping extinguisher payloads, versus normal civilian transport</p> <p>How do we define and produce a common analytical approach or other means of testing that we can all use to validate the system performance, in addition to the given limited test databases?</p> <p>Reference Section 1.8.1 definition of terms – SIMULATION. Need a common criteria for simulations – example: trigger input criteria. We feel that the nuisance trigger definition is inadequate.</p> <p>Proposal:</p> <p>Architecture Component:</p> <p>Phase of Flight:</p>
<p>4.2.3 - Verification of Cancellation Cases and Erroneous Cancellations</p>	<p>Definition of function:</p> <p><i>The verification of the cancellation logic should be performed by analysis to demonstrate that it sufficiently detects the return to normal flight following an event and does not erroneously cancel any trigger before a stable flight regime is maintained.</i></p> <p><i>Appendix 1 incidents and accidents database may be used to support the analysis.</i></p> <p>Key performance requirement:</p> <p>Quantification of requirement:</p> <p>Discussion / Issues: Triggers are extremely rare events – if aircraft autonomous system stop sending signal, even if A/C returns to normal flight , the ground and non-autonomous components of the system will probably be contacting the aircraft / verifying the situation – so trying to test that we don't have false cancellations is very, very rare.</p> <p>So rare almost not applicable?</p> <p>Proposal:</p> <p>Architecture Component:</p> <p>Phase of Flight:</p>

STRAWMAN FOR ARINC PROJECT PAPER 680

Section	Requirement(s)
Appendix 1 - Database Info List of accidents and incidents table and List of Database Parameters table	Key performance requirement: None – INFO only Defines a list anonymized flights within aircraft accidents / incidents database with flight phase and a description of the key scenario. There are 46 Accidents and 24 Incident reported flights.
Appendix 2 - BEA commitment letter	Key performance requirement: None – info only – BEA commitment letter to provide accident/incident database.

Appendix B ADT Architectural Framework to Requirements Mapping

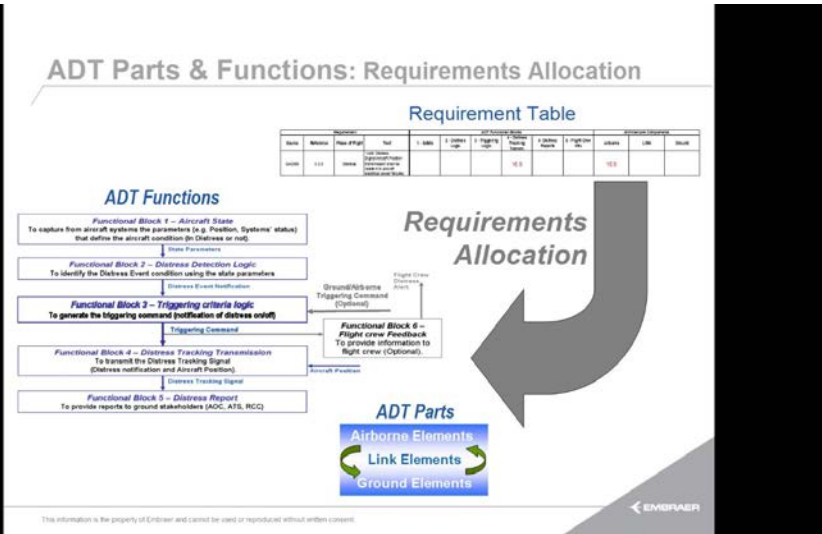

Figure 46 Study Requirements Mapped to Study Architecture Framework

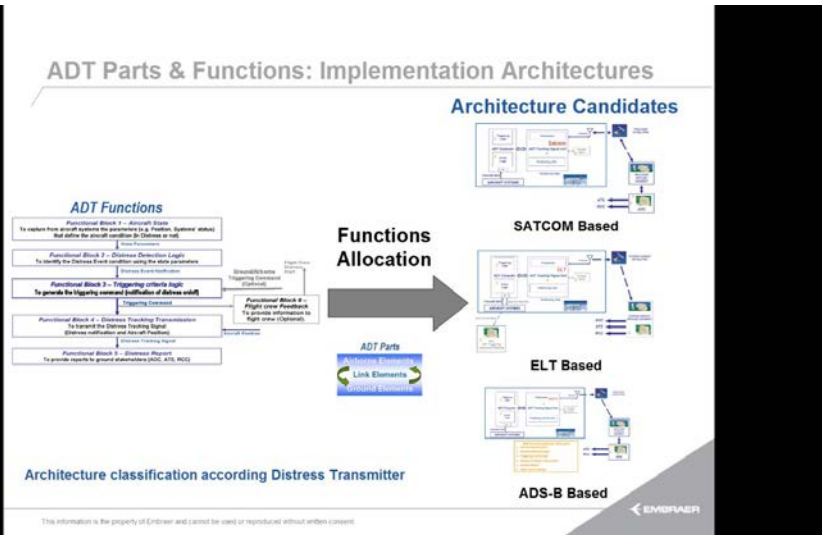

Figure 47 Study Architecture Framework Functions Mapped to Implementation Architectures

STRAWMAN FOR ARINC PROJECT PAPER 680

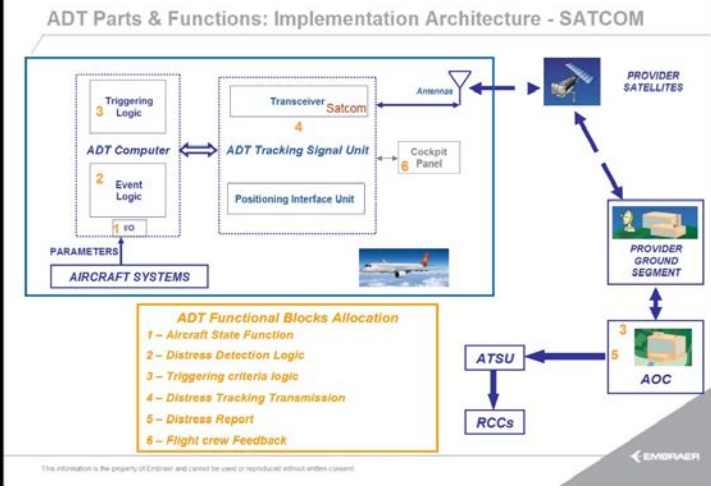

Figure 48 Study Architecture Framework Applied to SATCOM System

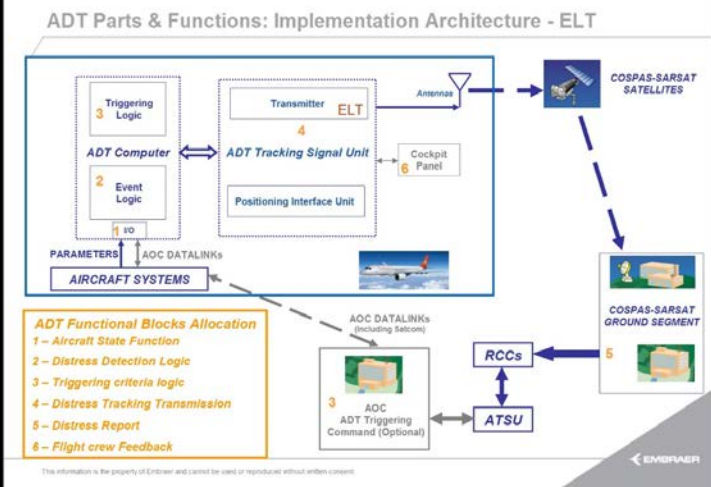

Figure 49 Study Architecture Framework Applied to ELT-DT Based System

STRAWMAN FOR ARINC PROJECT PAPER 680

ADT Parts & Functions: Implementation Architecture – Ground Processing

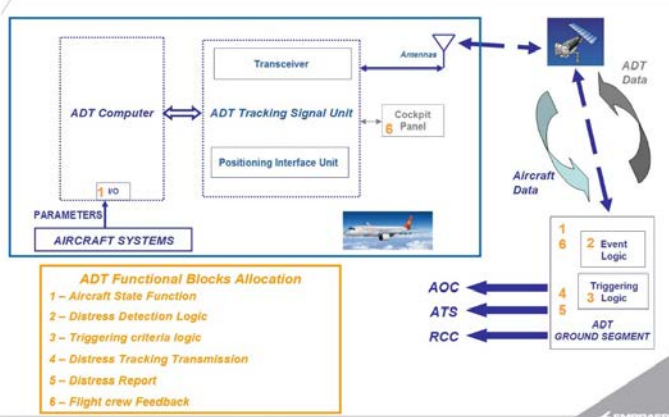

Figure 50 Study Architecture Framework Applied to Ground Processing Functions